

TECHNICAL MANUAL
OPERATOR'S, UNIT, AND DIRECT SUPPORT
MAINTENANCE MANUAL
(INCLUDING REPAIR PARTS & SPECIAL TOOLS LIST)
FOR
CONTAINERIZED KITCHEN (WITH TRAILER)
NSN 7360-01-473-3408

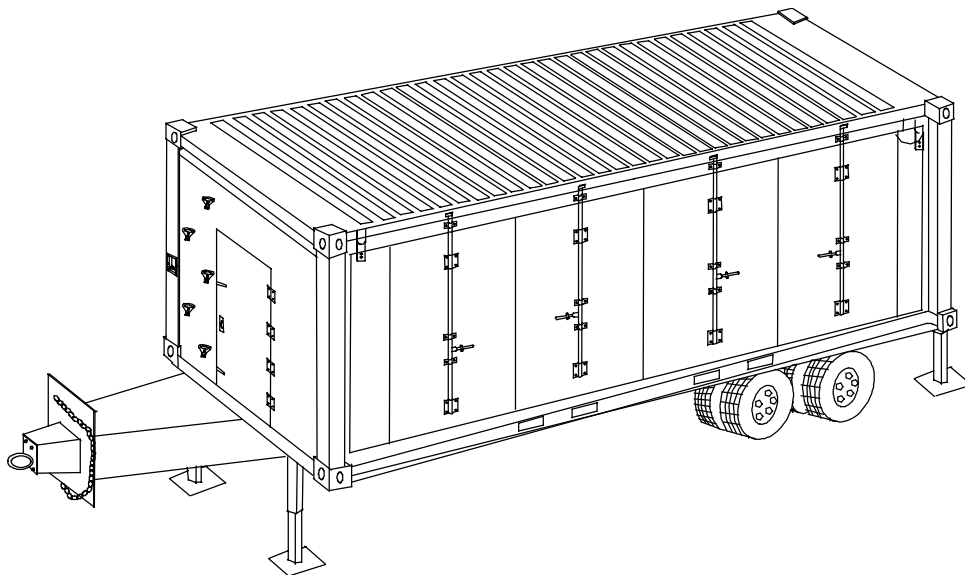

DISTRIBUTION STATEMENT A - Approved for public release; distribution is unlimited.

WARNING SUMMARY

This warning summary contains general safety warnings and hazardous materials warnings that must be understood and applied during operation and maintenance of this equipment. Failure to observe these precautions could result in serious injury or death to personnel.

WARNING

SHOCK HAZARD

HIGH VOLTAGE is used in the operation of the Containerized Kitchen (with Trailer) [CK]. DEATH ON CONTACT may result if personnel fail to observe safety precautions.

DC voltage is present at the generator set electrical components even when it is shut down. Avoid grounding yourself when in contact with electrical components.

Lethal voltage is present when the MBU is connected to a power source. Serious injury or death by electrocution may occur if any energized component is touched.

Do not attempt to connect an energized cable to the Power Entrance Panel.

The CK MUST be properly grounded to ensure personnel safety and proper operation of the appliances and other electrical equipment. DO NOT energize the CK unless it is properly grounded.

Never work on electrical equipment unless there is at least one other person nearby who is familiar with the operation and hazards of the equipment. That person should also be competent in giving first aid. Ask maintenance personnel about extremely hazardous areas of the CK before doing any maintenance. For first aid, refer to FM 21-11.

Whenever possible, remove all power to the CK before performing any maintenance.

WARNING

NOISE HAZARD

With its access door open, the noise level of the generator set when operating could cause hearing damage. Hearing protection MUST be worn when working near the generator set while it is running and its access door is open.

WARNING

TWO PERSON LIFT

An MBU weighs approximately 58 lbs (26.3 kg) fully fueled. Two persons must carry the MBU when fully fueled, lifting with legs, not back, to prevent injury.

WARNING

THREE PERSON LIFT

The bags of arch frame components weigh approximately 130 lbs (59 kg) each, and the packed light storage box weighs approximately 100 lbs (45.4 kg). Three persons must carry these items, lifting with legs, not back, to prevent injury.

WARNING

INHALATION HAZARD

Generator exhaust contains deadly gases. DO NOT operate the generator in an enclosed area unless exhaust discharge is vented outside. Severe personal injury or death could occur due to carbon monoxide poisoning.

During operation, the MBUs produce carbon monoxide, a colorless, odorless, and tasteless gas. Prolonged inhalation of carbon monoxide will cause symptoms of drowsiness, headache, dizziness, and loss of muscular control. When using the MBUs, ensure that the operating space is well ventilated.

In the event of fluorescent lamp breakage, care must be taken in removing broken glass fragments and phosphorous dust that may be dispersed from the fixture. Inhaling phosphorous dust can cause personal injury.

WARNING

FIRE HAZARD

The fuel used in the generator is highly flammable. DO NOT smoke or use open flame when performing maintenance. Fire and explosion can occur, resulting in severe personal injury or death.

DO NOT attempt to connect a fuel line to an MBU in the vicinity of any open flame. Ensure that fuel connections are made properly to avoid fuel spillage. Prevent a possible fire hazard by having rags on hand to absorb any spillage.

WARNING

HOT SURFACES

Let the MBU cool down after operation before moving it or performing any maintenance. This will prevent burn injuries.

After generator operation, ensure that the generator exhaust pipe has cooled down before attempting to disassemble the elbow pipe.

Ensure that all CK components have completely cooled before initiating packout or performing maintenance.

WARNING

HEAVY OBJECT

Read and understand all instructions in this manual before installing or operating the jacks. Personal injury or property damage can occur if the jacks are improperly installed or operated.

NEVER allow anyone or any part of your body to be under any portion of the jacks or the CK container.

The corner and screw jacks are designed for use only with the CK. DO NOT use them to support or level any other container.

The orange safety straps MUST be in place before unlocking the cam-locks on the side wings.

When raising or lowering the wings, one member of the crew must act as a spotter to ensure that all personnel stay clear.

WARNING

DO NOT USE GASOLINE

Gasoline should **NOT** be used with the MBU under any circumstance. **Only JP-8 or an approved alternate diesel fuel may be used.** Using gasoline in the MBU will create a fire danger and potential for explosion.

**Operator's Unit And Direct Support
Maintenance Manual
(Including Repair Parts & Special Tools List)
For
Containerized Kitchen (With Trailer)
NSN 7360-01-473-3408**

DISTRIBUTION STATEMENT A: - Approved for public release; distribution is unlimited.

TM 10-7360-226-13&P, 01 Aug 2001, is updated as follows:

1. File this sheet in front of the manual for reference.
2. This change implements Army Maintenance Transformation and changes the Maintenance Allocation Chart (MAC) to support Field and Sustainment Maintenance.
3. New or updated text is indicated by a vertical bar in the outer margin of the page.
4. Added illustrations are indicated by a vertical bar adjacent to the figure number. Changed illustrations are indicated by a miniature pointing hand adjacent to the updated area and a vertical bar adjacent to the figure number.
5. Remove old pages and insert new pages as indicated below:

Remove Pages

A/(B blank)
DA 2028 Front/Back
DA 2028 Front/Back

Insert Pages

A/(B Blank)
DA 2028 Front/Back
DA 2028 Front/Back
DA 2028 Front/Back

6. Replace the following work packages with their revised version:

Work Package Number

WP 0032 00

ARMY TM 10-7360-226-13&P

Change 3

By Order of the Secretary of the Army:

PETER J. SCHOOMAKER
General, United States Army
Chief of Staff

Official:

SANDRA R. RILEY
*Administrative Assistant to the
Secretary of the Army*
0516413

Distribution: To be distributed in accordance with initial distribution number (IDN) 256683 requirements for TM 10-7360-226-13&P.

TM 10-7360-226-13&P

CHANGE
NO. 2

HEADQUARTERS, DEPARTMENT OF THE ARMY
WASHINGTON, DC, 31 AUGUST 2004

TECHNICAL MANUAL

OPERATOR'S, UNIT, AND DIRECT SUPPORT
MAINTENANCE MANUAL, INCLUDING REPAIR PARTS AND SPECIAL TOOLS LIST
FOR
CONTAINERIZED KITCHEN (WITH TRAILER)

NSN: 7360-01-473-3408

DISTRIBUTION STATEMENT A: - Approved for public release; distribution is unlimited.

TM 10-7360-226-13&P, 01 August 2001, is updated as follows:

1. File this sheet in front of the manual for reference.
2. This change is a result of winch replacement procedures, and corrected National Stock Numbers (NSN)s and/or CAGEC codes and part numbers.
3. New or updated change information is indicated by a vertical bar in the outer margin of the page.
4. Remove old pages and insert new pages as indicated below:

Remove Pages

A/B Blank
i/iv
Chapter 3 Blank

Insert Pages

A/B Blank
i/iv Blank
Chapter 3 Blank

5. Replace the following work packages with their revised version:

<u>Work Package Number</u>	<u>Work Package Number</u>	<u>Work Package Number</u>	<u>Work Package Number</u>
WP 0001 00	WP 0032 00	WP 0039 00	WP 0048 00
WP 0002 00	WP 0033 00	WP 0040 00	WP 0049 00
WP 0006 00	WP 0034 00	WP 0041 00	WP 0051 00
WP 0017 00	WP 0035 00	WP 0043 00	
WP 0018 00	WP 0036 00	WP 0044 00	
WP 0024 00	WP 0037 00	WP 0047 00	

TM 10-7360-226-13&P
C2

By Order of the Secretary of the Army:

PETER J. SCHOOMAKER
General, United States Army
Chief of Staff

Official:

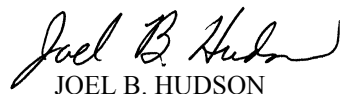

JOEL B. HUDSON
*Administrative Assistant to the
Secretary of the Army*
0423602

Distribution:

To be distributed in accordance with initial distribution number (IDN) 256683 requirements for TM 10-7360-226-13&P.

TM 10-7360-226-13&P

CHANGE
NO. 1

HEADQUARTERS, DEPARTMENT OF THE ARMY
WASHINGTON, DC, 30 APRIL 2002

TECHNICAL MANUAL

OPERATOR'S, UNIT, AND DIRECT SUPPORT
MAINTENANCE MANUAL, INCLUDING REPAIR PARTS AND SPECIAL TOOLS LIST
FOR
CONTAINERIZED KITCHEN (WITH TRAILER)

NSN: 7360-01-473-3408

DISTRIBUTION STATEMENT A: - Approved for public release; distribution is unlimited.

TM 10-7360-226-13&P, 01 August 2001, is updated as follows:

1. File this sheet in front of the manual for reference.
2. This change is a result of oven, pan rack, winch replacement procedures, and corrected National Stock Numbers (NSN)s and/or CAGEC codes and part numbers.
3. New or updated change information is indicated by a vertical bar in the outer margin of the page.
4. Remove old pages and insert new pages as indicated below:

Remove Pages

A/B Blank
I/iv
Index 1-4

Insert Pages

A/B Blank
i/iv
Index 1-4

5. Replace the following work packages with their revised version:

<u>Work Package Number</u>	<u>Work Package Number</u>	<u>Work Package Number</u>	<u>Work Package Number</u>
WP 0002 00	WP 0016 00	WP 0034 00	WP 0048 00
WP 0003 00	WP 0017 00	WP 0036 00	WP 0049 00
WP 0005 00	WP 0020 00	WP 0037 00	WP 0050 00
WP 0006 00	WP 0026 00	WP 0039 00	WP 0051 00
WP 0009 00	WP 0028 00	WP 0044 00	WP 0054 00
WP 0014 00	WP 0032 00	WP 0047 00	

TM 10-7360-226-13&P
C1

By Order of the Secretary of the Army:

Official:

JOEL B. HUDSON
*Administrative Assistant to the
Secretary of the Army*
0209503

ERIC K. SHINSEKI
*General, United States Army
Chief of Staff*

DISTRIBUTION:

To be distributed in accordance with initial distribution IDN 256683, requirements for
TM 10-7360-226-13&P.

INSERT LATEST CHANGED PAGES/WORK PACKAGES. DESTROY SUPERSEDED DATA.

LIST OF EFFECTIVE PAGES/WORK PACKAGES

NOTE: The portion of text affected by the update is indicated by a vertical line in the outer margins of the page. Updates to illustrations are indicated by miniature pointing hands or vertical lines in the outer margins of the page in the area of the illustration changed. Zero in the "Change No." column indicates an original page or work package.

Dates of issue for original manual and changed pages / work packages are:

Original 1 August 2001
 Change 1 30 April 2002
 Change 2 31 August 2004
 Change 3 31 July 2005

TOTAL NUMBER OF PAGES FOR FRONT AND REAR MATTER IS 30 AND TOTAL NUMBER OF WORK PACKAGES IS 55, CONSISTING OF THE FOLLOWING:

Page/WP No.	Change No.	Page/WP No.	Change No.
Front Cover	0	WP 0026 00 (6 pgs)	1
a-c	0	Chp 5 title page	0
d blank	0	WP 0027 00 (2 pgs)	0
i-iv	2	WP 0028 00 (2 pgs)	1
v/(vi blank)	0	WP 0029 00 (2 pgs)	0
Chp 1 title page	0	WP 0030 00 (2 pgs)	0
WP 0001 00 (4 pgs)	2	Chp 6 title page	0
WP 0002 00 (14 pgs)	2	WP 0031 00 (2 pgs)	0
WP 0003 00 (3 pgs)	1	WP 0032 00 (10 pgs)	3
WP 0004 00 (2 pgs)	0	WP 0033 00 (9 pgs)	2
Chp 2 title page	0	WP 0034 00 (7 pgs)	2
WP 00005 00 (12 pgs)	1	WP 0035 00 (13 pgs)	2
WP 00006 00 (36 pgs)	2	WP 0036 00 (6 pgs)	2
WP 0007 00 (4 pgs)	0	WP 0037 00 (10 pgs)	2
Chp 3 title page	2	WP 0038 00 (4 pgs)	0
WP 0008 00 (2 pgs)	0	WP 0039 00 (4 pgs)	2
WP 0009 00 (2 pgs)	0	WP 0040 00 (6 pgs)	2
WP 0010 00 (4 pgs)	0	WP 0041 00 (4 pgs)	2
WP 0011 00 (2 pgs)	0	WP 0042 00 (4 pgs)	0
WP 012 00 (2 pgs)	0	WP 0043 00 (4 pgs)	2
WP 0013 00 (2 pgs)	0	WP 0044 00 (15 pgs)	2
WP 0014 00 (2 pgs)	1	WP 0045 00 (2 pgs)	0
Chp 4 title page	0	WP 0046 00 (2 pgs)	0
WP 0015 00 (2 pgs)	0	WP 0047 00 (2 pgs)	2
WP 0016 00 (10 pgs)	1	WP 0048 00 (4 pgs)	2
WP 0017 00 (14 pgs)	2	WP 0049 00 (16 pgs)	2
WP 0018 00 (8 pgs)	2	WP 0050 00 (2 pgs)	1
WP 0019 00 (4 pgs)	0	WP 0051 00 (2 pgs)	2
WP 0020 00 (4 pgs)	1	WP 0052 00 (2 pgs)	0
WP 0021 00 (4 pgs)	0	WP 0053 00 (2 pgs)	0
WP 0022 00 (4 pgs)	0	WP 0054 00 (10 pgs)	1
WP 0023 00 (2 pgs)	0	WP 0055 00 (4 pgs)	0
WP 0024 00 (4 pgs)	2	INDEX 1 – INDEX 4	1
WP 0025 00 (2 pgs)	0	Back Cover	0

TECHNICAL MANUAL

**OPERATOR'S, UNIT, AND DIRECT SUPPORT
MAINTENANCE MANUAL
(INCLUDING REPAIR PARTS & SPECIAL TOOLS LIST)
FOR
CONTAINERIZED KITCHEN (WITH TRAILER)
NSN 7360-01-473-3408**

REPORTING ERRORS AND RECOMMENDING IMPROVEMENTS

You can help improve this manual. If you find any mistakes or if you know of a way to improve the procedures, please let us know. Mail your letter, DA Form 2028 (Recommended Changes to Publications and Blank Forms), or DA form 2028-2, located in the back of this manual directly to: Commander, U.S. Army Tank-automotive & Armament Command, ATTN: AMSTA-LC-CECT, Kansas St., Natick, MA 01760. You may also submit your recommended changes by E-mail directly to amssbriml@natick.army.mil. A reply will be furnished directly to you. Instructions for sending an electronic 2028 may be found at the back of this manual immediately preceding the hard copy 2028.

DISTRIBUTION STATEMENT A - Approved for public release; distribution is unlimited.

TABLE OF CONTENTS

WP Sequence No.

WARNING SUMMARY

HOW TO USE THIS MANUAL

CHAPTER 1 – INTRODUCTORY INFORMATION WITH THEORY OF OPERATION

General Information	0001 00
Equipment Description and Data	0002 00
Theory of Operation	0003 00
Support Data for Repair Parts, Special Tools, TMDE, and Support Equipment	0004 00

TABLE OF CONTENTS - Continued

CHAPTER 2 – OPERATOR INSTRUCTIONS

Description of Operator Controls and Indicators	0005 00
Operation Under Usual Conditions	0006 00
Operation Under Unusual Conditions	0007 00

CHAPTER 3 – TROUBLESHOOTING PROCEDURES

Introduction	0008 00
Malfunction/Symptom Index.....	0009 00
Troubleshooting Procedures – Electrical System	0010 00
Troubleshooting Procedures – Modern Burner Unit (MBU)	0011 00
Troubleshooting Procedures – Environmental Control Unit (ECU)	0012 00
Troubleshooting Procedures – Hand Sink Assembly.....	0013 00
Troubleshooting Procedures – Kitchen Appliances	0014 00

CHAPTER 4 – OPERATOR/UNIT MAINTENANCE PROCEDURES

Service Upon Receipt	0015 00
Preventive Maintenance Checks and Services (PMCS)	0016 00
Shelter Unit Maintenance Procedures	0017 00
Mechanical Room Unit Maintenance Procedures	0018 00
Cook Center Unit Maintenance Procedures.....	0019 00
Oven Assembly Unit Maintenance Procedures.....	0020 00
Mobile Warming Cabinet Unit Maintenance Procedures	0021 00
Refrigerator Unit Maintenance Procedures.....	0022 00
Tray Pack Heater Unit Maintenance Procedures.....	0023 00
Hand Sink Assembly Unit Maintenance Procedures.....	0024 00
Mobile Storage Cabinet Unit Maintenance Procedures	0025 00
Electrical System Unit Maintenance Procedures	0026 00

CHAPTER 5 – DIRECT SUPPORT MAINTENANCE PROCEDURES

Cook Center	0027 00
Oven Assembly	0028 00
Tray Pack Heater	0029 00
Shelter Assembly	0030 00

**CONTAINERIZED KITCHEN (WITH TRAILER)
THEORY OF OPERATION**

TABLE OF CONTENTS – Continued

CHAPTER 6 – SUPPORTING INFORMATION

References.....	0031 00
Maintenance Allocation Chart (MAC).....	0032 00
Introduction to Repair Parts & Special Tools List.....	0033 00
Group 01 Shelter Repair Parts.....	0034 00
Group 02 Mechanical Room Repair Parts	0035 00
Group 03 Cook Center Repair Parts	0036 00
Group 05 Oven Assembly Repair Parts	0037 00
Group 06 Mobile Warming Cabinet Repair Parts.....	0038 00
Group 07 Refrigerator Repair Parts	0039 00
Group 08 Tray Pack Heater Repair Parts	0040 00
Group 09 Hand Sink Assembly Repair Parts	0041 00
Group 10 Mobile Storage Cabinet Repair Parts.....	0042 00
Group 11 Prep/Serving Table Repair Parts	0043 00
Group 12 Electrical System Repair Parts.....	0044 00
Group 13 Bulk Material Repair Parts	0045 00
Special Tools List.....	0046 00
National Stock Number Index	0047 00
Part Number Index.....	0048 00
Components of End Item (COEI) and Basic Issue Items (BII) Lists.....	0049 00
Additional Authorization List (AAL).....	0050 00
Expendable and Durable Items List	0051 00
Tool Identification List	0052 00
Mandatory Replacement Parts.....	0053 00
Wiring Diagrams.....	0054 00
Appendix A – Trailer Operations	0055 00
Index	Index-1

HOW TO USE THIS MANUAL

This manual contains general information, operating instructions, Preventive Maintenance Checks and Services (PMCS), and maintenance/repair instructions for the Containerized Kitchen (with Trailer) [CK].

Front matter consists of front cover, warning summary, title block, table of contents, and "how to use this manual" pages. Chapter 1 provides introductory information on the CK and its associated equipment as well as theory of operation. Chapter 2 provides instructions for operating under usual and unusual conditions. Chapter 3 contains Operator troubleshooting procedures authorized at the unit level. Chapter 4 contains Preventive Maintenance Checks and Services (PMCS) and Operator/Crew maintenance instructions. Maintenance procedures authorized at the Direct Support level are found in Chapter 5. Chapter 6 contains the Maintenance Allocation Chart (MAC); it also includes the Repair Parts & Special Tools List (RPSTL) that identifies parts or tools unique to the operation and maintenance of the CK. Rear matter consists of the alphabetical index, DA Form 2028, authentication page, and back cover.

Manual Organization and Page Numbering

This manual is divided into six major chapters that detail the topics mentioned above. Within each chapter are work packages covering a wide range of topics. Each work package is numbered sequentially starting at page 1, and has its own page numbering scheme that is independent of the page numbering used by other work packages. Each page of a work package has a page number of the form "XXXX YY-ZZ", where "XXXX YY" is the work package number (e.g. 0010 00 is work package 10) and "ZZ" represents the number of the page within that work package. A page number such as "0010 00-1/2 Blank" means that page 1 of that work package contains information but page 2 has been intentionally left blank.

Finding Information

The Table of Contents permits the reader to quickly find information in the manual. The reader should start here first when looking for a specific topic. The Table of Contents lists the topics contained within each chapter and the work package sequence number where it can be found. The index, located at the back of the manual, lists topics in alphabetical order and identifies the work packages where the information is located.

TM 10-7360-226-13&P

CHAPTER 1

**INTRODUCTORY INFORMATION
WITH THEORY OF OPERATION
FOR
CONTAINERIZED KITCHEN (WITH TRAILER) [CK]**

CONTAINERIZED KITCHEN (WITH TRAILER)
GENERAL INFORMATION

SCOPE**Equipment Covered**

This technical manual contains instructions for the operation, preventive maintenance, Unit and Direct Support corrective maintenance for the Containerized Kitchen (with Trailer) [CK] and its associated equipment.

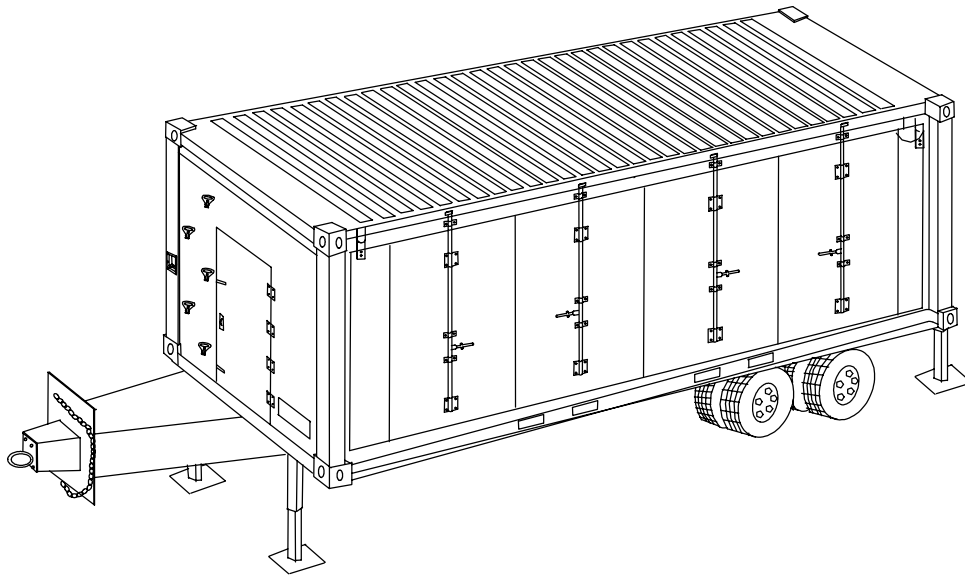

Figure 1. Containerized Kitchen (with Trailer) [CK].

Type of Manual

Operator's, Unit and Direct Support Operation and Maintenance Manual, including Repair Parts & Special Tools List.

Equipment Name and Model Number

Containerized Kitchen (with Trailer), NSN 7360-01-473-3408, Part No. 47010001.

**CONTAINERIZED KITCHEN (WITH TRAILER)
GENERAL INFORMATION**

Purpose of Equipment

The CK is a mobile, rapidly deployable kitchen that is capable of preparing and serving up to 650 Army field menu meals (A-Ration, Heat and Serve Ration or any combination) up to three times per day. The CK enables cooks to prepare a meal (A-Ration) in less than three hours.

MAINTENANCE FORMS, RECORDS AND REPORTS

Department of the Army forms and procedures used for equipment maintenance will be those prescribed by DA PAM 738-750.

EQUIPMENT IMPROVEMENT REPORT RECOMMENDATIONS (EIR)

If your CK needs improvement, let us know. Send us an EIR. You, the user, are the only one who can tell us what you don't like about your equipment. Let us know why you don't like the design or performance. Put it on an SF 368, Product Quality Deficiency Report. Mail it to: Commander, U.S. Army Soldier and Biological Chemical Command; ATTN: AMSSB-RIM-E(N), Kansas Street, Natick, MA 01760-5052. We will send you a reply.

CORROSION PREVENTION AND CONTROL (CPC)

Corrosion prevention and control (CPC) of Army materiel is a continuing concern. It is important that any corrosion problem with the CK be reported so that the problem can be corrected and improvements can be made to prevent the problem in future items.

While corrosion is typically associated with rusting of metals, it can also include deterioration of other materials, such as rubber or plastic. Unusual cracking, softening, swelling or breaking of these materials may be a corrosion problem.

If a corrosion problem is identified, it can be reported using SF-368, Product Quality Deficiency Report. Use of key words such as "corrosion", "rust", "deterioration" or "cracking" will ensure that the information is identified as a CPC problem. The form should be submitted to the address specified in DA PAM 738-750, Functional Users Manual for the Army Maintenance Management System (TAMMS).

DESTRUCTION OF ARMY MATERIEL TO PREVENT ENEMY USE

For procedures to destroy the CK to prevent its use by the enemy refer to TM 750-244-3.

PREPARATION FOR STORAGE AND SHIPMENT

The CK is stored and shipped only in its fully packed-out configuration. Refer to WP 0006 00 for packout procedures.

WARRANTY INFORMATION

SFA Inc., Frederick Manufacturing Division warrants the CK system to be free from defects in materials and workmanship for a period of one year from acceptance. The CK contains a number of items covered by the original equipment manufacturer's warranty.

**CONTAINERIZED KITCHEN (WITH TRAILER)
GENERAL INFORMATION**

These individual warranties vary in terms and conditions. SFA Inc., Frederick Manufacturing Division's warranty does not apply to these items since typically these individual equipment warranties provide coverage to the Government. Weatherhaven warrants the MECC to be free from defects in materials and workmanship for a period of one year from date of manufacture.

SFA Inc./Weatherhaven warrants all CK systems to be in compliance with the Performance Specification, Statement of Work, and design requirements as determined by the Government's first article testing of the first two CK systems.

NOMENCLATURE CROSS-REFERENCE LIST

<u>Common Name</u>	<u>Official Nomenclature</u>
CK	Containerized Kitchen (with Trailer)

LIST OF ABBREVIATIONS/ACRONYMS

The following abbreviations/acronyms are used in this manual

TERM	DEFINITION	TERM	DEFINITION
AAL	Additional Authorization List	ECU	Environmental Control Unit
AC	Alternating Current	EIR	Equipment Improvement Recommendation
AMC	Air Mobility Command	EMP	Electromagnetic Pulse
amp	ampere	FDA	Food and Drug Administration
AVIM	Aviation Intermediate Maintenance	FGC	Functional Group Code
AVUM	Aviation Unit Maintenance	ft	foot, feet
BII	Basic Issue Items	gal	gallon (U.S.)
BOI	Basis of Issue	GFI	ground fault interrupter
BTU	British thermal unit	gpm	gallons per minute
CAGEC	Commercial and Government Entity Code	GS	General Support
CB	Circuit breaker	HCI	Hardness Critical Item
cfm	Cubic feet per minute	Hz	Hertz (cycles per second)
CK	Containerized Kitchen (with Trailer)	in	inch, inches
COEI	Components of End Item	ISO	International Organization for Standardization
CPC	Corrosion Prevention and Control	kg	kilogram
CSC	Convention for Safe Containers	kW	kilowatt
CTA	Common Table of Allowances	lb	pound
°C	Degrees Celsius	LO	Lubrication Order
DA PAM	Department of the Army Pamphlet	MAC	Maintenance Allocation Chart
DC	Direct Current	MBU	Modern Burner Unit
DS	Direct Support	MCP	Main Control Panel
°F	Degrees Fahrenheit	MECC	Mobile Expandable Container Configuration

CONTAINERIZED KITCHEN (WITH TRAILER)
GENERAL INFORMATION

TERM	DEFINITION	TERM	DEFINITION
MTOE	Modified Table of Organization and Equipment	RPSTL	Repair Parts & Special Tools List
NBC	Nuclear, Biological, and Chemical	SF	Standard Form
NHA	Next Higher Assembly	SMR	Source, Maintenance and Recoverability
NSF	National Sanitation Foundation	SRA	Specialized Repair Activity
NSN	National Stock Number	SS	Stainless Steel
OD	outside diameter	TMDE	Test Measurement and Diagnostic Equipment
PDP	Power Distribution Panel	TQG	Tactical Quiet Generator
PEP	Power Entrance Panel	TOE	Table of Organization and Equipment
PMCS	Preventive Maintenance Checks and Services	UL	Underwriters Laboratories
P/N	Part Number	U/M	Unit of Measure
psig	pounds per square inch gauge	UOC	Usable On Code
PVC	polyvinyl chloride	UUT	Unit Under Test
qty	quantity	UV	Ultraviolet
		V	Volt, volts
		VAC	Volts Alternating Current
		VDC	Volts Direct Current
		WP	Work Package

CONTAINERIZED KITCHEN (WITH TRAILER)
EQUIPMENT DESCRIPTION AND DATA

EQUIPMENT CHARACTERISTICS, CAPABILITIES AND FEATURES

The Containerized Kitchen (with Trailer) [CK] is a mobile, self-contained field kitchen configured in an 8-ft by 8-ft by 20-ft International Organization for Standardization (ISO) container. The container meets all ISO and U.S. Coast Guard requirements for safe containers, including nine-high stacking. The dry weight of the CK system, excluding the trailer, is approximately 14,080 lb (6392 kg). It is transportable in C-130 and larger Air Mobility Command (AMC) aircraft. When mounted on its trailer as shown in Figure 1, it is capable of being externally transported (sling loaded) by a CH-47D rotary wing aircraft. The CK can withstand the shocks and vibrations encountered in ground transportation by either rail or truck without damage, and when mounted on its trailer can be transported over primary roads, secondary roads, and cross-country terrain.

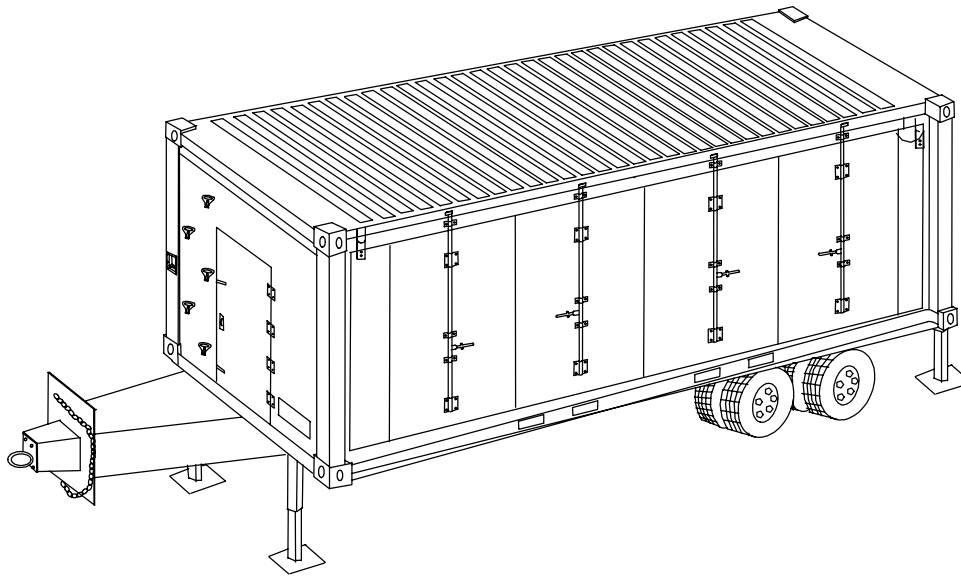

Figure 1. CK Mounted on Trailer.

When configured for food preparation, the CK provides approximately 360 square feet of food preparation and serving areas protected from natural elements of the environment. All food preparation equipment, the electrical supply, the environmental control system, and all related controls are mounted inside the CK.

The CK is capable of preparing and serving up to 800 Army field menu meals (A-Ration, Heat and Serve Ration or any combination) up to three times per day. An A-Ration meal can be prepared in less than three hours.

The CK requires less than 45 minutes to set up or tear down by a crew of four personnel and a supervisor. It has the capability to prepare and serve meals while mounted on a towed trailer or while dismantled.

CONTAINERIZED KITCHEN (WITH TRAILER)
EQUIPMENT DESCRIPTION AND DATA

Integrated equipment includes a griddle, steam table, cook pot cradles, tray pack heater, and an oven, all heated by Modern Burner Units (MBUs). A permanent fuel distribution system provides fuel to the MBUs, eliminating the need for the cooks to handle fuel within the kitchen. Two refrigerators with a combined volume of 58.4 cubic feet are included. A hand sink for hot and cold potable water, an electric mobile warming cabinet, two mobile storage cabinets, a mobile pan rack, and four food preparation/serving tables are also provided. The kitchen also includes pots, pans, baking sheets, roasting pans, insulated food and beverage serving containers, and a full complement of cooking and serving utensils. Sufficient cabinet and drawer space is provided to house all of the included equipment. A rifle rack, mounted on the wall beside the personnel access door, provides storage for the crew's weapons.

The CK contains a 10kW Tactical Quiet Generator (TQG), and provisions for receiving power from an external source. It includes both normal (white) and red (blackout) lighting. A full array of controls and indicators are provided, including an emergency shutoff switch to rapidly shut off all power to the kitchen in the event of an emergency.

The CK can operate under all external ambient conditions anticipated for a mobile military system, including temperatures ranging from -25°F to +120°F. It includes an integrated environmental control system designed to maintain a reasonably comfortable operating environment for the cooks.

**CONTAINERIZED KITCHEN (WITH TRAILER)
EQUIPMENT DESCRIPTION AND DATA**

LOCATION AND DESCRIPTION OF MAJOR COMPONENTS

The CK provides approximately 390 square feet of enclosed floor space. About 30 square feet is used as a mechanical room to house the generator, air conditioners, and ventilation fans. The remaining space encompasses the food preparation and serving areas. Figure 2 and Figure 3 illustrate the kitchen layout, which allows five cooks to work efficiently, comfortably, and conveniently.

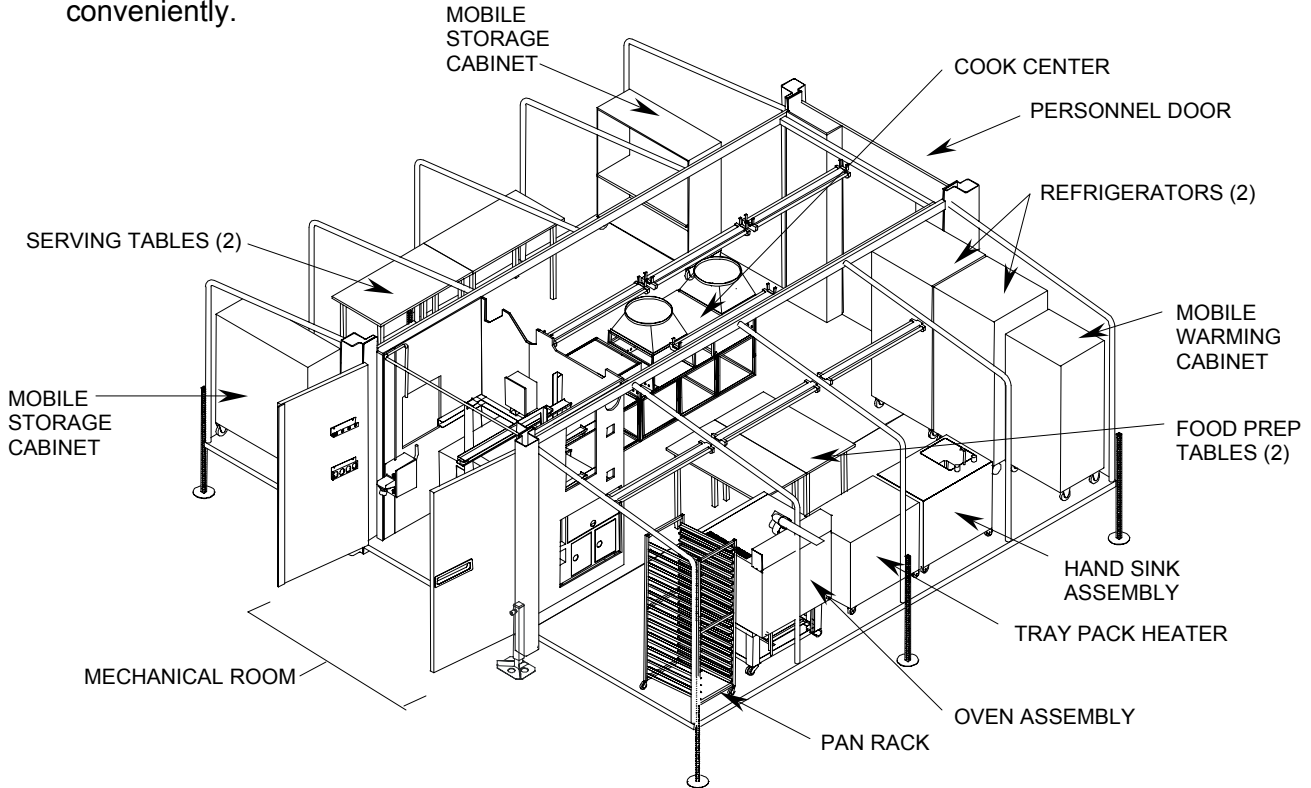

Figure 2. Containerized Kitchen (with Trailer) [CK], Food Preparation Side View.

CONTAINERIZED KITCHEN (WITH TRAILER) EQUIPMENT DESCRIPTION AND DATA

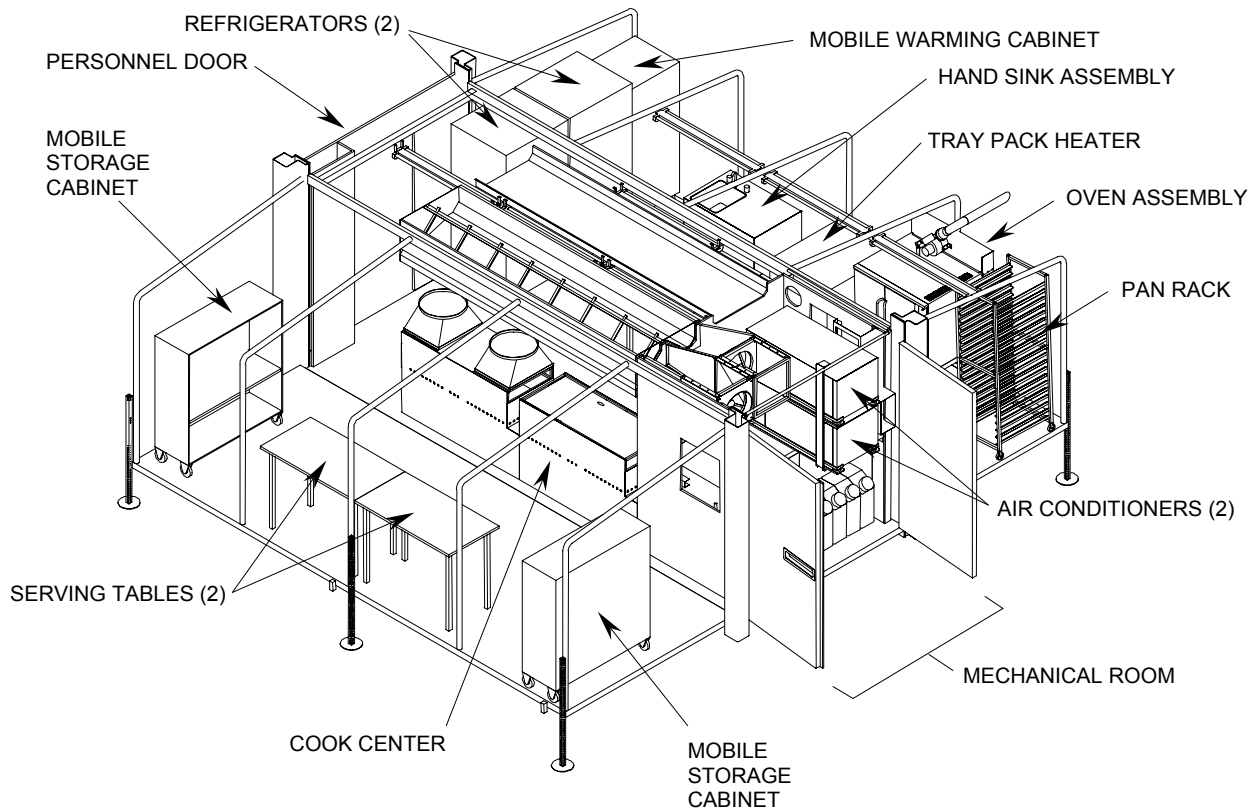

Figure 3. Containerized Kitchen (with Trailer) [CK], Serving Side View.

Figure 4 shows the cook-equipment interface during meal preparation, and illustrates the area of operation for the five cooks. Each cook has access to the central island, consisting of two food preparation tables. Cook #1 is a support person having access to the refrigerators, sink and mobile warming cabinet. Cook #2 has access to the oven, pan rack, and the tray pack heater. Cook # 3 has access to the oven, generator controls, spice rack, and the electrical controls (not illustrated) to the right of the spice rack. Cook #4 and Cook #5 have access to the griddle and steam table/cooking racks, respectively.

CONTAINERIZED KITCHEN (WITH TRAILER) EQUIPMENT DESCRIPTION AND DATA

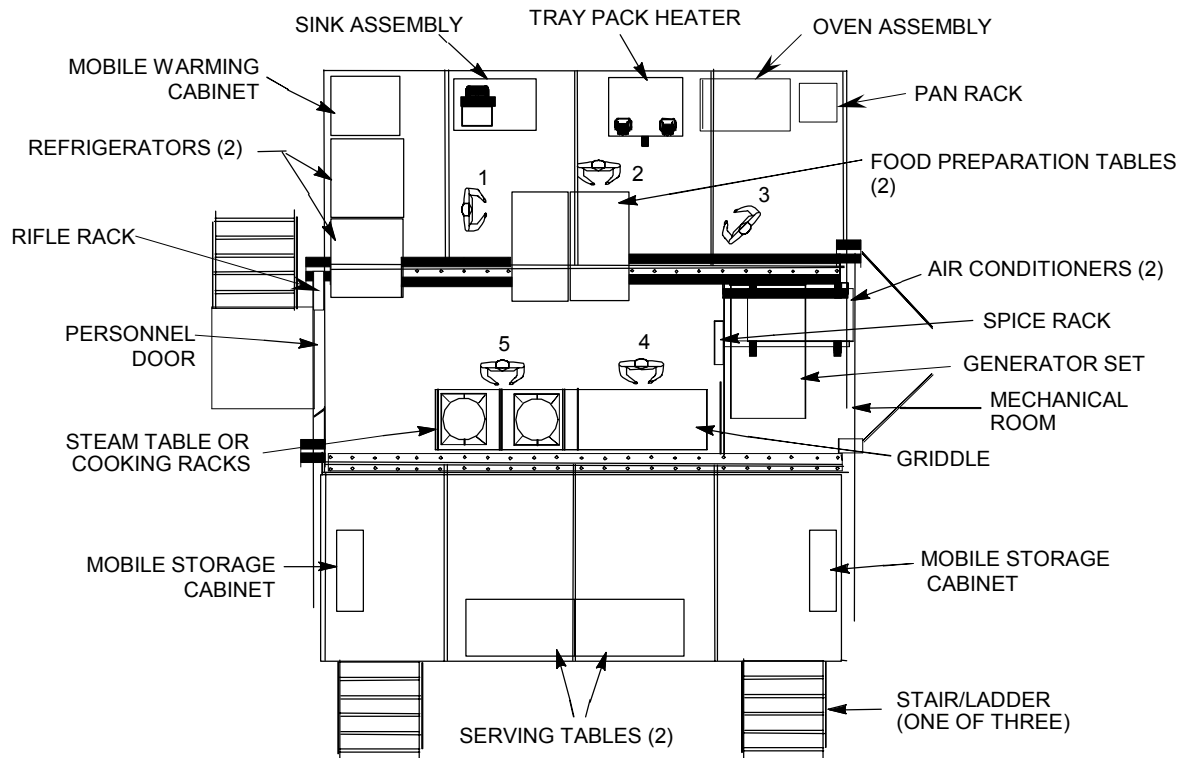

Figure 4. Cook/Equipment Interface.

The overall layout of the CK is oriented around a central cook center located in the shelter core. The cook center houses four MBUs which can heat any two of the following: the griddle, the steam table, or two cook pots, any of which can be set up on either the left or right half of the cook center. The cook center also serves as the dividing line between the food preparation and the serving areas. An aisleway allows personnel to freely move between the two areas without exiting the shelter. Integral to the cook center are provisions for both electrical and fuel connections for five MBUs. Four of these connections are fixed within the cook center to accommodate the cook pots, the griddle, and the steam table. A fifth connection at the aisleway supplies the tray pack heater or the cook pot cradle assembly. The cook center also has a tray slide on the serving side for soldiers to use. A ventilation exhaust system is mounted above the heat and steam-producing appliances on the cook center, extending its full length.

In the center of the work space, two tables are set up as a food preparation island which is accessible from all areas of the kitchen and convenient for all five cooks. The refrigerators, warming cabinet, sink, tray pack heater, oven, and pan rack are located along the perimeter of the expandable sidewalls. The tray pack heater and the oven are located at the mechanical room end, with electrical and fuel connections provided. Most of the A-Rations loaded into the CK require refrigeration, so the refrigerators are located next to the personnel access door. In the serving area, two field tables and two storage cabinets are provided. Two access doors on this side of the expandable shelter provide access to the serving area. Personnel enter one door and exit the other. The field tables can be used as an extra length of food preparation surface or for laying out condiments while food is being served.

CONTAINERIZED KITCHEN (WITH TRAILER) EQUIPMENT DESCRIPTION AND DATA

The mechanical room, Figure 5, houses the CK's utility components. These include the generator, air conditioners, ECU controller, MBU converter, electrical distribution panels and ventilation fans. The generator is mounted on the floor, with the air conditioners and ventilation fans mounted above. An extension pipe routes the engine exhaust to the outside. A second extension directs the engine radiator cooling air to the outside through a cloth duct. Cloth ducts also route the ventilation system exhaust fan discharge and the air conditioner condenser cooling air to the outside.

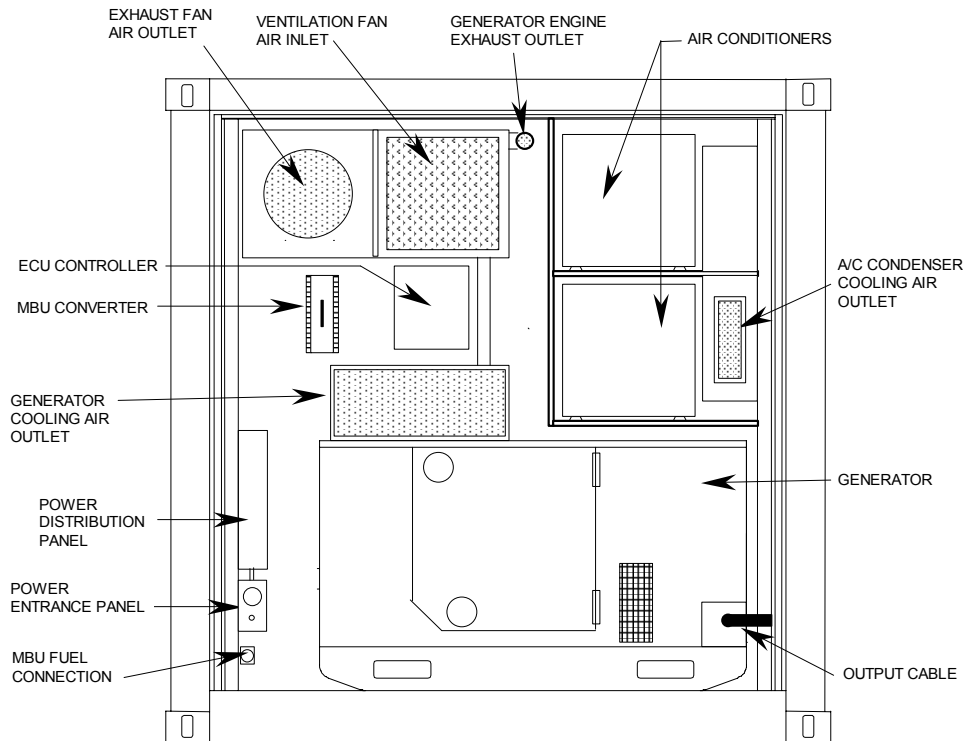

Figure 5. Mechanical Room.

Exterior doors provide access to the mechanical room for installation, removal, and maintenance of the utility systems. These doors seal the mechanical room from external environmental conditions such as rain, sand, dust and salt spray during transport. They must remain open while in the operational mode to provide for generator and ventilation system exhaust. A foldout awning, stored in the mechanical room, can be deployed across the top of the open doors to provide protection from rain, sand, and dust.

Controls for the ECU, cook center ventilation, and MBU power are located on the food preparation side of the mechanical room wall, near the cook center. An access door with a transparent window, located in the bottom portion of the wall, provides access to generator's control and malfunction indicator panels.

**CONTAINERIZED KITCHEN (WITH TRAILER)
EQUIPMENT DESCRIPTION AND DATA**

The Container Safety Certification Plate and System Identification Plates are located to the left of the personnel access door at the end of the shelter core. These are illustrated in Figure 6 and Figure 7, respectively.

CSC SAFETY APPROVAL

MANUFACTURED BY:  **Weatherhaven™**
5700 Marine Way, Burnaby, B.C. Canada
 Phone (604) 451-8900 Fax (604) 451-8999

MANUF. SERIAL NUMBER:

DATE MANUFACTURED:

US PATENT NO. 5,761,854

TESTING CONDUCTED AT: TRI-METAL FABRICATORS I.D. NUMBER:

MAXIMUM GROSS WEIGHT:	<input type="text" value="10,886"/> KG	<input type="text" value="24,000"/> LB
MAXIMUM PAYLOAD:	<input type="text" value="6,800"/> KG	<input type="text" value="15,000"/> LB
ALLOWABLE STACKING WEIGHT FOR 1.8 g	<input type="text" value="86,471"/> KG	<input type="text" value="190,637"/> LB
RACKING TEST LOAD VALUE	<input type="text" value="4,672"/> KG	<input type="text" value="10,300"/> LB
END WALL STRENGTH	<input type="text" value="2,722"/> KG	
SIDE WALL STRENGTH	<input type="text" value="4,082"/> KG	

NEXT EXAMINATION DUE (MONTH & YEAR)

ELECTRICAL SPECIFICATIONS

VOLTAGE	AMPERAGE	PHASE	WIRE	FREQUENCY
<input type="text"/>	<input type="text"/>	<input type="text"/>	<input type="text"/>	<input type="text"/>

Figure 6. Container Safety Certification Plate.

NOMENCLATURE:

PART NUMBER:

SERIAL NUMBER:

CONTRACT NO:

CAGE CODE:

NSN:

GROSS WEIGHT:

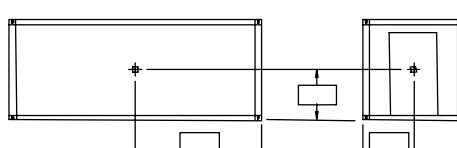

STA FREDERICK MFG. DIV.

NOMENCLATURE:

PART NUMBER:

SERIAL NUMBER:

CONTRACT NO:

CAGE CODE:

NSN:

GROSS WEIGHT:

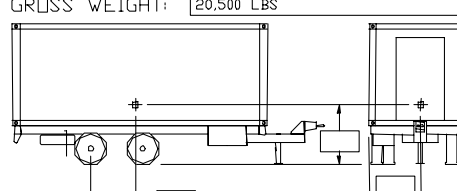

STA FREDERICK MFG. DIV.

Figure 7. CK Identification Plates.

In the transport mode, the CK provides the necessary space, storage area, and tie-downs required to stow all items of the system inside the container. The equipment packout is configured to distribute the weight throughout the container as evenly as possible.

CONTAINERIZED KITCHEN (WITH TRAILER) EQUIPMENT DESCRIPTION AND DATA

Shelter

The CK shelter, Figure 8, consists of a fixed, rigid core with two hinged, expandable wings. The all-steel frame structure of the shelter core is designed to ISO specifications and meets the dimensional requirements of ISO Standards 668 and 1161, as well as U.S. Coast Guard requirements for safe containers in accordance with the international Convention for Safe Containers (CSC). When configured to its compact ISO shipping format, the shelter is easily transported by truck, rail, sea, or air. The shelter has been tested and certified to nine-high stacking and thus permits the stacking of eight fully loaded ISO containers on top of one. The shelter floor area expands to provide about 360 square feet of sheltered floor space.

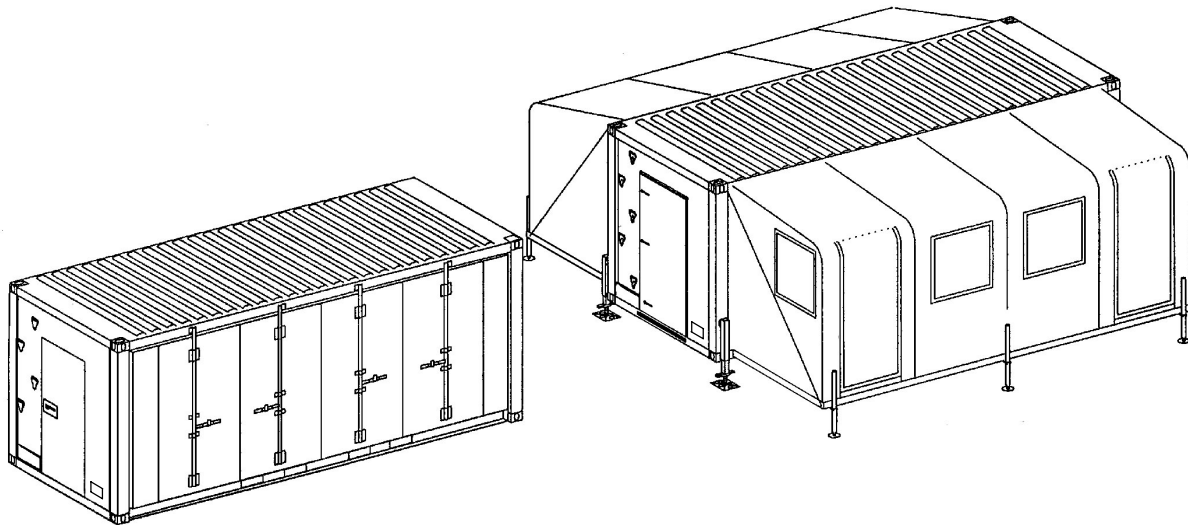

Figure 8. The CK Shelter.

The expandable side walls are hinged at the container base, sealed with rubber weatherproof seals, and incorporate four anti-racking door locks which are used in the transport mode. The side walls are lowered by mechanical winches to form the floors of the wings when the kitchen is deployed.

Each side wall of the shelter incorporates an insulated fabric section that provides the roof, side, and end walls of the expandable wing. The fabric section is permanently attached and sealed to the container framework with a watertight butyl rubber tape to prevent leakage. The fabric section consists of three layers: an external durable, UV-resistant and weatherproof vinyl coated polyester soft wall cover, an opaque insulation layer, and an inner liner. The expandable fabric cover is manufactured from technologically advanced vinyl that exhibits high tear strength, fire retardance, and resistance to mildew and ultraviolet radiation. The cover material is designed for use in ambient conditions from -67°F to +149°F.

The fabric cover is supported by steel arches, which use a spreader mechanism to put tension on the cover. The arches are disassembled and stored in vinyl bags for packout.

Cook Center Assembly

The cook center assembly, Figure 9, houses four MBUs over which any two of the following can be placed: the griddle, the steam table and adapter top, or two cook pot cradle adapters and cook pot cradles. Any of these items can be set up on either half of the cook center. The cook center includes a base foundation with storage areas, and mounts the serving line tray slide.

**CONTAINERIZED KITCHEN (WITH TRAILER)
EQUIPMENT DESCRIPTION AND DATA**

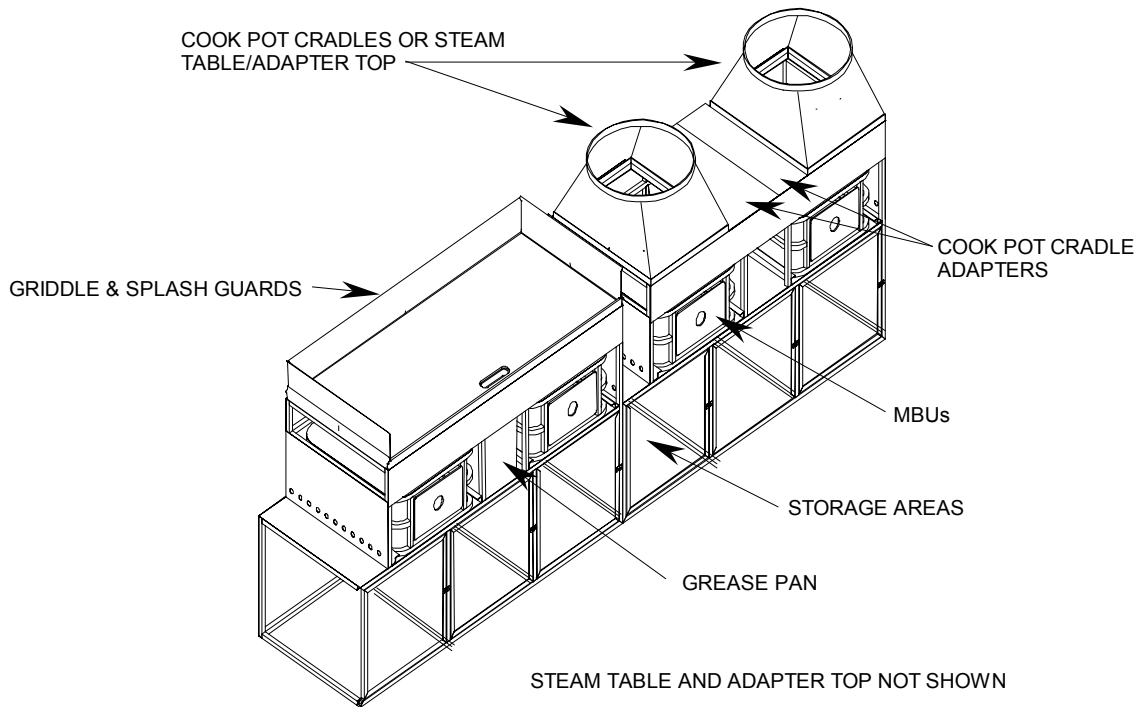

Figure 9. Cook Center Assembly.

Cook Pot Assembly

The cook pot assembly, Figure 10, allows the use of a cook pot while the cook center is configured with the griddle and steam table. The assembly consists of a base rack; a burner rack; and one of the cook pot cradle adapters, cook pot cradles, and MBUs. The assembly can be placed at the end of the cook center or to the left of the oven assembly, where there are fuel and electrical connections for the MBU.

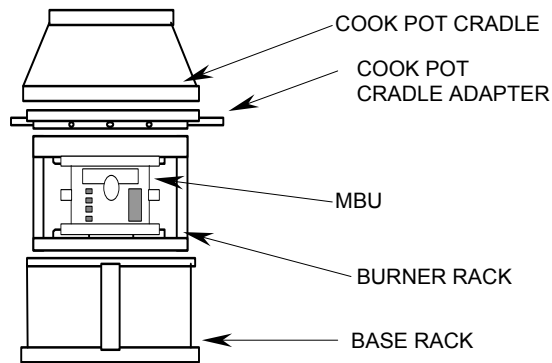

Figure 10. Cook Pot Assembly.

CONTAINERIZED KITCHEN (WITH TRAILER) EQUIPMENT DESCRIPTION AND DATA

Oven Assembly

The oven assembly, Figure 11, consists of an MBU-fired convection oven mounted on a mobile base cabinet. Integral casters allow it to be easily moved between its operational and transport locations. The assembly includes an integral exhaust gas oven fan and chimney pipe that penetrates the fabric wall when positioned for operation. Positioning rails, permanently attached to the floor at the assembly's operational location, position it with the correct clearance to prevent damage to the walls from overheating.

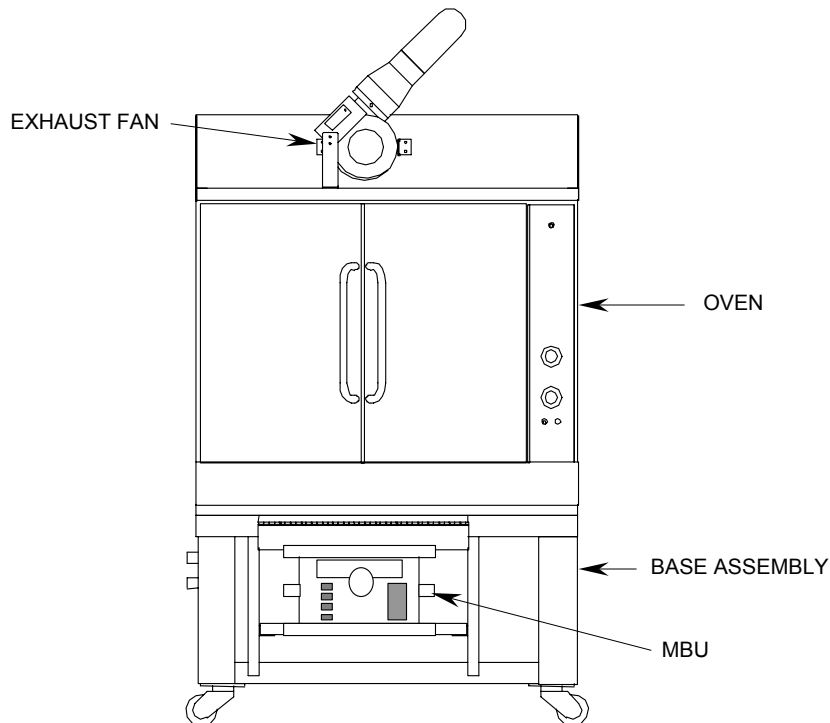

Figure 11. Oven Assembly.

Refrigerators

Two refrigerators provide approximately 58 cubic feet of refrigerated storage. The refrigerators use R-134a refrigerant, which is commercially available, environmentally safe, and non-ozone-depleting.

Mobile Warming Cabinet

The mobile warming cabinet holds up to 10 full-size, 6-inch-deep steam table pans. Removable/adjustable slides are provided in the cabinet. Each slide can hold two standard pans. The cabinet has double doors with latches to hold them closed during transport and is equipped with heavy-duty swivel casters, two with brakes. A thermometer on the control panel displays the cabinet's internal temperature.

Hand Sink Assembly

The hand sink assembly, Figure 12, is a modular, self-contained hand washing station consisting of a sink, faucet, water heater, pump, wastewater drain, liquid soap dispenser, and paper towel dispenser integrated into a mobile aluminum cabinet. The cabinet has four swivel casters, two with brakes, for easy movement between the transport and operational mode locations.

CONTAINERIZED KITCHEN (WITH TRAILER) EQUIPMENT DESCRIPTION AND DATA

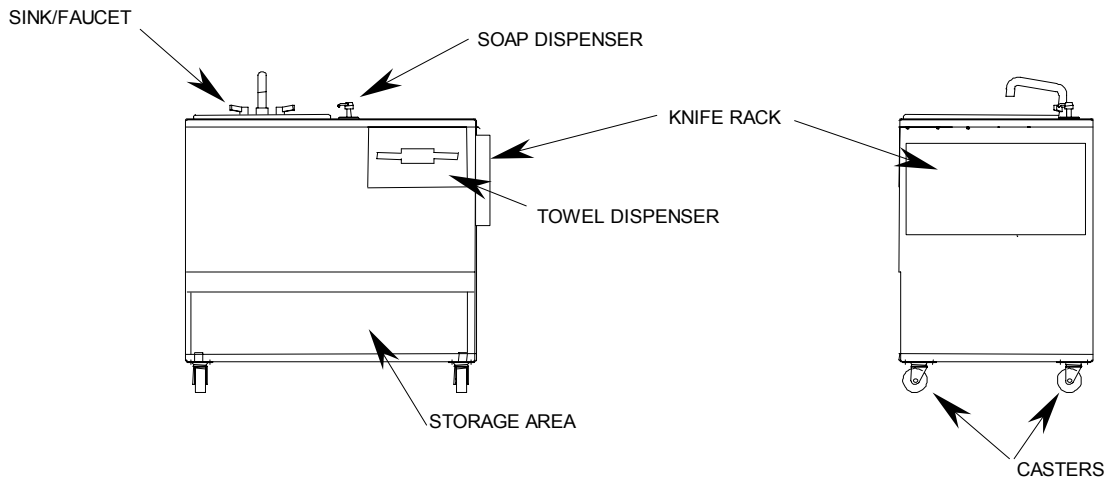

Figure 12. Hand Sink Assembly.

Potable water from any non-pressurized external source is routed to a hose connection on the back of the cabinet. An on-demand, diaphragm pump draws water to the sink. The pump is designed for drinking water use, and is self-priming. It includes a check valve to prevent reverse flow and an integral pressure switch to detect water pressure and provide the on-demand feature. The maximum flow rate is approximately 3 gpm.

Drain cocks at the low points in the sink's plumbing allow all of the piping and the water heater to be drained for packout. In the transport mode, the water supply hose, external drain hose, and interior drain hose are packed in storage spaces at the bottom of the sink cabinet.

Tray Pack Heater

The CK includes a modified tray pack heater which is positioned to the left of the oven assembly. The heater connects to the fuel and power lines on the back of the oven base.

Pan Rack

A pan rack, equipped with casters, provides storage for up to 20 baking and roasting pans.

Generator

A MEP-803A Tactical Quiet Generator (TQG) is located in the mechanical room, separate from the cooking and serving areas. The generator's controls and indicators are accessible through a door in the oven side of the mechanical room wall. Access to the generator for routine maintenance is through a second door in the mechanical room wall, next to the cook center, and through the exterior doors of the mechanical room. Refer to TM 9-6115-642-10 for more information about the generator.

Power Entrance Panel and External Power

The CK can be powered by an external source via the Power Entrance Panel (PEP), located next to the generator. This panel is a "waterfall" type that allows easy strain relief for the power cable and connector. External power can be provided from a 120/208 volt, 50/60 Hz, 60 amp, 5-wire, 3-phase source. The power is connected through a box-mounted receptacle with flange ring. A grounding terminal below the receptacle provides a connection for earth ground.

**CONTAINERIZED KITCHEN (WITH TRAILER)
EQUIPMENT DESCRIPTION AND DATA**

Lighting

Nine dual-tube, fluorescent fixtures provide the CK's interior lighting. Six provide white light for normal operations and three have red filters to provide blackout lighting. The normal and blackout lights are located as shown in Figure 13. Four of the fixtures are permanently mounted in the core of the kitchen. The rest are removable and are divided between the two wing sections. The removable fixtures attach to the wing arch supports and are removed for packout.

The white light fixture nearest the personnel access door contains a rechargeable nickel-cadmium battery and circuitry to provide emergency lighting. If power to the CK is lost, this fixture will operate for at least 90 minutes, providing light for personnel to evacuate the kitchen. It can also be used to provide lighting during kitchen setup, until electrical power is connected. The battery automatically recharges when power is connected to the kitchen. A test switch on the fixture allows for testing operation of the emergency light feature.

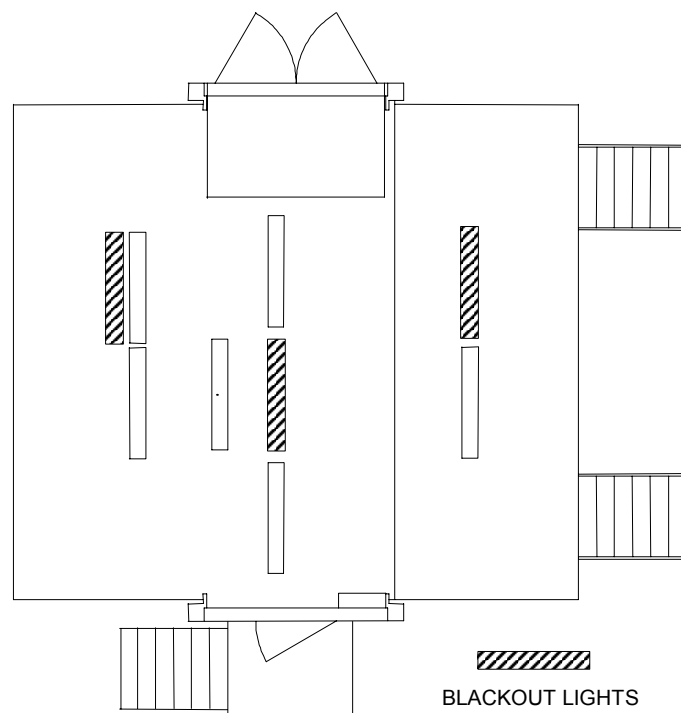

Figure 13. Lighting Fixture Layout.

The lighting controls, described in detail in WP 0003 00, include switches for operating the lights and for selecting the lighting mode (normal or blackout).

Exhaust System

The principal component of the CK's exhaust system is the exhaust hood mounted over the length of the cook center, Figure 14. Heat, water vapor, and fumes rising from the cook center equipment are exhausted by the hood. The hood also includes a makeup air supply to prevent conditioned air in the kitchen from being drawn out by the hood, and an air curtain that contains the heat from the cook center until it is drawn out by the exhaust fan.

CONTAINERIZED KITCHEN (WITH TRAILER) EQUIPMENT DESCRIPTION AND DATA

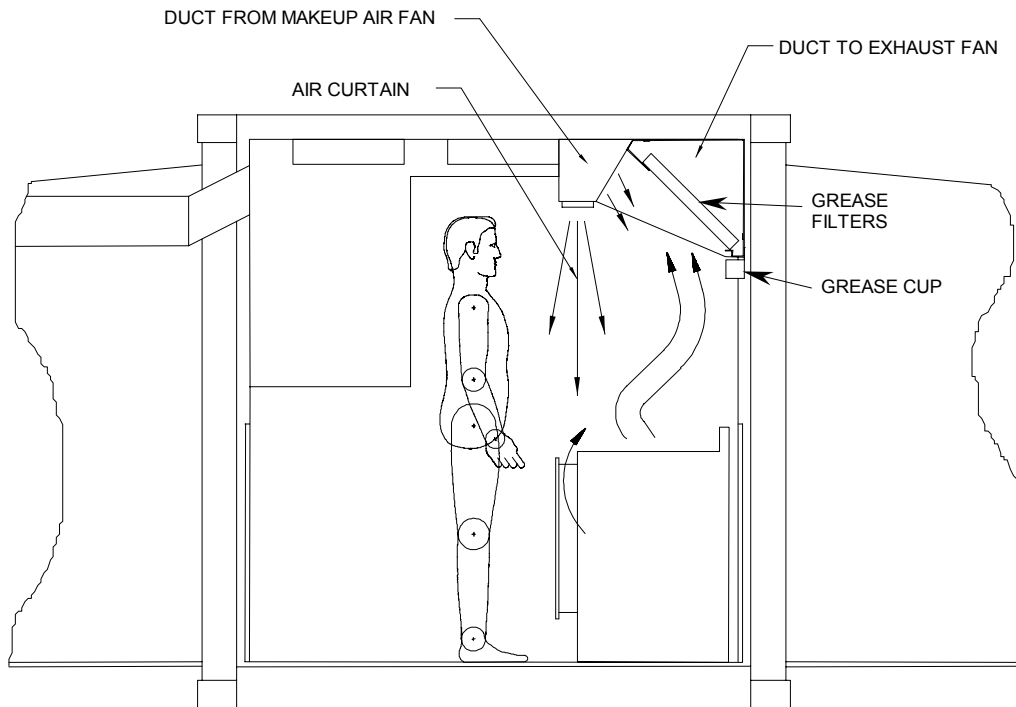

Figure 14. Cook Center Exhaust Hood.

The exhaust hood includes removable, washable, aluminum baffle-type grease filters. A tilted grease trough beneath the filters collects grease and directs it to a removable collection cup.

Air supply and exhaust are provided by two identical, variable-speed fans located in the mechanical room. Under normal conditions, the fans operate at approximately 60 to 75% capacity. The remaining capacity provides for unusual conditions when large amounts of smoke or steam must be exhausted from the kitchen.

Environmental Control System - ECU

The Environmental Control System consists of two dual-stage air conditioners located in the mechanical room, three heating elements located in the air conditioner evaporator discharge plenum, fixed and removable ductwork, filters, and an Environmental Control Unit (ECU). Components of the ECU include a wall-mounted mode selector switch in the food preparation area and a controller mounted on the back wall inside the mechanical room.

Each air conditioner has a rated cooling capacity of 24,000 BTU/hr, and contains two independent compressors. Under the control of the ECU, the four compressors operate independently to provide staged cooling capacities of 12,000 BTU/hr, 24,000 BTU/hr, 36,000 BTU/hr, and 48,000 BTU/hr. ECU operation is described in detail in WP 0003 00.

When the heaters are operating, one air conditioner fan runs to circulate the heated air. The heaters are designed to provide only limited control of kitchen temperature without overloading the generator. The principal source of kitchen heating is the MBUs during cooking operations.

CONTAINERIZED KITCHEN (WITH TRAILER)
EQUIPMENT DESCRIPTION AND DATA

Spot cooling and heating of various parts of the food preparation area is controlled by several manually adjustable vent openings in the fixed ceiling duct in the shelter core. The ECU is not designed to heat and cool the entire kitchen, but only to maintain a reasonably comfortable working environment for the cooks.

DIFFERENCE BETWEEN MODELS

Not applicable.

EQUIPMENT DATA

Length: 20 ft (6.1m)

Width: 8 ft (2.44 m)

Height: 8 ft (2.44 m)

Weight: 14,080 lb (6392 kg)

**CONTAINERIZED KITCHEN (WITH TRAILER)
THEORY OF OPERATION**

COOKING EQUIPMENT – MBUs

Operation of the MBUs is described in detail in TM 10-7310-281-13&P.

The MBUs receive fuel through a refueling system which provides fuel to seven locations (five in the cook center and two in the oven assembly). In the mechanical room, fuel comes from a 5-gallon fuel can fitted with an adapter to which the fuel line is connected. The fuel line splits into two branches, one to the cook center peninsula and the other to a connection at the bottom of the food preparation area wall (near the access door for the generator controls). A fuel line assembly attached to the back of the oven base plugs into this connection to supply the oven and tray pack heater.

A power converter, mounted on the wall inside the mechanical room, provides 24 VDC power for the MBUs. A permanently mounted power cable runs the length of the cook center peninsula. A permanently mounted cable on the back of the oven assembly plugs into an outlet in the ceiling raceway to power the MBUs for the oven and tray pack heater. An ON/OFF, MBU POWER switch on the wall next to the cook center allows the operators to quickly shut off all MBUs.

ELECTRICAL SYSTEM

Input electrical power for the CK is 120/208 VAC, 60 Hz, three phase. Power is supplied from either the onboard generator or from an external source connected to the Power Entrance Panel (PEP) in the mechanical room (see WP 0002 00, Figure 5). Two sets of contactors in the PEP, operated by pushbutton switches on the Main Control Panel (MCP), connect the desired power source. Circuit interlocks prevent both sources from being connected at the same time.

The MCP displays the status of the power sources and contains the switches for source selection. It also contains the lighting controls and the emergency stop (E-Stop) switch.

The E-Stop switch uses the contactors in the PEP for emergency system shutdown. Depressing the E-Stop opens both sets of contactors, disconnecting both power sources to ensure that the distribution and control panels are completely de-energized. Contacts in the E-Stop also shut down the generator.

The Power Distribution Panel (PDP), located on the serving wing wall, receives power from the PEP and distributes it through individual circuit breakers to the various branch circuits of the kitchen.

ENVIRONMENTAL CONTROL UNIT (ECU)

The Environmental Control Unit circulates heated or cooled air to the occupied areas of the kitchen. Using a wall-mounted control switch, kitchen personnel select the desired operating mode (off, heat, low cooling or high cooling). The operation of this switch is described in detail in WP 0005 00.

The system draws air from the kitchen through a wall-mounted return air plenum in the food preparation area. Removable, washable filters in the plenum remove dust and other particulates. The air then passes through the air conditioners to the outlet plenum, in the process being heated or cooled. From the outlet plenum, the air is distributed throughout the kitchen through fixed ductwork.

The ECU provides automatic electrical load control to maximize the amount of available air conditioning. Each of the two air conditioners has two compressors. The ECU continuously

CONTAINERIZED KITCHEN (WITH TRAILER)
THEORY OF OPERATION

monitors total kitchen load and operates the four compressors independently to maximize cooling while keeping power consumption within the 10kW capacity of the generator. This feature also operates when the CK is using external power, limiting power consumption to 10kW regardless of the amount of external power available.

LIGHTING

Two switches on the MCP, INTERIOR LIGHTING and LIGHTING MODE, control the lighting circuit. When the INTERIOR LIGHTING switch is ON and the LIGHTING MODE switch is in NORMAL, the white lights are on. Placing the LIGHTING MODE switch in BLACKOUT turns off the white lights and turns on the red blackout lights.

Emergency lighting capability is included in the white light fixture nearest the personnel door. It consists of an internal, rechargeable nickel-cadmium battery, control circuit, power indicator light and a test switch. If power is lost, the light automatically comes on (or remains on if it was operating). Its internal battery, when fully charged, has enough power to operate the light at reduced illumination for at least 90 minutes, allowing the operators to evacuate the kitchen until power can be restored. The EMERGENCY LIGHT switch, located on the MCP, disconnects the battery from the light. The switch should be left ON whenever there is power to the kitchen so the battery will charge. It should be placed in OFF whenever the lights are intentionally turned off or power is removed from the kitchen. This saves the battery charge so that it is available at the next startup to provide lighting in the kitchen until the generator can be brought on line or external power connected. If the emergency light is left on long enough to drain the battery, it will take approximately 36 hours to fully recharge.

The emergency light is tested by operating the test switch on the fixture. Momentarily moving the switch causes the emergency light to come on. The switch returns to its previous position and the light goes out when the switch is released.

WATER SUPPLY & DRAINAGE SYSTEM

The CK potable water supply and wastewater drainage systems are shown in Figure 1. Potable water is supplied from an external source such as a 400-gallon, M149 water trailer. The water is routed to the onboard sink through a 50-foot, 5/8-inch diameter supply hose made of an FDA-approved material that is safe for drinking water. The brass end couplings have 3/4-inch diameter threads - male on one end and female on the other. The male end of the hose is passed through a penetration in the side of the fabric cover and connected directly to a female connection in the back of the sink cabinet. The sink assembly is described in detail in WP 0002 00.

CONTAINERIZED KITCHEN (WITH TRAILER) THEORY OF OPERATION

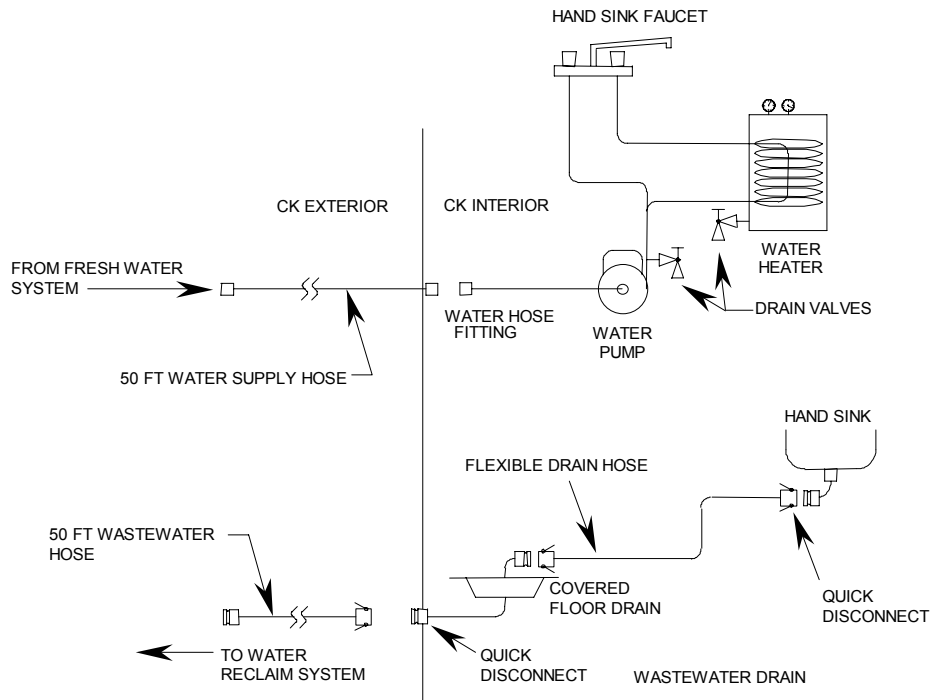

Figure 1. CK Drainage System.

Wastewater from the sink is routed inside the shelter, behind the refrigerators and mobile warming cabinet, through a flexible 1.25-inch diameter interior drain hose to the floor drain near the personnel access door. The drain hose ends have quick-disconnect couplings. One end connects to the sink and the other to a fitting on the top of the shelter floor drain grate. Wastewater from the floor drain and sink is piped through the shelter floor to an external 1.25-inch diameter male quick-disconnect near the personnel access door. A 50-foot, 1.25-inch diameter exterior drain hose routes the wastewater from that connection to a municipal drain or external reclaiming tank. Both ends of the exterior drain hose have 1.25-inch diameter quick-disconnect couplings. During transport mode, the drain hoses are coiled and stored in the hand sink assembly. A cover attached to the shelter exterior seals the external drain connection during transport.

**CONTAINERIZED KITCHEN (WITH TRAILER)
SUPPORT DATA FOR REPAIR PARTS, SPECIAL TOOLS, TMDE, AND SUPPORT
EQUIPMENT**

COMMON TOOLS AND EQUIPMENT

For common tools and equipment, refer to the Modified Table of Organization and Equipment (MTOE), CTA 50-970, Expendable/Durable Items, or CTA 8-100, Army Medical Department Expendable/Durable Items, as applicable to your unit.

SPECIAL TOOLS, TMDE, AND SUPPORT EQUIPMENT

No special tools or support equipment are required to maintain the CK. Refer to WP 0050 00 (Additional Authorization List) and WP 0052 00 (Tool Identification List) for a description of the necessary support items.

REPAIR PARTS

Repair parts are listed and illustrated in the Repair Parts and Special Tools List work packages, found in Chapter 6 of this manual.

TM 10-7360-226-13&P

CHAPTER 2
OPERATOR INSTRUCTIONS
FOR
CONTAINERIZED KITCHEN (WITH TRAILER) [CK]

CONTAINERIZED KITCHEN (WITH TRAILER)
DESCRIPTION OF OPERATOR CONTROLS AND INDICATORS

INTRODUCTION

Major controls and indicators for the CK consist of those for the generator, electrical power selection and control, lighting, MBUs, hand sink assembly, and cook center ventilation. Other miscellaneous controls include those for the mobile warming cabinet, refrigerators, oven, tray pack heater fan, and the environmental control unit (ECU).

GENERATOR

The generator control panel is located behind an access door on the food preparation side wall of the mechanical room. A detailed description of the generator's controls and indicators is provided in TM 9-6115-642-10.

ELECTRICAL POWER CONTROL AND LIGHTING**Power Entrance Panel**

The Power Entrance Panel (PEP), Figure 1, is located on the left mechanical room wall, just inside the left door. The power cable from the external source is plugged into the connection on the PEP. The ground terminal provides a connection for the grounding rod cable when energizing the CK from the generator. Push button circuit breakers for generator, external power, and emergency stop circuit control power are located on the side of the panel. These breakers pop out when tripped, and are pushed in to reset.

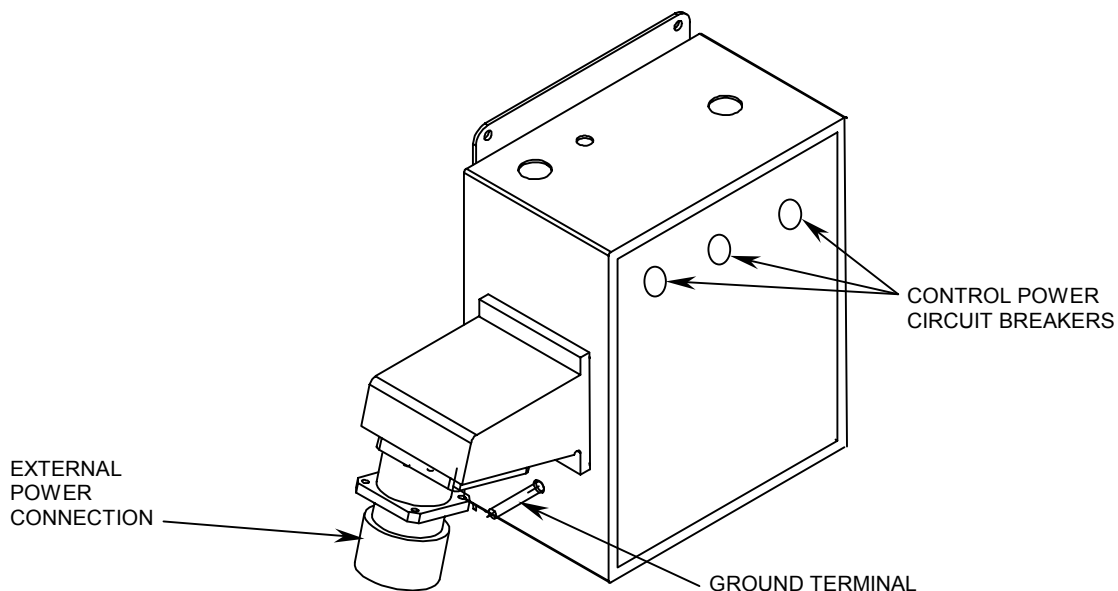

Figure 1. Power Entrance Panel.

**CONTAINERIZED KITCHEN (WITH TRAILER)
DESCRIPTION OF OPERATOR CONTROLS AND INDICATORS**

Power Distribution Panel

The Power Distribution Panel (PDP), Figure 2, is located on the mechanical room wall in the serving area. The panel houses the circuit breakers that control the distribution of electrical power within the kitchen. The circuit breakers are normally closed (ON) and are only opened (turned OFF) to isolate circuits for maintenance or troubleshooting. If an electrical malfunction occurs, the breaker in the affected circuit trips (opens) to isolate the affected circuit.

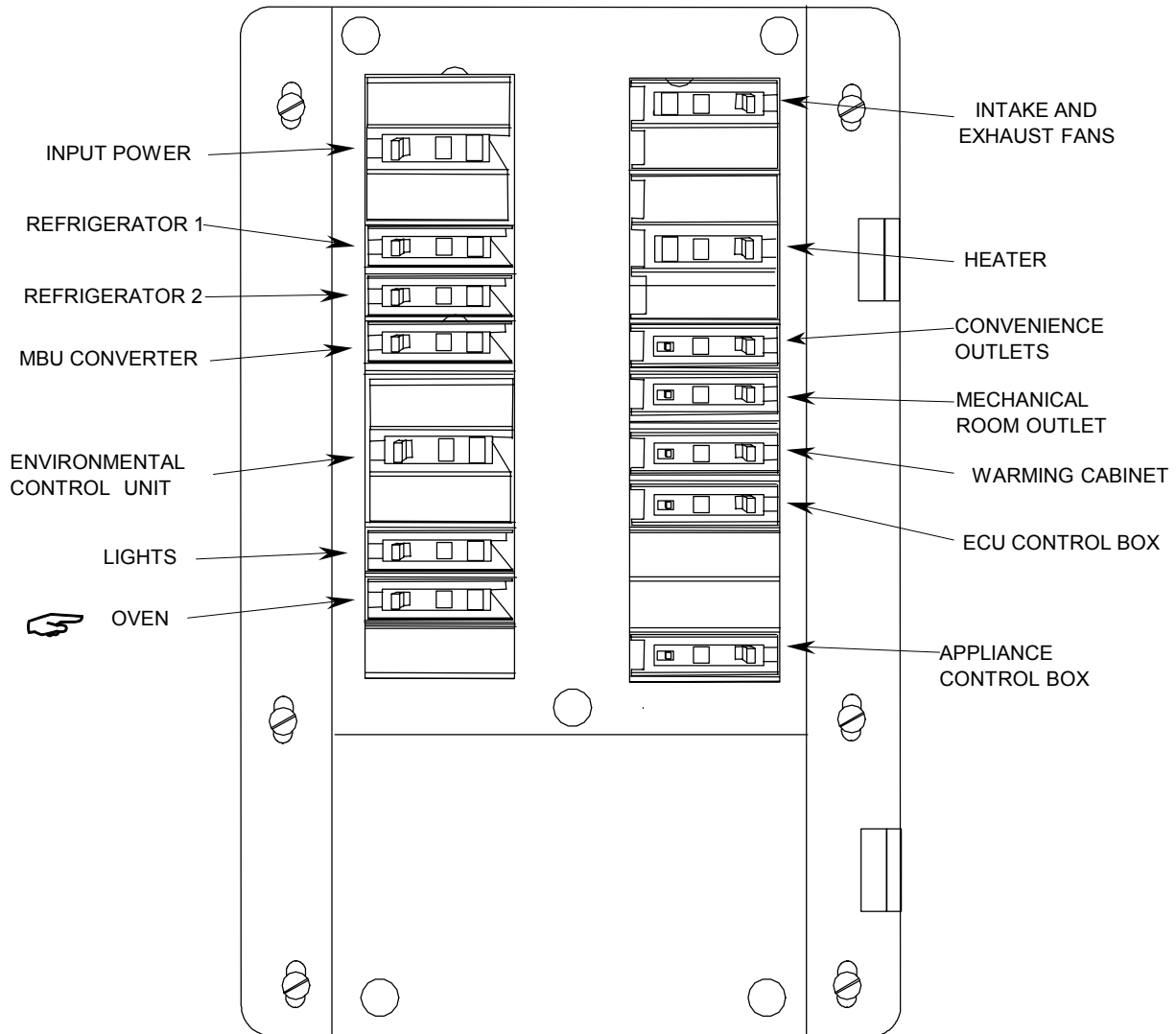

Figure 2. Power Distribution Panel.

CONTAINERIZED KITCHEN (WITH TRAILER)
DESCRIPTION OF OPERATOR CONTROLS AND INDICATORS

Main Control Panel

The Main Control Panel (MCP), Figure 3, is located in the food preparation area, on the wall to the right of the personnel access door. It houses the controls and indicators for selecting, connecting, and disconnecting electrical power, and for operating the CK's interior lights. These consist of the following:

- EMERGENCY STOP (E-Stop) pushbutton: Disconnects all electrical power from the CK in the event of an emergency. Shuts down the generator if it is running.
- Power OFF pushbutton: During normal operation, disconnects all electrical power from the CK. Does not shut down the generator.
- EXTERNAL POWER ON pushbutton: Connects external power to supply the CK. Lights green when external power is connected. Operates only if external power is available.
- GENERATOR POWER ON pushbutton: Connects generator power to supply the CK. Lights green when generator power is connected. Operates only if generator power is available.
- EXTERNAL POWER AVAILABLE indicator (amber): Lit when external power is available.
- GENERATOR POWER AVAILABLE indicator (amber): Lit when generator power is available.
- INTERIOR LIGHTING switch: Turns the interior lights ON and OFF.
- LIGHTING MODE switch: Selects NORMAL or BLACKOUT mode.
- EMERGENCY LIGHT switch: Connects (ON) and disconnects (OFF) the internal battery in the emergency lighting fixture. Whenever the kitchen is energized, the switch should be ON so the battery will charge. If the kitchen is de-energized, the switch should be turned OFF as soon as emergency lighting is no longer needed.

**CONTAINERIZED KITCHEN (WITH TRAILER)
DESCRIPTION OF OPERATOR CONTROLS AND INDICATORS**

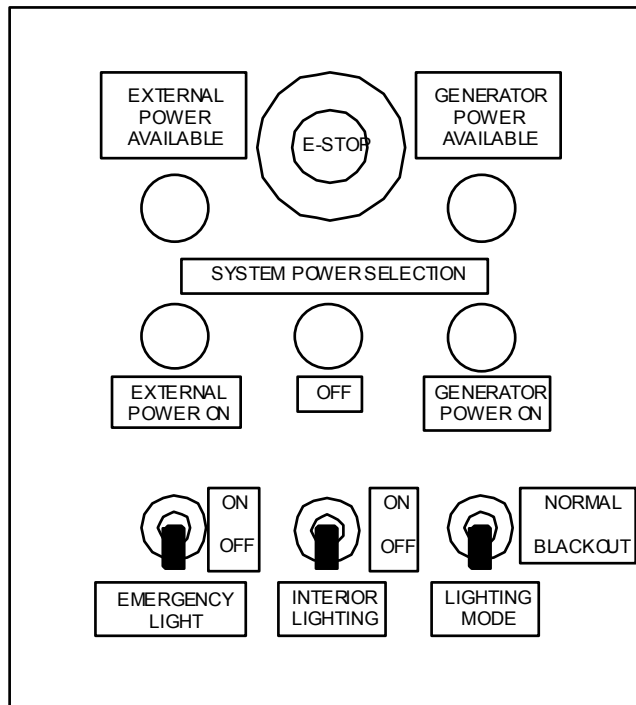

Figure 3. Main Control Panel.

MODERN BURNER UNIT (MBU)

MBU Power Switch

The MBU POWER switch, Figure 4, is located on the wall in the food preparation area, next to the spice rack. It is an ON/OFF toggle switch that controls the 120 VAC receptacle in the mechanical room that the MBU converter plugs into. Placing the switch in OFF shuts down all operating MBUs.

CONTAINERIZED KITCHEN (WITH TRAILER)
DESCRIPTION OF OPERATOR CONTROLS AND INDICATORS

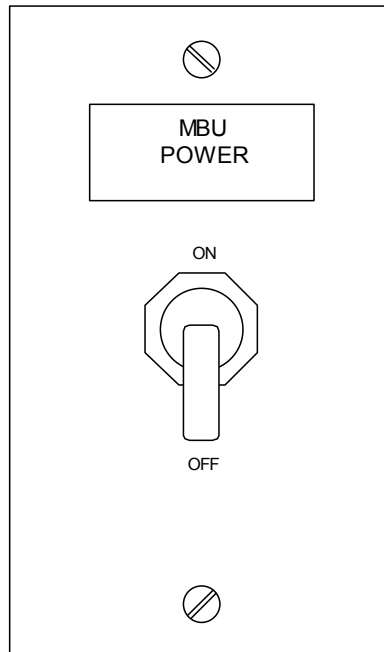

Figure 4. MBU Power Switch.

MBU Converter

The MBU converter, Figure 5, is mounted on the wall in the mechanical room, and has the following controls and indicators:

- MAIN POWER switch (1): Turns the converter ON and OFF.
- Output A (2): 24 VDC output connector #1.
- Output B (3): 24 VDC output connector #2.
- Indicator light (4): Lit when power is on.

CONTAINERIZED KITCHEN (WITH TRAILER) DESCRIPTION OF OPERATOR CONTROLS AND INDICATORS

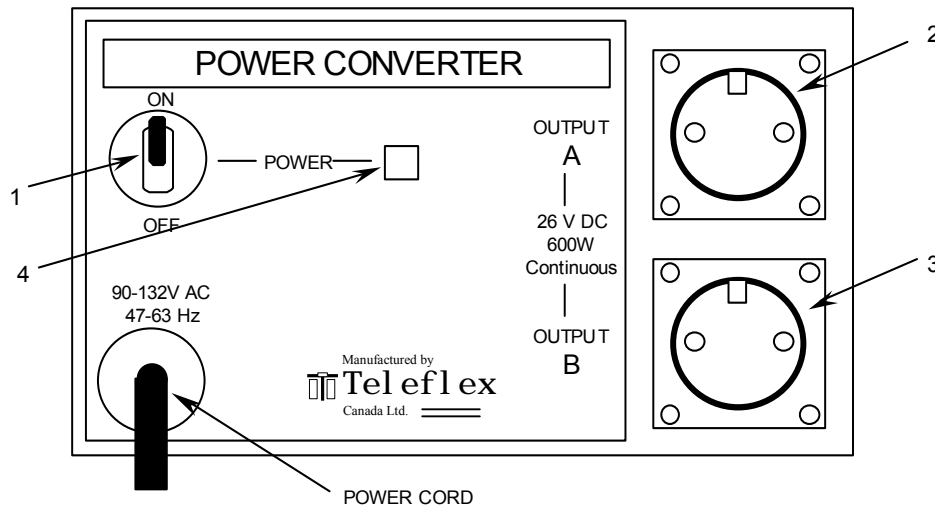

Figure 5. MBU Converter.

MBU Control Panel

Each MBU has an integral control panel, Figure 6. The MBU controls and indicators are listed below. Refer to TM 10-7310-281-13&P for more information about the MBUs.

- START pushbutton (1): Starts the burner.
- STOP pushbutton (2): Shuts down the burner.
- FUEL pushbutton (3): Starts the fueling function.
- POWER pushbutton (4): Turns the main power on and off.
- FIRING RATE control (5): Adjusts the burner firing rate.
- RUN indicator (6): Lights when the burner is operating.
- WARM UP indicator (7): Lights when the burner is warming up.
- FUELING/FUEL indicator (8): Lights when the tank is filling (during fueling) or full.
- LOW FUEL indicator (9): Lights when there is about 30 minutes of fuel remaining.
- VOLTAGE indicator (10): Lights when voltage from the power converter is incorrect.
- SERVICE indicator (11): Lights to indicate a malfunction.
- TOTAL HOURS indicator (12): Shows accumulated hours of operation. Displays error codes when malfunctions occur. Background light indicates power-on condition.

**CONTAINERIZED KITCHEN (WITH TRAILER)
DESCRIPTION OF OPERATOR CONTROLS AND INDICATORS**

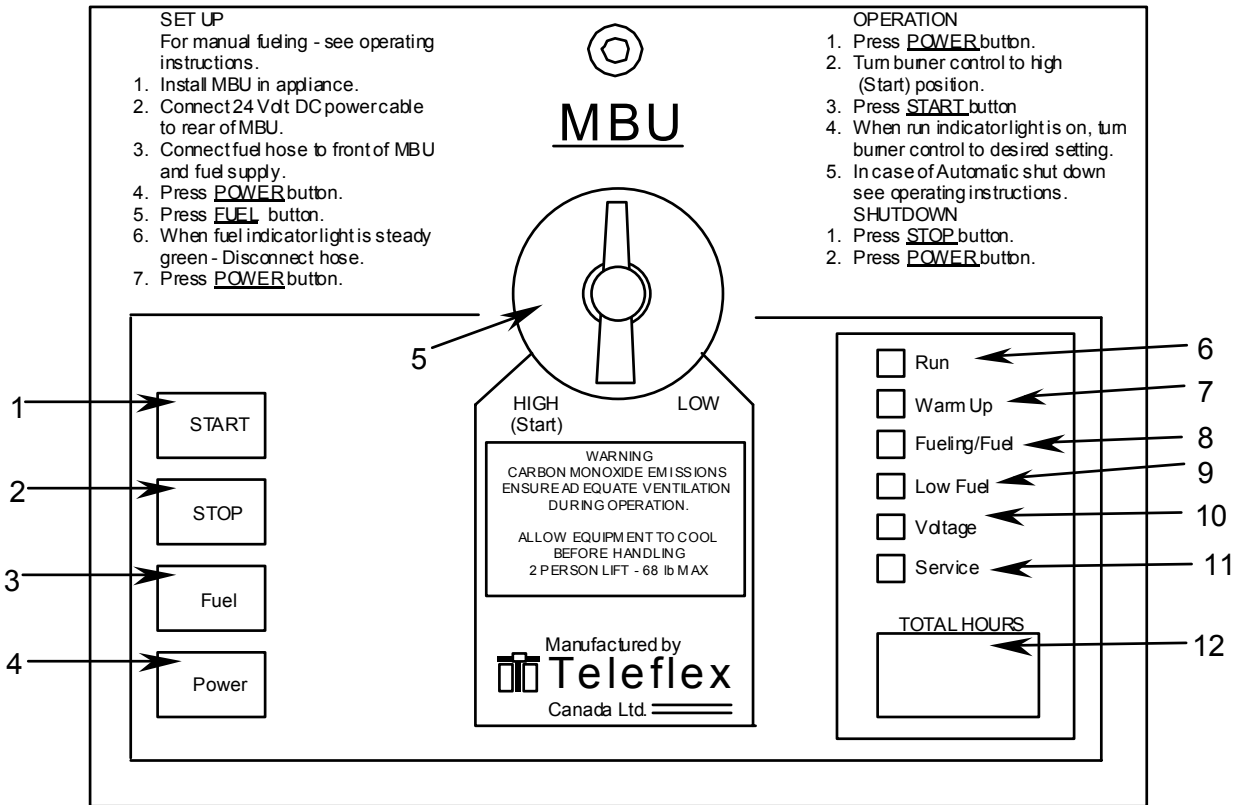

Figure 6. MBU Control Panel.

Appliance Control Box

The appliance control box, Figure 7, is located in the food preparation area. It is stored for packout, and is hung from one of the fabric arch supports for operation. It houses the control switches for the hand sink assembly water pump and water heater, and the tray pack heater fan. The controls include:

- WATER PUMP switch (1): ON/OFF toggle switch for the hand sink water pump.
- Circuit breakers (2): Pop out on overload. Push in to reset.
- HEATER FAN switches (3, 4): ON/OFF toggle switches for the tray pack heater fan. Only one switch is used for operation; the other is a spare.
- WATER HEATER switch (5): ON/OFF toggle switch for the hand sink water heater.
- Receptacles (6): Electrical connections for the appliances. Each appliance connection corresponds to the switch above it.

**CONTAINERIZED KITCHEN (WITH TRAILER)
DESCRIPTION OF OPERATOR CONTROLS AND INDICATORS**

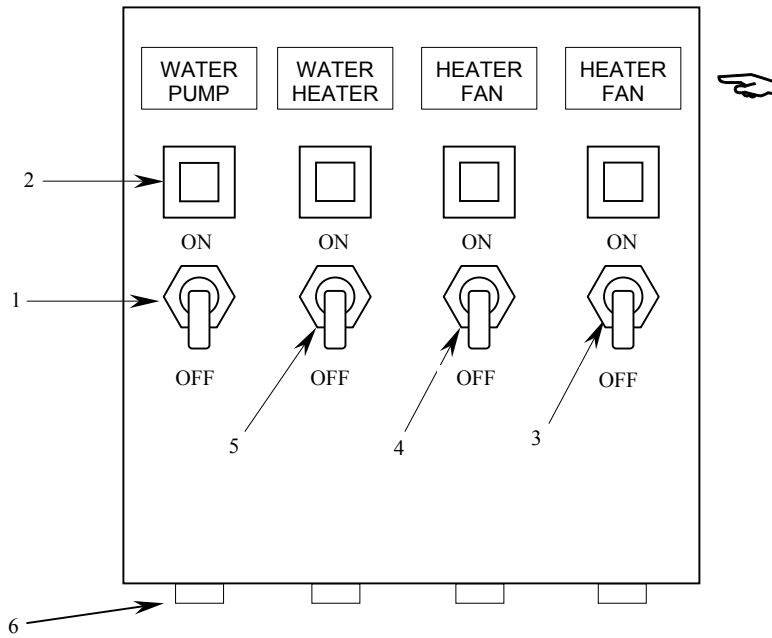

Figure 7. Appliance Control Box.

Cook Center Ventilation

The cook center exhaust hood intake and exhaust fans are controlled together by a single wall-mounted, rotary speed-control switch, Figure 8, located in the food preparation area (to the right of the spice rack). Rotating the control knob clockwise turns on and increases the speed of both fans. Rotating the knob fully counter-clockwise turns off the fans.

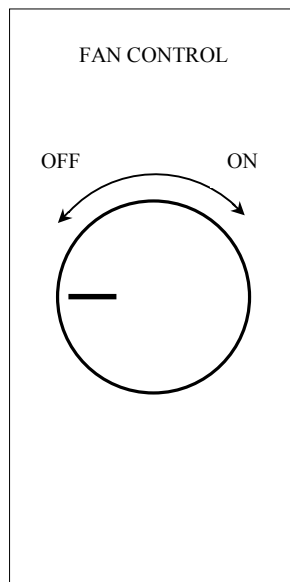

Figure 8. Cook Center Ventilation Control Switch.

**CONTAINERIZED KITCHEN (WITH TRAILER)
DESCRIPTION OF OPERATOR CONTROLS AND INDICATORS**

Mobile Warming Cabinet

The controls and indicators for the mobile warming cabinet (Figure 9) are located at the bottom front of the unit and include the following:

- Power switch (1): ON/OFF rocker switch turns the cabinet on and off.
- Temperature control knob (2): Adjusts cabinet temperature setting.
- Digital thermometer (3): Shows cabinet temperature (°F)
- Yellow indicator lamp (4): Lights when the heating element is on.
- Red indicator lamp (5): Lights when the power is on.

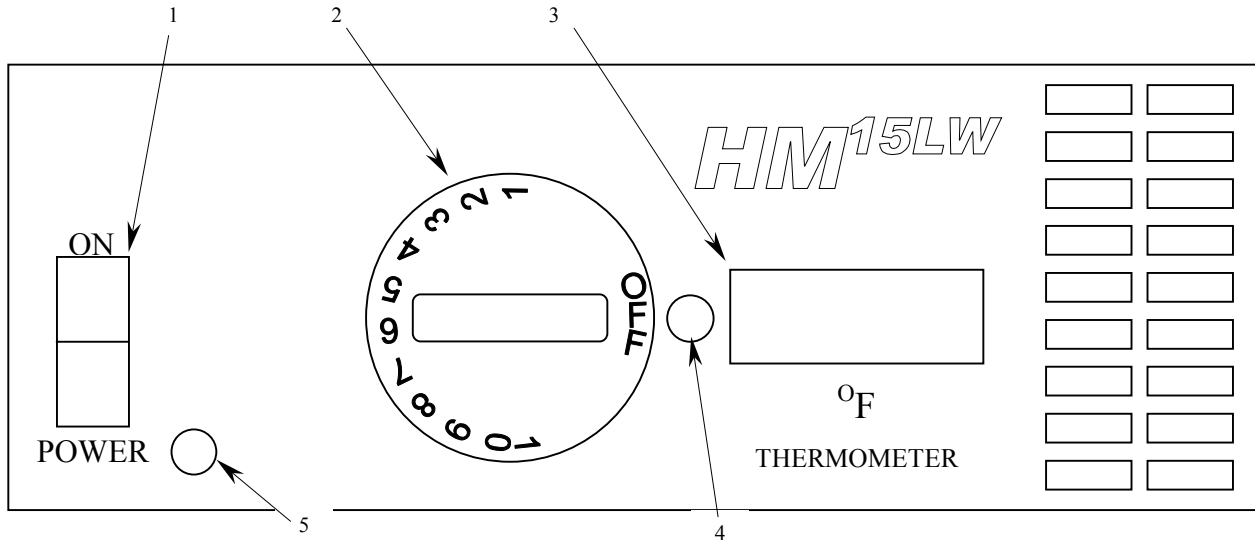

Figure 9. Mobile Warming Cabinet Controls.

Refrigerators

Each refrigerator is controlled by a thermostat (Figure 10) located on the inside back wall of the unit. Rotating the knob clockwise lowers the temperature setting (makes the refrigerator colder). Rotating it fully counter-clockwise to OFF shuts off the unit. A small glass thermometer on the side wall of each unit shows the temperature in °F.

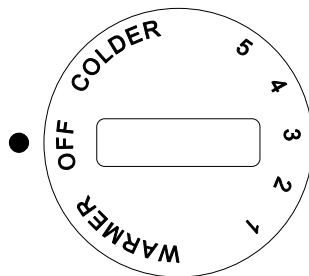

Figure 10. Refrigerator Thermostat Control.

Environmental Control Unit (ECU)

The ECU is controlled by a wall-mounted, four-position rotary switch (Figure 11) located to the right of the spice rack in the food preparation area. The switch positions are:

CONTAINERIZED KITCHEN (WITH TRAILER)**DESCRIPTION OF OPERATOR CONTROLS AND INDICATORS**

- HIGH COOL – Both air conditioners operate continuously. Compressors cycle depending upon available electrical power.
- LOW COOL – One air conditioner operates continuously.
- OFF – Environmental Control Unit is not operating.
- HEAT – Heater and one air conditioner fan operate continuously.

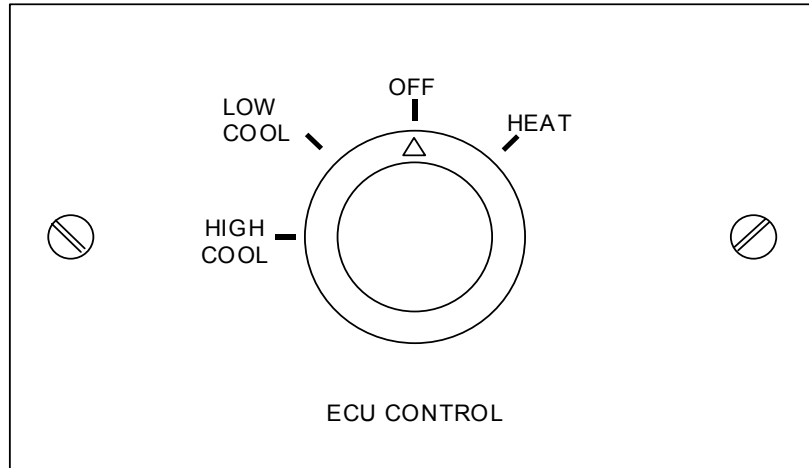

Figure 11. ECU Control Switch.

Oven

The oven controls, Figure 12, are located on the front of the oven. They consist of:

- Fan switch (1): ON/OFF toggle switch for the oven exhaust fan.
- 60-minute timer (2) and 5-hour timer (3): Mechanical timers for setting cooking time. Rotate the knob clockwise to set the desired time. A bell rings when the set time has elapsed. The timers are for convenience only; they do not control the oven.
- Fan switch (4): Three-position toggle switch (FAN HIGH/OFF/FAN LOW) for the oven's two-speed internal convection fan.
- Indicator light (5): Lit when the oven's internal convection fan is running.

**CONTAINERIZED KITCHEN (WITH TRAILER)
DESCRIPTION OF OPERATOR CONTROLS AND INDICATORS**

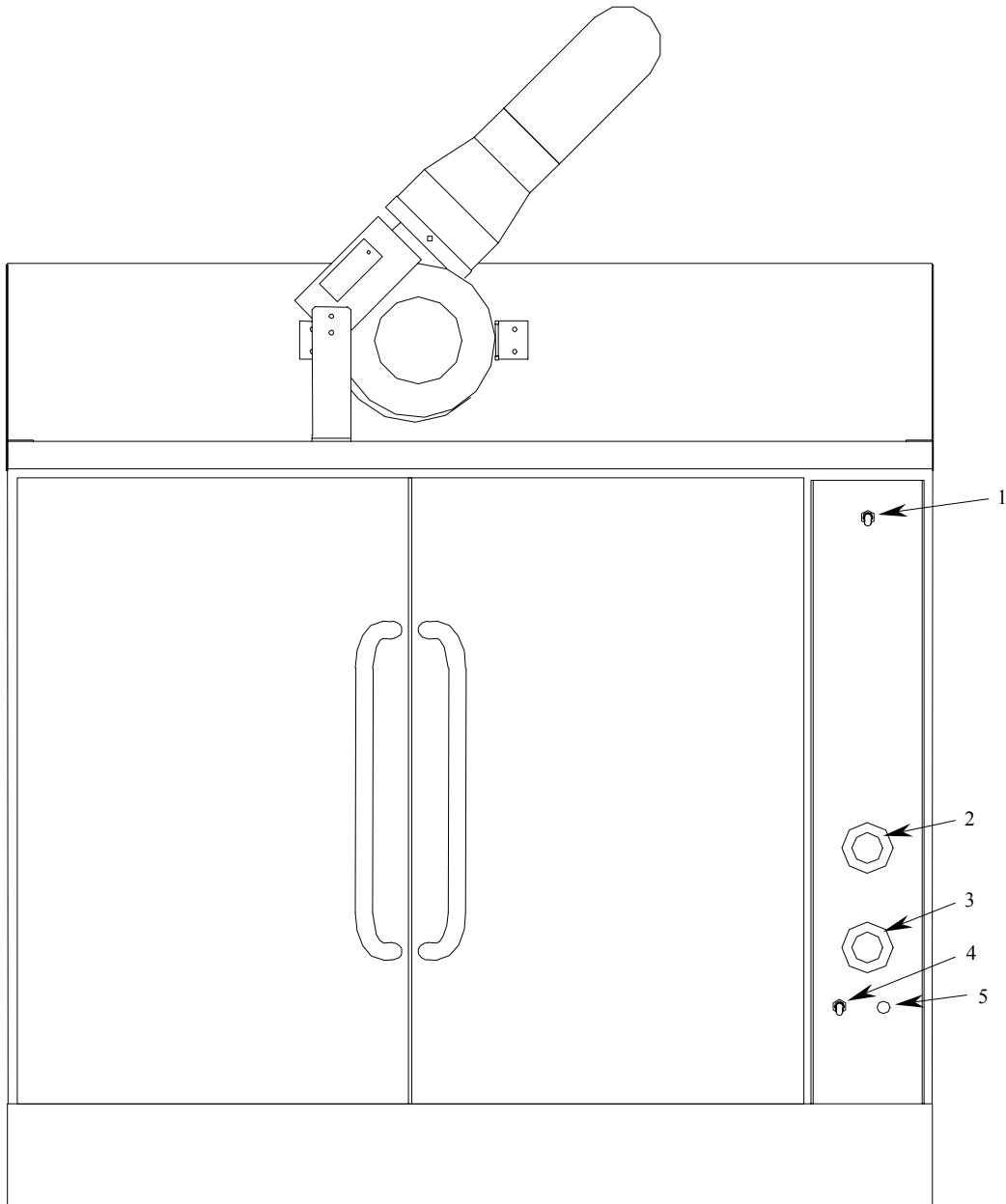

■ Figure 12. Oven Controls.

**CONTAINERIZED KITCHEN (WITH TRAILER)
OPERATION UNDER USUAL CONDITIONS**

INITIAL SETUP:

CK packed out

Maintenance Level

Operator/Crew

Personnel Required

Four (plus one supervisor)

GENERAL

When the CK arrives at the deployment site, all equipment necessary for setup and operation is packed inside the container. This work package provides step-by-step instructions for siting, leveling and expanding the container, erecting the shelter, and configuring the CK for meal preparation under usual operating conditions. Except as noted, all steps must be performed in the order given.

SITE REQUIREMENTS

1. If the CK is mounted on a trailer, the selected site must have a minimum of 50 ft x 30 ft of level, open space to provide maneuvering room for the tow vehicle and trailer.
2. The site must be level to a maximum elevation difference of 6 inches in 10 feet. If in doubt, consult the Operations Supervisor or Unit Commander.
3. The terrain must be firm, well drained, and relatively free of surface rocks and stones. If the soil at the site is not dry and well packed, dunnage or other support materials must be placed under the jack base plates to prevent them from sinking.
4. The slope of the terrain must not exceed 18 inches over the projected floor area of the expanded shelter (approximately 20 ft x 22 ft). If in doubt, consult the Operations Supervisor or Unit Commander.
5. If there are prevailing winds, the CK should be oriented so that exhaust gases from the onboard generator will not blow into the shelter or be drawn into the ventilation system.
6. If external electrical power will be used, the CK must be positioned within reach of the available power cable. If possible, the cable should be routed away from personnel and vehicular traffic paths. If the cable must be routed across a road or other potential vehicle path, it must be protected from damage.
7. Depending upon the makeup of the operating crew, a step aid may be required to perform some setup procedures.

ASSEMBLY AND PREPARATION FOR USE

1. With the tow vehicle, position the trailer in the desired location. Refer to "Site Requirements", earlier.
2. Refer to TM 9-2330-328-14&P for procedures to retrieve, install and operate the trailer leveling jacks, and to disconnect the trailer from the tow vehicle.
3. Disconnect the tow vehicle and move it out of the way before leveling the trailer.

**CONTAINERIZED KITCHEN (WITH TRAILER)
OPERATION UNDER USUAL CONDITIONS**

Unpacking the Mechanical Room

Before beginning to set up the CK, unpack the mechanical room as described below. The room is at the end of the container with the double doors. As items are removed, place them in convenient locations away from the sides of the CK and out of the way of personnel. Items not removed in the following steps can be left in the mechanical room until called for later in this work package.

1. Unlatch and open both mechanical room doors.
2. If the CK is on the trailer, one person shall climb into the mechanical room to assist in removing items.
3. Unstrap and remove the 8 wing jacks from on top of the stair/ladders. Store the rubber straps in any convenient location in the mechanical room.
4. With one person holding the stair/ladders to prevent them from shifting, loosen the two ratchet straps and remove the ground rod slide hammer from on top of the stair/ladders.
5. Remove the 6 water cans from between the stair/ladder treads.
6. Remove the 3 stair/ladders.
7. Remove the platform and platform rail. These are located to the left of the generator.
8. Store the ratchet straps in any convenient location in the mechanical room.

Shelter Deployment

The CK may be mounted on its trailer or placed on the ground. Figure 1 shows the three types of jack assemblies used for deployment. If the CK is on a trailer, only the wing jacks are used. For ground deployment, all three types of jacks are used.

Leveling the Container on the Ground**WARNING**

Read and understand all instructions in the following paragraphs before installing or operating the jacks. Personal injury and/or equipment damage can occur if the jacks are improperly installed or operated.

Be careful when installing the jacks. Never allow anyone or any part of your body to be under any portion of the jacks or the container.

The corner and screw jacks are designed for use only with the CK. Do not use them to support or level any other container.

1. Retrieve the two corner jack bodies, two screw jack bodies, and the two corner jack extension/base plates from their storage brackets on the left mechanical room door. The wing jacks should have already been removed when the mechanical room was unpacked.
2. Retrieve the two screw jack extension/base plates from their storage location to the left of the generator.
3. Open the personnel door. Unstrap and remove the stair/ladder railings packed just inside. Temporarily place them in a convenient location.

CONTAINERIZED KITCHEN (WITH TRAILER) OPERATION UNDER USUAL CONDITIONS

- Retrieve the jack/winch handles from their storage location on the side of the rifle rack, to the left just inside the personnel door.

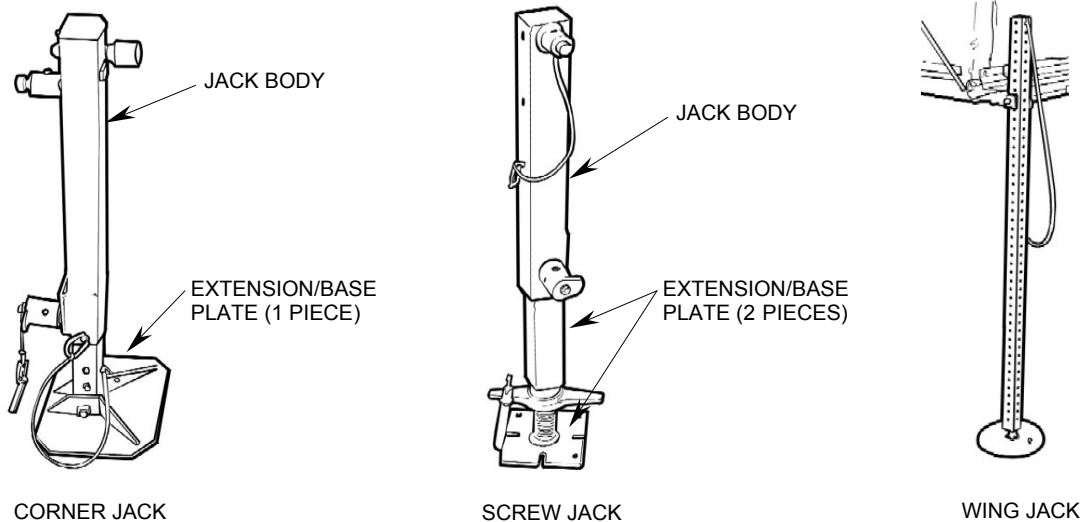

Figure 1. CK Jacks.

- Referring to Figure 2, insert a corner jack extension/base plate into each corner jack body as far as it will go. Align the bottom hole in the extension/base plate with the hole in the jack body and insert the attached locking pin to hold the extension/base plate in place. Using a jack/winch handle, ensure that the jack mechanisms are rotated fully counter-clockwise (lowered).
- In a similar manner, assemble the two screw jacks, ensuring that the adjustment screws are fully clockwise (lowered).
- The corner jacks will first be installed at the personnel door end of the container. Referring to Figure 2, and starting at either corner, attach a corner jack by inserting the studs on the jack into the end holes in the corner block. Turn the twist lock on the lower stud 90° in either direction to line up one of the arrows stamped on it with the hole in the stud. Pull the jack back slightly so the twist lock contacts the inside of the corner block. Insert the attached locking pin into the twist lock.
- Repeat step 7 for the other corner jack. Ensure that the twist locks are engaged, all locking pins are in place, and the jacks are resting parallel to the corner blocks.
- Locate the bullseye level mounted on the end of the container in a recess in the corner block, to the left of the personnel access door. Figure 3 shows typical bubble level indications and what they mean.

**CONTAINERIZED KITCHEN (WITH TRAILER)
OPERATION UNDER USUAL CONDITIONS**

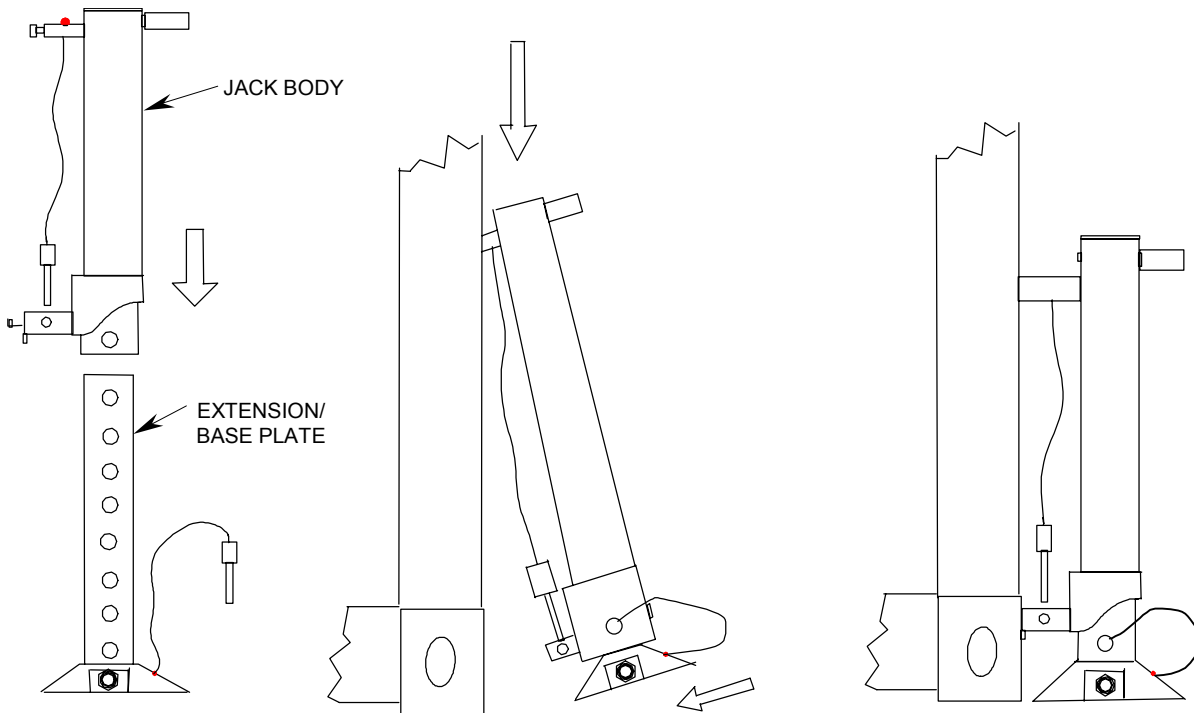

Figure 2. Corner Jack Installation.

CAUTION

When raising the container, the two corner jacks MUST be operated together. Raising one jack alone can result in damage to the jacks.

10. Simultaneously rotate the two jack handles clockwise and raise the end of the container until it is slightly higher than the opposite end. Observing the bullseye level, separately adjust the rotation rate of the jacks as necessary to level the end of the container from side to side.
11. Install the two screw jacks next to the corner jacks, in the holes on the side of the corner blocks. Raise the screw jacks until the operating screw is tight (cannot be turned by hand). Remove the corner jacks.
12. Repeating step 7 above, install the corner jacks at the opposite end of the container. Simultaneously rotate the two jack handles clockwise to raise the container. Observing the bullseye level mounted in a recess to the left of the mechanical room doors, separately adjust the rotation rate of the jacks as necessary to level the end of the container from side to side. Once the end is level, raise both corners together until the container is level from end to end.
13. Return the jack/winch handles to their storage locations on the side of the rifle rack. Strap them in place with their handle ends up.

CONTAINERIZED KITCHEN (WITH TRAILER) OPERATION UNDER USUAL CONDITIONS

Leveling the Container on the Trailer

1. Locate the two bullseye levels mounted on the ends of the container, in recesses in the corner blocks. One is to the left of the personnel access door, and the other is at the opposite end, to the left of the mechanical room doors. Using the levels, identify the high end of the container (personnel door end or mechanical room end). Figure 3 below shows typical level indications and what they mean.

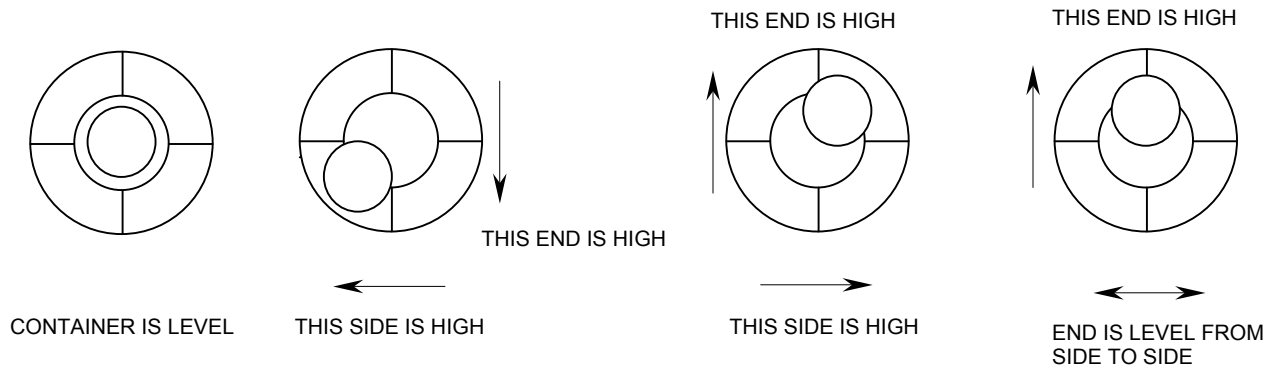

Figure 3. Bubble Level Indications.

2. At the high end, rotate the two jack handles of the trailer leveling jacks clockwise, separately adjusting the rotation rate of the jacks as necessary until the end is level from side to side.
3. Moving to the opposite (low) end, raise both corners simultaneously, adjusting jack rotation speed as necessary to level that end from side to side.
4. Continue raising the low end until the container is level from end to end.

Shelter Expansion

1. If not already done, open the personnel door and retrieve one of the jack/winch handles from its storage location on the side of the rifle rack.

WARNING

The orange safety straps MUST be in place before unlocking the cam-locks on the sides of the container. The straps are visible even when the wings are closed.

2. Verify that the orange safety strap is attached to the serving wing (the right side when viewed from the end containing the personnel door). Climb onto the roof of the container and attach the strap if it is not (if the CK is on the ground, it will not be necessary to climb onto the roof to attach the strap). Figure 4 shows where the safety strap is located on the serving wing. It is in the same location on the food preparation wing.
3. Place three wing jacks at each wing (each corner and middle of the wing). Place the jacks approximately 8 feet out from the sides of the container.

CONTAINERIZED KITCHEN (WITH TRAILER) OPERATION UNDER USUAL CONDITIONS

4. Insert the winch handle into the right winch drive slot and crank clockwise until the cable is free of slack (the winch handle becomes harder to turn). See Figure 4.

WARNING

When raising or lowering the wings, one member of the crew must act as a spotter to ensure that all personnel stay clear.

5. Crank approximately two turns counter-clockwise to release tension on the cable.
6. Turn the four cam-lock handles about 45° to partially unlock them.
7. Crank approximately 2 more turns counter-clockwise, then turn the cam-lock handles until they are at 90° (pointing straight out from the wing).

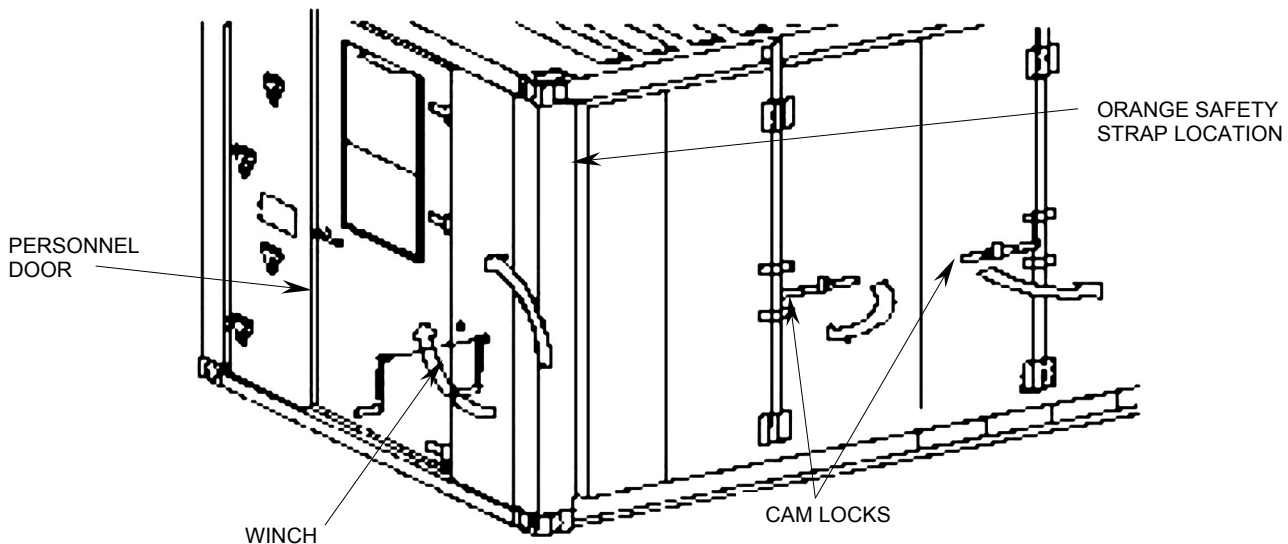

Figure 4. Shelter Expansion.

8. Crank counter-clockwise until the top of the wing is about 6 inches away from the top edge of the container.
9. Stop cranking and secure the cam-lock handles to their holders.
10. Climb onto the roof of the container and unhook the orange safety strap from the wing (if the CK is on the ground, the strap can be unhooked without climbing onto the roof).
11. Continue lowering the wing until it is level as indicated by the bubble levels attached to the edges of the wing. If the winch cable binds slightly, the wing will stop lowering and the winch handle will become easier to turn. If this happens, crank the winch in the clockwise direction for a few turns and then resume lowering the wing. Repeat this process as necessary until the wing is lowered.

CONTAINERIZED KITCHEN (WITH TRAILER) OPERATION UNDER USUAL CONDITIONS

CAUTION

Do not move loads onto the wing until the wing jacks are installed.

12. Adjust each wing jack by screwing its base completely in. Align a set of holes in the jack with the bracket on the wing. Insert the locking pin through the bracket and jack. Screw the base down until it is firmly in contact with the ground.
13. Crank counter-clockwise approximately half a turn or until the weight of the wing is supported by the jacks.
14. If the CK is mounted on a trailer, install the stair/ladders and handrails at the serving wing doors. Ensure the steps rest firmly on the ground.
15. Repeat steps 2 through 13 for the food preparation wing (use the left winch drive slot). It is not necessary to climb onto the roof to unhook the orange safety strap on this wing. The strap can be reached by climbing on the fold-down steps on the end of the container.
16. Return the winch handle to its storage location on the side of the rifle rack. Strap it in place with its handle end up.

Fabric Erection – Serving Wing

WARNING

The bags containing the shelter arch frame components weigh approximately 130 lbs (59 kg) each. Three persons must carry the bags, lifting with legs, not back, to prevent injury.

1. Open the serving wing entrance door nearest the personnel door. Enter the serving wing, locate and retrieve the two arch frame bags.
2. Figure 5 and Table 1 below identify the frame components and the quantity of each. Unzip the bags as necessary to locate the bag containing the two curved spacers.

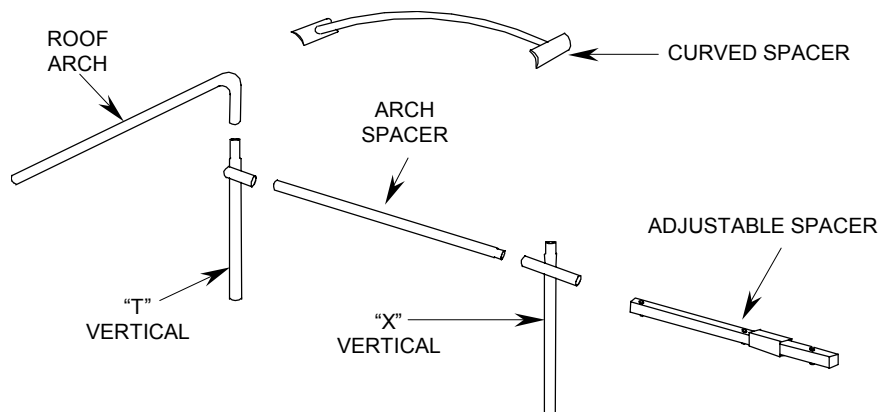

Figure 5. Shelter Frame Components.

**CONTAINERIZED KITCHEN (WITH TRAILER)
OPERATION UNDER USUAL CONDITIONS**

Table 1. Contents of Shelter Frame Bags.

Component	Qty
Roof Arch	5
“T” vertical (left side)	1
“T” vertical (right side)	1
“X” vertical	3
Arch Spacer	3 (prep side) 2 (serving side)
Adjustable spacer (2 sections)	1 (prep side)
Curved spacer (used over serving wing doors)	2

NOTE

The wing floor must be level with the center core floor to ensure a correct fit for the roof arches.

3. Assemble a roof arch and an “X” vertical as shown in Figure 6.

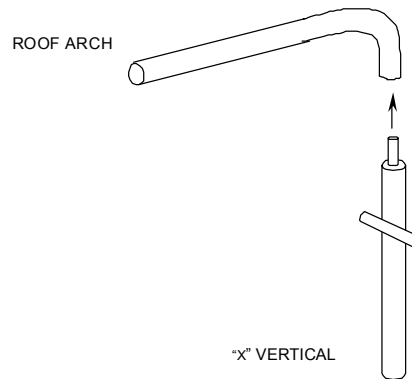

Figure 6. Center Arch Frame.

4. Position one or more personnel in the middle of the wing to push up the fabric cover and support it by hand.
5. Move onto the wing while holding the arch frame assembly.

NOTE

The horizontal stubs on the verticals must face toward the inside.

6. Starting with the center interior arch location, with other personnel supporting the fabric, rotate the arch frame assembly to insert the upper end of the arch into the arch cup at the header, as shown in Figure 7.

**CONTAINERIZED KITCHEN (WITH TRAILER)
OPERATION UNDER USUAL CONDITIONS**

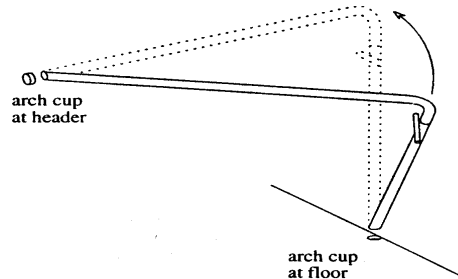

Figure 7. Arch Frame Inserted into Arch Cups.

7. Pushing lightly on the end of the assembly to hold it in the header cup, swing the assembly (keeping corner below fabric cover) until the vertical bottom end is inserted into arch cup in the floor.

WARNING

Until the arch spacers are installed, the roof arches may fall.

8. Rotate the assembly into vertical position. Some force is required once the arch contacts the fabric. Other personnel may release the fabric to help. Once in place, release the arch.
9. Repeat steps 6 through 8 for the other two central cup locations with roof arch/"X" vertical assemblies.
10. Repeat steps 6 through 8 for the two corner locations using a roof arch and a "T" vertical.

NOTE

The stubs on the verticals must face toward the inside.

11. Install arch spacers, as shown in Figure 8, between the center arch and its two adjacent arches. Slide an arch away then back to push the stub inside the spacer.

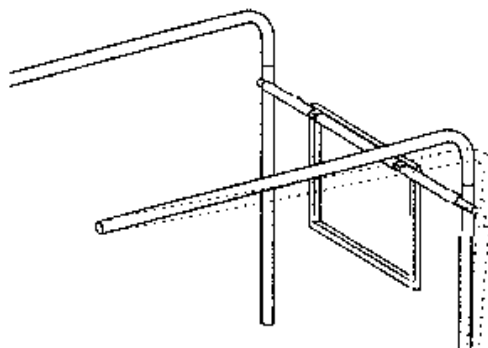

Figure 8. Arch Spacer Installation.

**CONTAINERIZED KITCHEN (WITH TRAILER)
OPERATION UNDER USUAL CONDITIONS**

12. Install a curved spacer, as shown in Figure 9, over each serving wing door. Place one end of the spacer near the down-turn of the roof arch and lift up the other end against the fabric. Force the roof fabric up until the end of the spacer fits over the next arch. Position the spacers approximately 2 feet in from the doors. If desired, the doors can be held open by folding them up and wedging them between the fabric and the curved spacers.

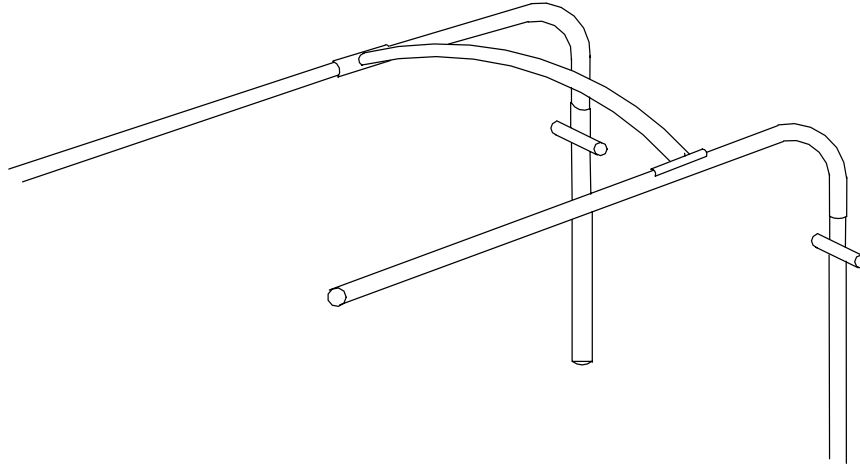

Figure 9. Doorway Support Installation.

**CONTAINERIZED KITCHEN (WITH TRAILER)
OPERATION UNDER USUAL CONDITIONS**

Fabric Erection – Food Preparation Wing**NOTE**

The wing floor must be level with the center core floor to ensure a correct fit for the roof arches.

1. Unstrap the two refrigerators, unlock their casters, and move them into the serving wing to allow access to the food preparation wing. When moving a refrigerator, grasp the metal bracket on the back. Do not pull on the tube on the back of each unit.
2. Assemble a roof arch and an "X" vertical as shown in Figure 6.
3. Position one or more personnel in the middle of wing to push up the fabric cover and support it by hand.
4. Move onto the wing while holding the arch frame assembly.

NOTE

The stubs on the verticals must face toward the inside.

5. Starting with the center interior arch location, with other personnel supporting the fabric, rotate the arch frame assembly to insert the upper end of the arch into the arch cup at the header, as shown in Figure 7.
6. Pushing lightly on the end of the assembly to hold it in the header cup, swing the assembly (keeping corner below fabric cover) until the vertical bottom end is inserted into the arch cup at the floor.
7. Rotate the assembly into vertical position. Some force is required once the arch contacts the fabric. Other personnel may release the fabric to help. Once in place, release the arch.
8. Repeat steps 5 through 7 for the other two central cup locations with roof arch/"X" vertical assemblies.
9. Repeat steps 5 through 7 for the two corner locations using a roof arch and a "T" vertical.
10. Starting at the corner nearest the mechanical room, install two arch spacers, as shown in Figure 8, between the first two sets of adjacent arches. Slide an arch away then back to push stub inside spacer.
11. At the opposite corner, install an arch spacer between the first two arches.

WARNING

Be careful not to pinch your fingers while installing the adjustable spacer.

12. Install the adjustable spacer, as shown in Figure 10, in the remaining location. Slide the adjustable spacer between the stubs of the verticals. To obtain the correct tension, adjust the length by moving the bolt to the desired location. Orient the spacer so that it will tighten by pushing outward. Two personnel may be needed to straighten the spacer.
13. Apply tension to the spacer by pushing it outward to straighten. Slide the sliding tube to lock.

**CONTAINERIZED KITCHEN (WITH TRAILER)
OPERATION UNDER USUAL CONDITIONS**

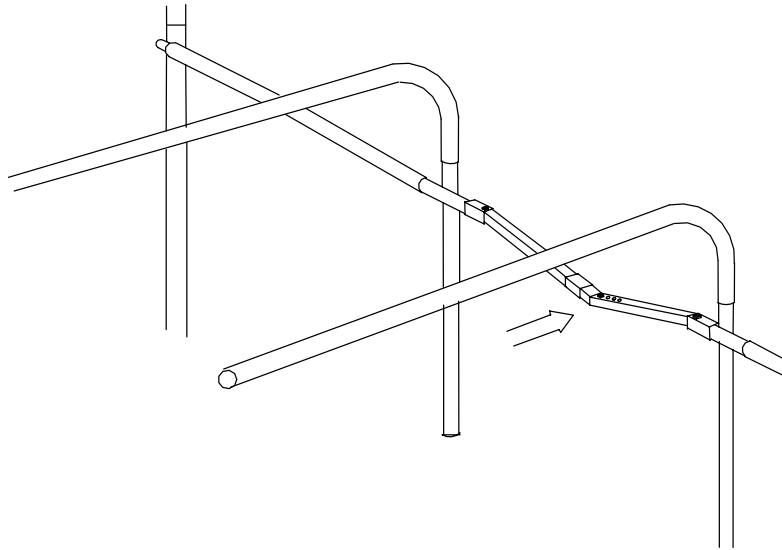

Figure 10. Adjustable Spacer.

Mechanical Room Setup

1. If the CK is mounted on a trailer, install the platform to provide a safe standing area for setting up the mechanical room. Hook one edge of the platform to the bracket on the end of the container and support the other edge with two wing jacks.
2. Unfurl the cloth discharge ducts for the generator, exhaust fan, and air conditioner. They should already be attached to the components via hook and loop tape at one end. Attach them if they are not.
3. Retrieve the awning from its storage location on top of the generator. Referring to Figure 11, attach the awning by screwing the four thumbscrews into the threaded holes along the top jamb of the mechanical room door frame.

CONTAINERIZED KITCHEN (WITH TRAILER) OPERATION UNDER USUAL CONDITIONS

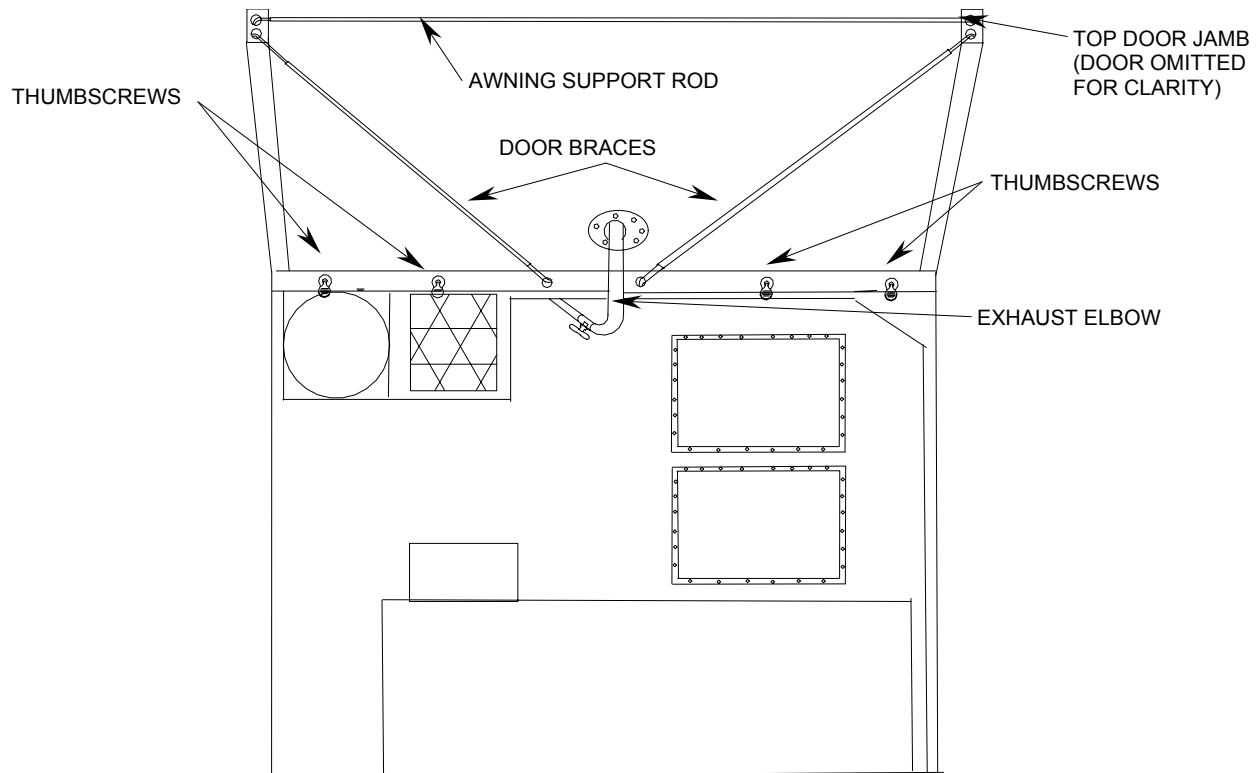

Figure 11. Awning Installation.

4. Retrieve the generator exhaust elbow pipe from its storage location to the right of the generator. Insert the open end of the pipe down through the opening in the awning from the top side. Attach the elbow pipe to the fixed exhaust pipe using the clamp coupler provided. Ensure the outlet end of the elbow pipe is pointing straight upward.
5. Retrieve the two door braces from their storage location on the floor under the air conditioners. Place the S-shaped end of one brace through one of the center two grommets in the awning and into the corresponding hole in the top door jamb.
6. Place the other end of the brace in the inner hole in the bracket on the door. The other of the two holes holds the awning support rod.
7. Repeat the previous two steps for the other door brace.
8. Retrieve the long awning support rod from its storage location on the floor. Slip the rod through the long loop on the underside of the outboard end of the awning and place the ends of the rod in the outer holes of the brackets on the doors.
9. Pull the edge of the awning over the awning support rod and buckle the straps (not shown) to the mating buckles attached to the doors.
10. Hang the ends of the three cloth discharge ducts to the door braces using the attached straps.

**CONTAINERIZED KITCHEN (WITH TRAILER)
OPERATION UNDER USUAL CONDITIONS**

11. Locate the ends of the two clear plastic air conditioner condensation drain hoses. Position them so the condensation drains outside of the mechanical room.
12. Retrieve the MBU fuel can adapter from its storage location to the left of the generator and install it on a filled fuel can. Place this can between the two tie-down provisions in the floor on the left side of the mechanical room. Strap the can down with one short rubber strap. Ensure the vent valve on the fuel can adapter is open.
13. Connect the hose from the fuel can adapter to the fuel connection on the left wall, underneath the Power Entrance Panel.
14. Place a second filled fuel can on the ground outside of the mechanical room.
15. Uncoil the generator's auxiliary fuel line from its storage location to the left of the generator and connect it to the fuel can adapter.

NOTE

The normal method of fueling the generator is by a fuel can connected to the auxiliary fuel line as described in the preceding steps. However, it can also be manually refueled through an access door in the serving wing, to the left of the Power Distribution Panel.

16. If the platform was installed outside the mechanical room in step 1, remove the platform and the two wing jacks.

Platform Installation

If the CK is on the trailer, install the platform at the personnel door as follows:

1. Close the personnel door.
2. Hook the edge of the platform over the bracket under the door and rest the platform on the trailer tongue.
3. Attach the two wing jacks to the platform.
4. Install the platform rail.
5. Install the stair/ladder and stair rail.
6. If desired, open the personnel door and hold it open using a short rubber strap.

Grounding

If the CK is to be energized from the onboard generator, the ground rod must be installed and the ground cable connected as described below. If the CK is to be energized from external power, it will be automatically grounded through the power source, and the following steps need not be performed.

1. Remove the ground rod from its storage location next to the Power Entrance Panel inside the mechanical room.
2. Using the slide hammer (WP 0049 00, Table 2, Item 29), drive the ground rod at least 8 feet into the earth at a suitable location that is near enough for the grounding cable to reach from the rod to the grounding terminal on the Power Entrance Panel (the cable is approximately 8 feet long).
3. Connect one end of the grounding cable to the ground rod using the clamp provided. Ensure that the connection is tight.

**CONTAINERIZED KITCHEN (WITH TRAILER)
OPERATION UNDER USUAL CONDITIONS**

4. Connect the other end of the grounding cable to the grounding terminal on the Power Entrance Panel. Ensure that the connection is tight.

Energizing the CK from the Onboard Generator

The following procedures should be followed to properly and safely supply power to the kitchen from the generator. While the generator is capable of taking the full load of the kitchen appliances and utilities all at once, it is not recommended that all loads be turned on at the same time. The following procedures allow the kitchen to be brought on line safely and effectively. Except as noted, the applicable controls and indicators are located on the Main Control Panel, shown in Figure 12.

CAUTION

If appliances have been moved into position before energizing the onboard generator, ensure that the switches for the water pump and water heater are left OFF until the water system and water heater are filled. Energizing these components without water in them will result in equipment damage. Also turn off the lights, exhaust fans, and oven fans. The refrigerators may be plugged in and turned on, and the Environmental Control Unit (ECU) has a built in time delay and may be left on.

1. From the generator control panel, start the generator and close its output contactor (AC Circuit Interrupter) in accordance with the procedures in TM 9-6115-642-10.

NOTE

If its battery is discharged, the generator can be started by connecting a 24 VDC power cable to the NATO slave receptacle on the side of the generator. Refer to TM 9-6115-642-10 for slave starting procedures.

On CK units with serial numbers CK000151 and higher, the slave receptacle is behind the generator access door in the wall of the food preparation area. On units with serial numbers CK000150 and lower, it is behind the access plate located next to the first aid kit (on these units, the right-angle NATO plug does not fit and cannot be used).

2. Verify that the amber GENERATOR POWER AVAILABLE indicator is lit.
3. If the EXTERNAL POWER ON indicator is lit, press the black System Power OFF button and verify that the light goes out. This ensures that the kitchen is de-energized before applying generator power.

CAUTION

Before applying generator power, ensure that the kitchen is properly grounded as described in "Grounding", above.

4. Press the GENERATOR POWER ON pushbutton and verify that it lights green.

CONTAINERIZED KITCHEN (WITH TRAILER) OPERATION UNDER USUAL CONDITIONS

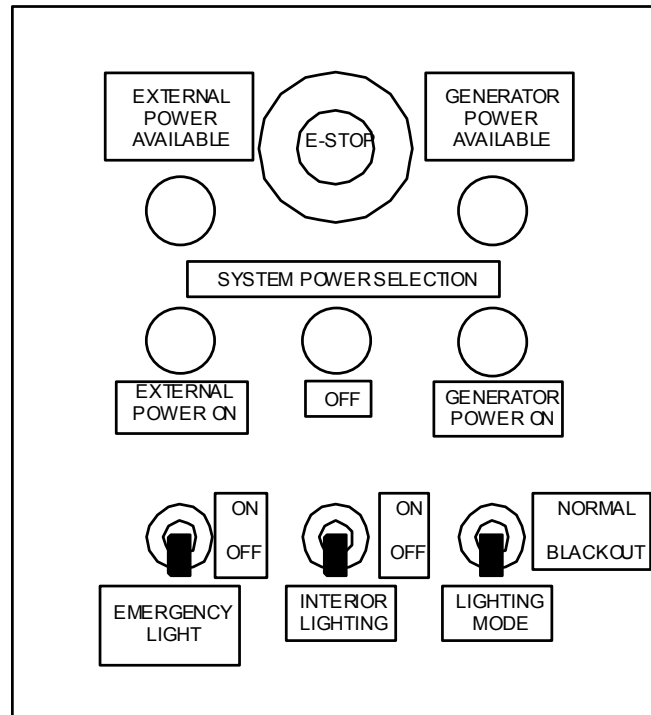

Figure 12. Main Control Panel.

- Turn the EMERGENCY LIGHT switch to ON to charge the emergency lighting battery. If desired, turn on the lights using the INTERIOR LIGHTING switch.
- Turn on the ECU and the cook center ventilation fans as desired. Their controls are located next to the spice rack. Position the ECU control switch to the desired operating mode.

Energizing the CK from External Power

The CK can be operated from an external 120/208 VAC, 60-amp, 3-phase power source. A cable from the external source must be provided. The cable should be attached to the receptacle on the Power Entrance Panel located on the left wall in the mechanical room.

CAUTION

If appliances have been moved into position before energizing external power, ensure that the switches for the water pump and water heater are left OFF until the water system and water heater are filled. Energizing these items without water in them will result in equipment damage.

- Turn off the water pump and water heater at the appliance control box unless the water system is charged and the water heater is full.

**CONTAINERIZED KITCHEN (WITH TRAILER)
OPERATION UNDER USUAL CONDITIONS**

WARNING

Do not attempt to connect an energized cable to the Power Entrance Panel.

2. Ensure that external power is turned off at its source, then connect the cable at the Power Entrance Panel.
3. Connect the opposite end of the cable to the source, if not already connected, and energize the source. Verify that the amber EXTERNAL POWER AVAILABLE indicator is lit.
4. If the GENERATOR POWER ON indicator is lit, press the System Power OFF pushbutton and verify that the light goes out. This ensures that the kitchen is de-energized before applying external power.
5. If it is running, shut down the generator as described in TM 9-6115-642-10.
6. Disconnect the ground cable from the ground terminal on the Power Entrance Panel.
7. Press the EXTERNAL POWER ON pushbutton and verify that it lights green.
8. Turn the EMERGENCY LIGHT switch to ON to charge the emergency lighting battery. If desired, turn on the lights using the INTERIOR LIGHTS switch.
9. Turn on the ECU and the cook center ventilation fans as desired. Their controls are located to the right of the spice rack. Position the ECU control switch to the desired operating mode.

Appliance and Equipment Relocation

The CK is shipped with most of its appliances and associated equipment tied down so that they are not damaged during shipment. These items must be relocated to their designated operating positions as described below. The refrigerators should have already been moved into the serving wing to allow access for erecting the food preparation wing shelter.

Before moving items with casters, ensure that the casters are unlocked.

After unstrapping and positioning the various items, store the straps on the hanger bars on the food preparation side wall of the mechanical room.

As the electrical appliances and lights are positioned in the following steps, they are plugged into designated outlets in the raceway located in the ceiling of the shelter core. These outlets are shown in Figure 13. If necessary, appliances and other items may be temporarily moved to reach the plugs.

CONTAINERIZED KITCHEN (WITH TRAILER) OPERATION UNDER USUAL CONDITIONS

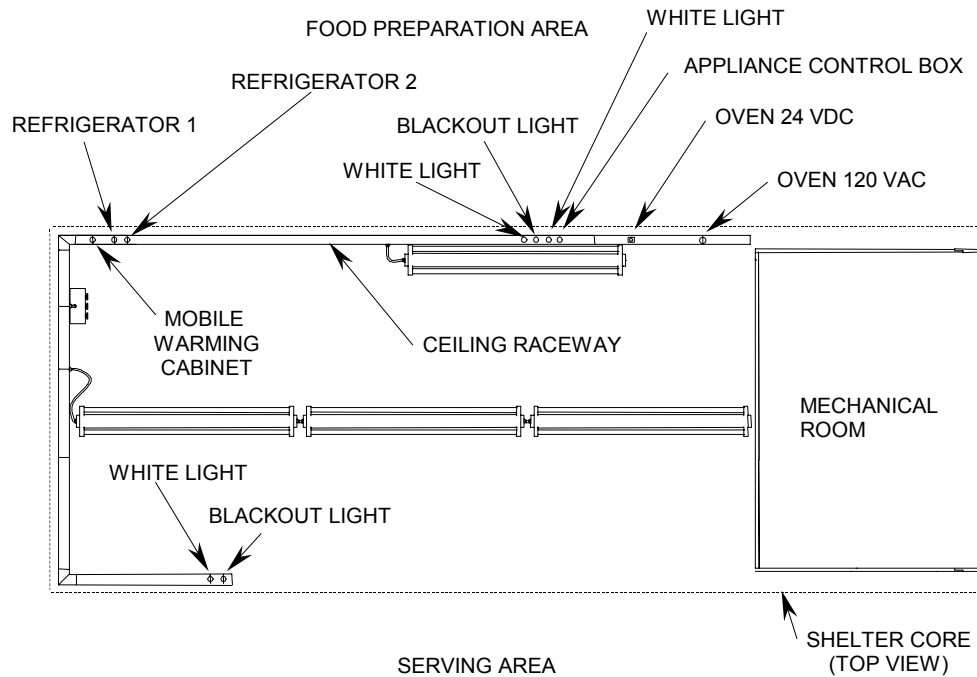

Figure 13. Ceiling Raceway Electrical Connections.

WARNING

Use caution when moving appliances and equipment in the following steps, to avoid pinching hands or fingers.

1. Unstrap the sink assembly and move it to approximately its operational position under the window nearest the personnel door in the food preparation wing.
2. Unstrap the two mobile storage cabinets and move them to the serving wing.
3. Remove the water supply and drain hoses from the lower shelf and back of the sink assembly.
4. At the back of the sink assembly, attach one end of the 15-foot internal drain hose to the sink drain and the other end to the fitting on the floor drain by the personnel door. Route the hose close to the walls.
5. Remove the dust cap from the exterior drain fitting at the base of the shelter, to the left of the personnel door. Attach the 50-foot external drain hose to the fitting. Attach the other end to the water collection facility.
6. From outside, feed the male end of the water supply hose through the smaller of the two penetrations below the window in the food preparation wing. Ensure that the hose washer on the sink fitting is in place. Connect the hose to the fitting. Connect the other end of the hose to the water source.
7. Uncoil the water heater and water pump power cables from the back of the sink assembly and temporarily drape them across the top of the assembly.

**CONTAINERIZED KITCHEN (WITH TRAILER)
OPERATION UNDER USUAL CONDITIONS**

8. Roll up the window flap behind the sink location and secure it with the strap provided.
9. Position the sink assembly in its operational position and lock the front casters.
10. If it will not be needed to fill the steam table or tray pack heater, repack the 25-ft water supply hose on the bottom shelf of the sink assembly.
11. Unstrap the mobile warming cabinet and move it to its operational position in the food preparation wing, against the positioning rail on the floor. Place it as tightly in the corner as possible and lock the front casters. Connect its power cord to the marked receptacle on the ceiling raceway in the center core of the kitchen.
12. Unstrap the pan rack and temporarily move it and the steam table pans to a convenient location out of the way.
13. Unstrap and move the oven assembly to approximately its operational location in the food preparation wing. Inside the oven, unstrap the work table drawers and retrieve the chimney pipe. Attach it to the outlet of the oven fan, oriented so the outlet points down. The drawers may be left inside the oven until they are called for later in this work package.
14. Carefully guiding the chimney pipe through the opening in the wall, locate the oven assembly against the positioning rail on the floor. Lock the front casters.
15. Uncoil the fuel line on right side of the oven assembly. Lead it along the floor against the end wall, remove the dust caps, and attach it to the fuel supply fitting at the base of the mechanical room wall.
16. Uncoil the longer of the two 24 VDC power cables on the left side of the oven assembly. Lead it up the arch and plug it into its marked receptacle on the ceiling raceway. Similarly, uncoil the 120 VAC power cable on top of the oven assembly, route it up the arch, and plug it into its marked receptacle on the ceiling raceway. Secure both cables in place using the hook and loop straps on the 24 VDC cable.

CAUTION

Check to be sure the MBU is properly installed in the oven base. The top of the MBU should be flush with the bottom of the oven, and the hinged flap above the MBU should be down.

17. Move the pan rack to its operational position to the right of the oven assembly.
18. Retrieve the appliance control box from its storage location in the sink base. Hang it from the horizontal spacer bar just to the right of the center arch. Lead the power cable up along the arch to its marked receptacle on the ceiling raceway. Plug in the cable and secure it in place by wedging it between the shelter arch and the fabric.
19. Verify that the four switches on the appliance control box are OFF. Plug the power cables for the water pump (short cable) and water heater (long cable) into their respective outlets on the bottom of the box.

CAUTION

Ensure that no power cables are touching the tray pack heater or the oven. They could become damaged and result in a fire or shock hazard.

20. Secure the excess lengths of cable between the fabric and the spacer bar.

**CONTAINERIZED KITCHEN (WITH TRAILER)
OPERATION UNDER USUAL CONDITIONS**

21. Unstrap and remove the burner rack and base rack from on top of the tray pack heater. Place them in a convenient location in the serving wing.
22. Roll up the window flap next to the oven assembly and fasten it in place with the strap provided.
23. Unstrap and move the tray pack heater to near its operational location next to the oven assembly.
24. Remove the heater fan assembly from inside the tray pack heater and mount it in its bracket on the back of the unit. Route the exhaust pipe through its penetration in the shelter wall, orienting the pipe so its outlet points downward.
25. Attach the fuel line and power cable at the left of the oven to the MBU in the tray pack heater. Plug the heater fan cable into either of its designated outlets on the appliance control box.
26. Position the tray pack heater next to the oven assembly and against the positioning rail on the floor, and lock the front casters.

CAUTION

When moving a refrigerator, use the metal bracket on the back for a handhold. Do not grasp the plastic tube running down the back of the unit or it may be damaged.

27. Move the right-hand-hinged refrigerator to its operational location next to the mobile warming cabinet, leaving about a 4-inch space between them. Position the refrigerator against the positioning rail on the floor and lock the front casters. Connect its power cord to the Refrigerator No. 1 receptacle on the ceiling raceway.
28. Position the left-hand-hinged refrigerator near its operational location next to the other refrigerator and connect its power cord to the Refrigerator No. 2 receptacle on the ceiling raceway. After it is plugged in, line up the refrigerator so that the fronts of the two units are even with each other. Lock the front casters.
29. Remove the ratchet strap from the right half of the cook center. Remove the three insulated food transporters and store them in any convenient location.
30. Remove the ratchet strap from the left half of the cook center. Remove the two insulated food transporters and the beverage dispenser and store them in any convenient location.

WARNING

The packed light storage box weighs approximately 100 lbs (45.4 kg). Three persons must carry the box, lifting with legs not back, to prevent injury.

31. Remove the light storage box from on top of the cook center and place it in any convenient location on the floor of the serving wing.

NOTE

The two tables used in the food preparation area receive utility drawers, the two used in the serving area do not. All four tables have the drawer mounting hardware and are interchangeable.

**CONTAINERIZED KITCHEN (WITH TRAILER)
OPERATION UNDER USUAL CONDITIONS**

32. Remove the two tables from the left side of the cook center, unfold their legs, and place them in the serving wing. Position them against the sidewall between the doors. Store the burner rack and base rack under the tables.
33. Remove the four cook pot cradle adapters stored in the blanket from the cook center and store them under the tables. Remove the blanket and set it aside in a convenient location.
34. Remove the remaining two tables from the cook center, unfold their legs, and place them in the center of the food preparation wing. They may be placed in any convenient position as desired.
35. Retrieve the two drawer assemblies from their storage location inside the oven. After removing them, verify that the metal guard over the convection fan in the back wall of the oven is properly in place (it can come loose during transit).
36. Laying the tables on their tops, attach a drawer to each table in the preparation wing by screwing the captive screws on the drawer slides into the fittings on the table. Place the utensils in the drawers as desired. Store the remaining miscellaneous kitchen items as desired. Some of the knives may already be stored in the knife rack on the side of the sink assembly.
37. Position the mobile storage cabinets against either wall of the serving area as desired.

CAUTION

Do not place filled beverage dispensers or other heavy items in the mobile storage cabinets. Damage to the cabinets will result.

38. Remove the insulated food transporters from the refrigerators and mobile warming cabinet and store them in any convenient location. Place the spare tray slides back inside the mobile warming cabinet.

NOTE

The griddle, steam table, and cook pot cradle adapters are interchangeable and can be used on either half of the cook center peninsula.

39. Set up the cook center with the griddle and splash guards, the steam table and adapter top, or the cook pot cradle adapters and cook pot cradles, as desired. Any of these items can be set up on either half of the cook center. If the griddle is used, the splash guards must be retrieved from the light storage box and installed on the griddle. The back (longest) splash guard must be installed first.
40. Retrieve any loose tie-down straps and store them on the hanger bars on the wall in the food preparation area.

Ceiling Light Installation**WARNING**

In case of lamp breakage, be careful in removing glass fragments and white phosphorous dust that may be dispersed from the fixture. Handling glass fragments or inhaling phosphorous dust could cause personal injury.

1. Unpack the removable light fixtures from their storage box and position them as shown in Figure 14. Install the lights by slipping the hooked brackets at the ends of the fixtures between

CONTAINERIZED KITCHEN (WITH TRAILER) OPERATION UNDER USUAL CONDITIONS

the fabric and the arches. Orient each fixture so the end with the power cord is toward the designated receptacle.

2. Plug the power cords into their marked receptacles on the ceiling raceway.
3. Tuck the excess cable between the fabric and the arches.
4. Place the two arch frame component bags and the packing blanket in the light storage box. Store the box under the tables in the serving wing or in another convenient location as desired.

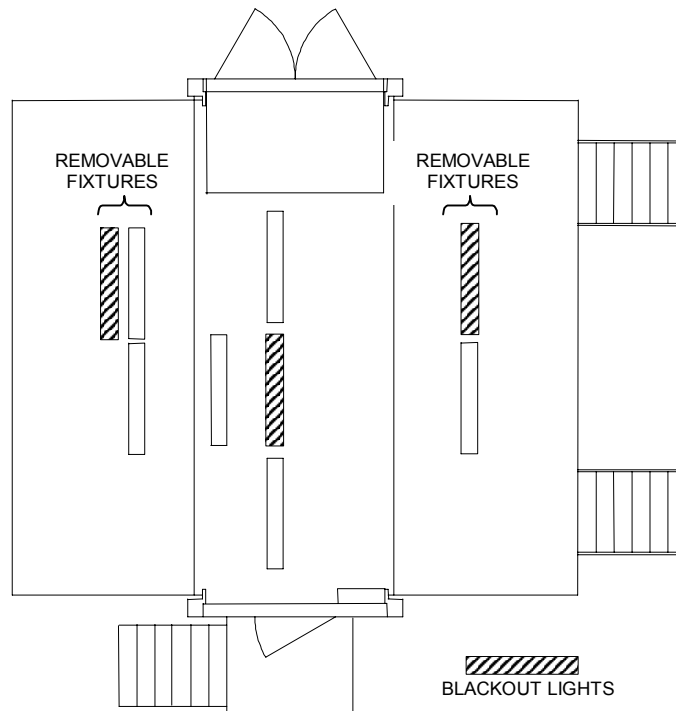

Figure 14. Ceiling Light Fixture Layout.

Water and Drain System Startup

The water supply hose, internal drain hose, and external drain hose should already be connected as described earlier in this Work Package. Fill the water system as follows:

CAUTION

The switches for the water pump and water heater (located on the appliance control box) must be left OFF until the water system and water heater are filled. Energizing these items without water in them will result in equipment damage.

In freezing weather, the water tank trailer should be located as close to the fabric penetration as possible. Additional procedures to prevent freezing are described in WP 0007 00.

1. Ensure that both drain valves in the sink assembly are fully closed. The valves are located at the back of the assembly under the water heater – one for the heater and one for the cold water line. If necessary, unlock the sink assembly casters and temporarily move the sink assembly to check the valves.

**CONTAINERIZED KITCHEN (WITH TRAILER)
OPERATION UNDER USUAL CONDITIONS**

2. Open the hot and cold water handles to eliminate back pressure on the pump.

CAUTION

Do not run the water pump for more that approximately one minute without water. If water is not running from the faucet after this time, shut off the pump at the appliance control box and check for kinks or leaks in the supply hose. The water heater must be left OFF until it has been filled.

3. Position the WATER PUMP switch on the appliance control box to ON.
4. Turn off the cold water when a steady stream of water runs from the faucet. After a short time for the water heater to fill, turn off the hot water when a steady stream runs from the faucet. After the water is turned off, the pump will automatically stop after a few seconds.
5. Position the WATER HEATER switch on the appliance control box to ON.
6. To fill the tray pack heater or steam table, retrieve the short water supply hose from the base of the sink assembly, connect the female end to the faucet, and fill these items as desired. When no longer needed, drain the hose, coil it, connect its ends together to minimize the possibility of contamination, and restow it in the sink assembly base.

**CONTAINERIZED KITCHEN (WITH TRAILER)
OPERATION UNDER USUAL CONDITIONS**

KITCHEN OPERATION**Generator**

A detailed description of generator operation is provided in TM 9-6115-642-10.

Modern Burner Units

A detailed description of MBU operation is provided in TM 10-7310-281-13&P. Check that the MBU POWER switch is ON before attempting to start the MBUs. To ensure sufficient air flow for MBU ignition, the cook center ventilation fans should be running before lighting any MBUs in the cook center. Also, when lighting the two MBUs in either section of the cook center, the right-hand MBU in the section should be lit first.

WARNING

Gasoline must NOT be used in the MBUs under any circumstances. Only JP-8 or an approved alternate diesel fuel may be used. Using gasoline in the MBU will create a fire danger and potential for explosion.

Environmental Control Unit

Operation of the Environmental Control Unit is fully automatic once the desired mode is selected with the ECU control switch. The available modes are off, low cooling, high cooling, and heat. The system operates until it is turned off; there is no temperature setpoint adjustment.

NOTE

The Environmental Control Unit has time delay features that cause several minutes delay before the system starts, and each time the control switch position is changed. If the system does not start after approximately five minutes, reset the control circuit by cycling the controller's circuit breaker (#18 on the Power Distribution Panel) OFF and back ON.

Exhaust Hood Ventilation

Exhaust hood ventilation is controlled by the fan speed control located to the right of the spice rack. Rotate the knob clockwise to increase fan speed and counter-clockwise to reduce it. Turning the knob fully counter-clockwise shuts off the fans. The exhaust system should not normally be operated above about 75% fan speed (control knob turned clockwise approximately $\frac{3}{4}$ of its travel) as this is enough to exhaust smoke and steam generated at the cook center under normal cooking conditions. The remaining capacity is available if needed to exhaust unusually large amounts of smoke or steam; however, operating the fans at higher speed increases the noise level in the kitchen and is not recommended unless necessary.

**CONTAINERIZED KITCHEN (WITH TRAILER)
OPERATION UNDER USUAL CONDITIONS**

KITCHEN PACKOUT AND PREPARATION FOR TRANSPORT

Introduction

The ISO expandable shelter serves as the primary container for the CK. Upon completion of an operational deployment, the CK is packed for transport within the shelter. All components must be packed in the order and locations specified in the following paragraphs to ensure that everything will fit and to prevent damage during transport.

The packout procedures which follow assume that all foodstuffs and other items not part of the CK's inventory are removed before initiating packout. In specific tactical situations, however, the Unit Commander or Unit Standard Operating Procedures may direct that the CK be packed out and moved with food or other items on board. In such cases, the packout procedures may be locally modified as required.

With one exception that will be explained later in this Work Package, when a ratchet strap is called for, place the long strap section toward the mechanical room and the short ratchet section toward the personnel door. Ensure that the straps are straight. Tighten the straps slightly, move the piece of equipment slightly to ensure that the straps are secure, then completely tighten the straps.

Figure 15 illustrates the packout locations of the appliances and other major components. Table 2 provides a checklist of the loose items and gives the recommended packout location of each item. Further information and instructions for packout are provided in the following paragraphs.

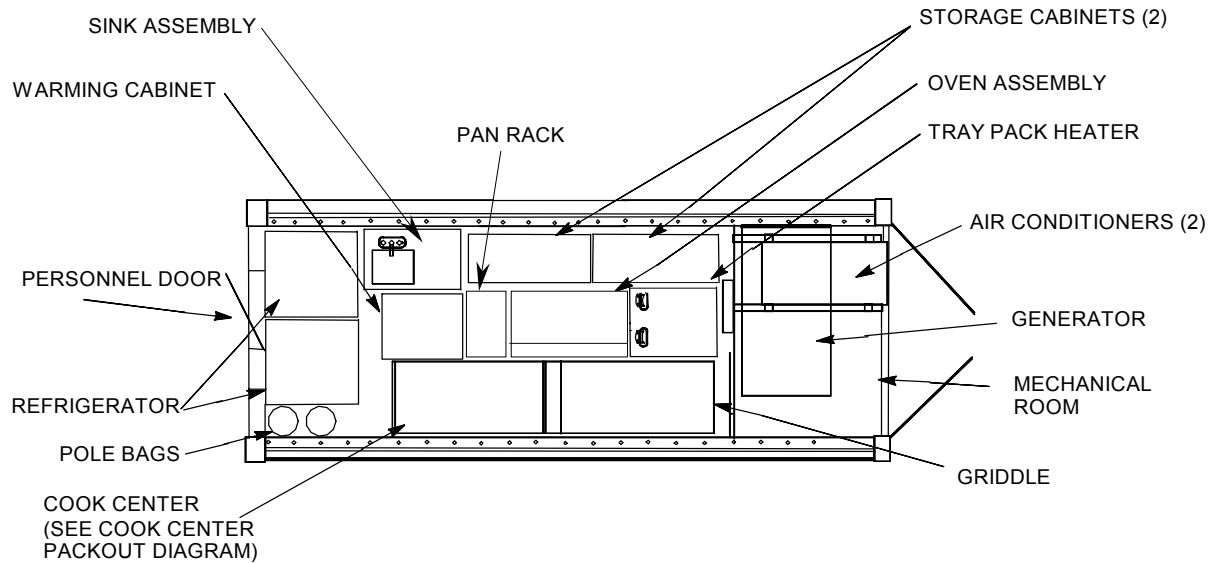

Figure 15. Major Component Packout Locations.

Preparation for Packout

Before beginning packout, prepare the CK as follows. Except as noted, these steps may be performed simultaneously or in any convenient order.

**CONTAINERIZED KITCHEN (WITH TRAILER)
OPERATION UNDER USUAL CONDITIONS**

WARNING

Ensure that all CK components have completely cooled before initiating packout, or personal injury may result.

1. Turn off all MBUs and the water heater and allow the equipment to cool. If they were recently used, the steam table, tray pack heater and water heater will contain hot water that may take an hour or more to cool.
2. Remove all food and trash from the kitchen and clean the utensils, pots, pans, griddle, grease filters, grease cup, grease trap, table tops, etc. as necessary. Place the clean utensils in the baking/roasting pans.
3. Turn off the refrigerators and mobile warming cabinet and clean them.
4. Turn off the cook center ventilation. The generator, lights and ECU may be left on if desired.
5. Disconnect both ends of the water supply hose and internal drain hose. Drain the supply hose, coil it tightly, and connect its two ends together to minimize the possibility of contamination. Pack the supply hose on the lower shelf of the sink assembly. If it is not needed to drain the steam table, coil the internal drain hose and pack it in the back of the sink assembly.
6. If necessary, drain the steam table after it has cooled. Connect the internal drain hose to the steam table drain connection and the floor drain connection. Remove the stopper and allow the table to drain. Replace the stopper when draining is complete. Disconnect the drain hose, coil it, and pack it in the back of the sink assembly. If necessary, remove the floor drain cover and clean the drain.
7. After it has cooled, drain the water heater. Open both faucet valves, both drain valves (located under the water heater) and collect the water in a suitable container. Close all of the valves when draining is complete. The collected water can be poured into the floor drain.
8. If the tray pack heater must be drained, leave the external drain hose in place – it will be removed later. If not, disconnect the hose and drain it. Coil it tightly, and pack it on the lower shelf of the sink assembly. Install the cap on the external drain connection.

**CONTAINERIZED KITCHEN (WITH TRAILER)
OPERATION UNDER USUAL CONDITIONS**
Table 2. Loose Item Packout List.

ITEM	QTY	PACKOUT LOCATION
Fire extinguisher	4	Wall brackets
Ground rod assembly	1	Brackets inside the left door of the mechanical room
Ground rod slide hammer	1	Mechanical room, on top of stair/ladders
Wing jack	8	On top of stair/ladders in the mechanical room
Screw jack	2	Brackets on the left door of the mechanical room
Screw jack extension/base plate	2	Brackets on the floor of the mechanical room
Corner jack	2	Brackets on the left door of the mechanical room
Corner jack extension/base plate	2	Brackets on the left door of the mechanical room
Jack/winch handle	2	Straps on the side of the rifle rack
Tech manuals (CK, MBU)	2	In manual holder
Work table drawer	2	Inside the oven
Oven exhaust pipe	1	In work table drawer
Cook pot cradle adapter	4	Top of the griddle, wrapped in the packing blanket
Modern Burner Unit (MBU)	6	In place
Cook pot cradle	2	Under the cook center
Cook pot cradle burner rack	1	Top of the tray pack heater
Cook pot cradle base rack	1	Top of the tray pack heater
Griddle top	1	On the left half of the cook center
Steam table body	1	On the right half of the cook center
Steam table adapter top	1	On top of the steam table body
Beverage dispenser	8	Top shelves of the mobile storage cabinets
Board, food slicing and chopping	2	In baking/roasting pan
Can, water, plastic, 5-gallon	6	Inside the mechanical room
Can opener, hand	2	In baking/roasting pan
Colander, SS, 16-quart	1	In baking/roasting pan
Dipper, 32-ounce	4	In baking/roasting pan
Egg whip	2	In baking/roasting pan
Fork, 15-inch	4	In baking/roasting pan
Fork, 21-inch	4	In baking/roasting pan
Ice cream scoop, size 6	4	In baking/roasting pan
Knife, boning, 6-inch	3	In baking/roasting pan or knife rack
Knife, cook's, 10-inch	3	In baking/roasting pan or knife rack
Knife, paring, 3.25-inch	4	In baking/roasting pan or knife rack
Knife, steak, scimitar	3	In baking/roasting pan or knife rack

**CONTAINERIZED KITCHEN (WITH TRAILER)
OPERATION UNDER USUAL CONDITIONS**

Table 2. Loose Item Packout List – Continued.

ITEM	QTY	PACKOUT LOCATION
Ladle, 8-ounce, 12-inch handle	4	In baking/roasting pan
Measuring cup, 4-quart	2	In baking/roasting pan
Measuring set, spoons	2	In baking/roasting pan
Pan, baking/roasting, w/cover	4	Under the cook center, left side
Pans, baking, full size	10	Inside the mobile warming cabinet
Peeler, potato, hand	3	In baking/roasting pan
Pot, cooking, 10-gal, w/cover	3	Nested inside each other, on the lower shelves of the mobile storage cabinets
Pot, cooking, 15-gal, w/cover	3	Lower shelves of the mobile storage cabinets
Skimmer, kitchen	2	In baking/roasting pan
Spoon, food service, 15-inch	4	In baking/roasting pan
Spoon, food service, 21-inch	4	In baking/roasting pan
Spoon, serving, slotted, 15-inch	4	In baking/roasting pan
Steam table pan, full size	8	Nested on the floor inside the pan rack
Steam table pan, half size	4	Nested on the floor inside the pan rack
Tongs, food service, 12-inch	4	In baking/roasting pan
Food turner (spatula), 20-inch	4	In baking/roasting pan

Equipment Packout

WARNING

Ensure that all components have completely cooled before initiating packout.

Cook Center

Figure 16 illustrates the locations of the items packed on or within the cook center.

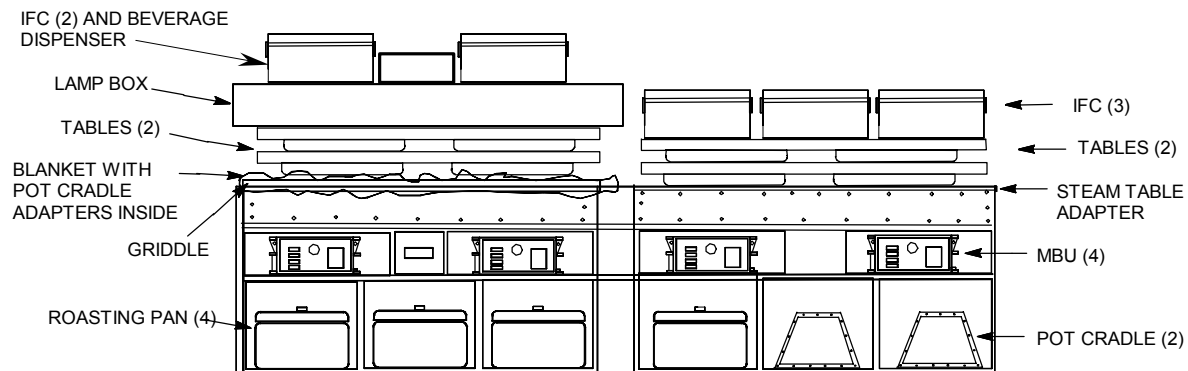

Figure 16. Cook Center Packout.

Referring to Figure 16, pack out the cook center as follows:

1. Pack the MBUs, griddle and grease pan in place. If installed, remove the splash guards.
2. Place the packing blanket over the griddle. Place the four cook pot cradle adapters on the blanket and fold the blanket over them.

**CONTAINERIZED KITCHEN (WITH TRAILER)
OPERATION UNDER USUAL CONDITIONS**

3. Place the two cutting boards in one of the empty baking/roasting pans. Remove any utensils remaining in the table drawers and pack them on top of the cutting boards. Remove the drawer assemblies from the tables and stow them in the oven. Strap them down using two long rubber straps from back to front.
4. Place two tables, with the legs folded, on the griddle. Ensure the legs are correctly folded so the tables lie flat. Stack the tables with their legs down.
5. Retrieve the light storage box and remove any items stored inside. Unplug and take down the removable light fixtures and place them in the box. Place the griddle splash guards on top of the fixtures. Be sure that the corner clips on the side splash guards are facing down.

WARNING

The packed light storage box weighs approximately 100 lbs (45.4 kg). Three persons must carry the box, lifting with legs not back, to prevent injury.

6. Place the light storage box on top of the tables. Center the box on the tables.
7. Place two insulated food containers on the light storage box, with one beverage dispenser on its side between them. Center the containers on the box.
8. Place one ratchet tie-down strap over all of the above items. Attach the strap end to the tie-down provision at the mechanical room end of the cook center, and the ratchet end to the tie-down provision at the center of the cook center. Tighten the strap securely.
9. Pack the steam table and adapter top in place. Place four full-size steam table pans in the adapter top.
10. Place two tables, with the drawers removed and the legs folded, on the steam table and adapter top. Ensure the table legs are correctly folded so the tables lie flat. Stack the tables with their legs down.
11. Place three insulated food containers on the tables. Center the containers on the tables.
12. Place one ratchet tie-down strap over all of the above items. Attach the strap end to the tie-down provision at the center of the cook center, and the ratchet end to the tie-down provision at the right end of the cook center. Tighten the strap securely.
13. Place the lids on each of the four roasting pans. Place one pan in each of the four leftmost compartments in the base assembly.
14. Place one pot cradle in each of the two rightmost compartments.

Tray Pack Heater

1. Pack the MBU in place. Disconnect the fuel and power lines, coil them, and pack them in the bottom of the oven assembly. Ensure the fuel line dust plug is in place.
2. Unplug the heater fan power cable from the appliance control box and remove the heater fan assembly from the back of the tray pack heater. If the tray pack heater must be drained, temporarily set the fan assembly aside in a convenient location. Otherwise, pack the assembly inside the tray pack heater.

**CONTAINERIZED KITCHEN (WITH TRAILER)
OPERATION UNDER USUAL CONDITIONS**

WARNING

Do NOT use one of the water supply hoses to drain the tray pack heater. They are for potable water use and could become contaminated.

3. If the tray pack heater must be drained, roll it to the area of the personnel access door, open its drain valve, and drain the water into the floor drain. Close the valve when draining is complete. Pack the heater fan assembly inside the tray pack heater.
4. If necessary, disconnect the external drain hose and drain it. Tightly coil the hose and pack it on the lower shelf of the sink assembly.
5. Position the tray pack heater as shown earlier in Figure 15, with its back to the mechanical room wall. Place the base rack inside the burner rack and set both on top of the heater.
6. Place two ratchet straps over these items, running from the loops on the mechanical room wall down to the tie-down provisions in the floor. Tighten the straps securely.

Oven Assembly

1. Pack the MBU in place with its fuel and power lines connected.
2. Unplug the oven's 24 VDC and 120 VAC power cables from the ceiling raceway. Coil the 120 VAC cable and lay it on top of the oven. Coil the 24 VDC cable, along with the fuel line and power cable to the tray pack heater, and pack them between the MBU and the left side of the oven base.
3. Move the pan rack out of the way and disconnect the fuel line from its outlet at the mechanical room wall. Install the dust plugs. Coil the hose and pack it between the MBU and the right side of the oven base.
4. Pull the oven assembly away from the fabric wall far enough to remove the chimney pipe. Remove the pipe and stow it in one of work table drawers inside the oven.
5. Hook the long section of two ratchet straps to the same floor tie-down provisions used for the tray pack heater, and temporarily drape the straps over the heater.
6. Position the oven assembly as shown earlier in Figure 15, with its back toward the cook center, and strap it down with the two ratchet straps run from side to side. Run the straps under the oven fan assembly, not over the top of it.

**CONTAINERIZED KITCHEN (WITH TRAILER)
OPERATION UNDER USUAL CONDITIONS**

Refrigerators

1. Place four insulated food transporters in each refrigerator, one on each shelf.
2. Strap the containers to the shelves using one short rubber strap over each container, placed from back to front.

CAUTION

When moving a refrigerator, use the metal bracket on the back for a handhold. Do not grasp the plastic tube running down the back of the unit or it may be damaged.

3. Unplug the refrigerators and temporarily move them to the serving wing while completing packout and closure of the food preparation wing.

Pan Rack

1. Position the pan rack to the right of the oven assembly, with its back to the cook center. Nest the large and small steam table pans and set them on the floor inside the pan rack. Strap down the rack and pans from side to side using two long rubber straps run through the rails of the rack and cross them above the pans.

Mobile Warming Cabinet

1. Unplug the power cord, coil it, and hang it from the holder on the back of the unit.
2. Stack all the baking pans on the bottom slides.
3. Stack three insulated food containers on top of the pans.
4. Place all remaining loose slides on top of the top insulated food container.
5. Place two short rubber straps crossed over the top of the loose slides and containers. Hook the straps to the front rack hangers. Stretch the straps across and up and hook them to the rear rack hangers, ensuring that the strap hooks are completely hooked into holes in the rack hangers.
6. Close and latch the warming cabinet doors.
7. Position the warming cabinet as shown earlier in Figure 15, with its back to the side of the pan rack, and strap it down with two ratchet straps run from back to front.

Mobile Storage Cabinets

1. Place four beverage dispensers on the top shelf of one of the storage cabinets and strap them in place with one short rubber strap across the front of the shelf. Place three beverage dispensers on the top shelf of the other cabinet; do not strap these in place.
2. Nest the 10-gallon pots inside each other. Place them and the 15-gallon pots on the bottom shelves of the storage cabinets. Place the pot lids on top of the pots. Strap them in place with one short rubber strap placed across the front of the pots.
3. Place the storage cabinet containing three beverage dispensers next to the tray pack heater as shown earlier in Figure 15, with its front facing the cook center. Position the beverage dispensers so the oven door handle fits into the empty space. Strap the cabinet down with one ratchet strap run from side to side, oriented so the ratchet section is toward the mechanical room (note that this is the reverse of how all other ratchet straps are oriented, and prevents the

**CONTAINERIZED KITCHEN (WITH TRAILER)
OPERATION UNDER USUAL CONDITIONS**

ratchet from being trapped between the two cabinets and damaging them during transit). Tighten the strap securely.

4. Place the second storage cabinet next to the first, with its front facing the cook center. Strap it down with one ratchet strap run from side to side. Tighten the strap securely.

Hand Sink Assembly

1. Tightly coil the internal drain hose and pack it in the back of the sink assembly.
2. Tightly coil the water supply hose and connect its ends together to prevent contamination. Tightly coil the external drain hose. Pack both hoses on the lower shelf of the sink assembly.
3. Unplug the water heater and water pump power cables from the appliance control box, coil them, and stow them in the back of the sink base. Unplug the appliance control box, coil its cord, and stow it in the sink base assembly.
4. Locate the sink assembly as shown earlier in Figure 15, with its front to the side of the mobile warming cabinet, and strap it down with one ratchet strap run from side to side. Tighten the strap securely.

Food Preparation Wing Closure

1. Close and secure the windows in the food preparation wing.
2. Retrieve any ratchet straps and rubber straps still hanging in the food preparation wing and place them in a convenient location in the serving wing.
3. Retrieve the empty arch component storage bags.

WARNING

A storage bag filled with shelter arch components weighs approximately 130 lbs (59 kg). Three persons must carry the bag, lifting with legs, not back, to prevent injury.

4. Remove the adjustable spacer. Starting in the middle of the wing, remove the arch spacers and arch frame assemblies (it may be necessary for personnel to push up on the fabric while removing the assemblies). Disassemble the components and place them in one of the storage bags. Temporarily move the bag to the serving wing so it is out of the way.
5. If still running, turn off the ECU and then shut down the generator from the generator control panel.
6. Remove the locking pins attaching the three wing jacks to the wing, and remove the jacks. It may be necessary to retrieve a winch handle and crank the wing up slightly to take the weight off the pins before they can be removed.
7. If installed, remove the platform rail, platform, and stair/ladder at the personnel door and temporarily set them out of the way (the platform will interfere with the winch handle).

WARNING

When raising or lowering the wings, one member of the crew must act as a spotter to ensure that all personnel stay clear.

8. If not already done, retrieve a jack/winch handle from its storage location on the side of the rifle rack.

**CONTAINERIZED KITCHEN (WITH TRAILER)
OPERATION UNDER USUAL CONDITIONS**

9. Winch up the wing using the left winch. When the wing is approximately halfway up, stop winching. Push in on the fabric at each end of the wing so it will properly fold up as the wing is closed.
10. Continue winching up the wing. When it is nearly closed, climb onto the container and attach the orange safety strap. After the strap is attached, unlock and rotate the four cam-locks on the side of the wing 90° so their handles are pointing straight outward.
11. Continue winching up the wing until it is almost closed and the winch becomes hard to turn. The spotter can advise the person operating the winch when the wing is almost closed.
12. Partially close the four cam-locks by rotating their handles approximately 45° toward their locked position. Crank the wing closed a few more turns, then completely engage and lock the cam-locks.

Refrigerator Tie-Down

1. Place the long ends of three ratchet straps in the tie-down provisions for the first refrigerator.
2. Referring to Figure 15, position the right-hand hinged refrigerator with its front facing outboard toward the closed food preparation wing. Place the three straps over the top of the refrigerator, two from side to side and one from front to back. Move the refrigerator into its final position. Attach the ratchet end of each strap to the appropriate tie-down provision in the floor and tighten the straps securely.
3. Place the long ends of three ratchet straps in the tie-down provisions for the second refrigerator.
4. Position the second refrigerator with its back facing the back of the first refrigerator. Place the three straps over the top of the refrigerator, two from side to side and one from front to back. Move the refrigerator into its final position. Attach the ratchet end of each strap to the appropriate tie-down provision in the floor and tighten the straps securely.

Serving Wing Closure**WARNING**

A storage bag filled with shelter arch components weighs approximately 130 lbs (59 kg). Three persons must carry the bag, lifting with legs, not back, to prevent injury.

1. Place the bag of shelter arch components from the food preparation wing against the refrigerator, angling the bag so one end is against the ceiling and the other against the side of the cook center.
2. Close and secure all doors and windows in the wing except the door nearest the personnel access door. Fold the bottom of the door inward and push it under the door so it will not be caught when the wing is closed.
3. Retrieve the remaining arch component storage bag.
4. Remove the curved spacers and place them in the storage bag. Starting in the middle of the wing, remove the arch spacers and arch frame assemblies. Disassemble the frame assemblies and place the components in the storage bag. Close the bag and place it beside the other one, against the refrigerator.
5. If installed, remove the stair/ladders.

**CONTAINERIZED KITCHEN (WITH TRAILER)
OPERATION UNDER USUAL CONDITIONS**

6. Secure the remaining serving door. Fold the bottom of the door inward and push it under the door so it will not be caught when the wing is closed.
7. Remove the locking pins attaching the three wing jacks to the wing, and remove the jacks. It may be necessary to crank the wing up slightly to take the weight off the pins before they can be removed.

WARNING

When raising or lowering the wings, one member of the crew must act as a spotter to ensure that all personnel stay clear.

8. Winch up the wing using the right winch. When the wing is approximately halfway up, stop winching. Push in on the fabric at each end of the wing so it will properly fold up as the wing is closed.
9. Continue winching up the wing. When it is nearly closed, climb onto the container and attach the orange safety strap. After the strap is attached, unlock and rotate the four cam-locks on the side of the wing 90° so their handles are pointing straight outward.
10. Continue winching up the wing until it is almost closed and the winch becomes hard to turn. The spotter can advise the person operating the winch when the wing is almost closed.
11. Partially engage the four cam-locks by rotating their handles approximately 45° toward their locked position. Crank the wing closed a few more turns, then completely engage and lock the cam-locks.
12. Return the jack/winch handle to its storage location on the side of the rifle rack. Strap it in place with its handle end up.
13. Pack the three pairs of stair railings upside down just inside the personnel door. Strap the railings in place on both sides of the door using two short rubber straps.
14. On the Main Control Panel, turn the INTERIOR LIGHTING and EMERGENCY LIGHT switches OFF.
15. Close and latch the personnel door.

Jack Removal

If they were used, remove the corner jacks and screw jacks as follows.

1. Lower the corner jacks until the end of the container is resting on the ground. Remove the jacks.
2. Install the corner jacks at the opposite end of the container. Raise the end of the container just until the weight is off of the screw jacks. Remove the screw jacks.
3. Lower the corner jacks until the end of the container is resting on the ground. Remove the jacks.

**CONTAINERIZED KITCHEN (WITH TRAILER)
OPERATION UNDER USUAL CONDITIONS**

Mechanical Room Packout**WARNING**

To prevent personal injury, notify personnel inside the CK before removing the platform from in front of the personnel door.

1. If the CK is mounted on a trailer, install the platform at the mechanical room doors. Hook the platform into the bracket on the container and support the other side using two wing jacks.
2. Unbuckle the awning from both doors and lay it up out of the way.
3. Remove the awning support bar from the brackets on the doors. Slip the straps from the generator, air conditioner, and exhaust fan ducts from the awning rod. Leave the loops in the straps, and the ducts attached to the units.
4. Store the awning support bar on the floor just inside the mechanical room.
5. Stuff the generator and air conditioner ducts into the openings of the units so that they are not in the way. Drape the hood exhaust duct behind the generator discharge hood.
6. Remove the two door braces and store them on the floor underneath the air conditioners.

WARNING

Ensure that the generator exhaust pipe has completely cooled before attempting to disassemble the elbow pipe.

7. Remove the generator exhaust elbow pipe by loosening the clamp and slipping the elbow through the awning from above. Store it at the right end of the generator. Leave the clamp attached to the exhaust pipe end at the ceiling of the mechanical room.
8. Unscrew the awning from the door frame. Fold it and pack it on top of the generator.
9. Retrieve the ground rod assembly, clean it, and store it in its brackets next to the Power Entrance Panel.
10. If they were used, place the screw jack extension/base plates at the left end of the generator. Strap them down with two short rubber straps.
11. Disconnect the MBU fuel line at the connection below the Power Entrance Panel. Remove the fuel can adapter from the can, place it in its storage bag, and pack it on the floor to the left of the generator. Put the cap on the fuel can and remove the can from the mechanical room. Stow the strap in any convenient place in the mechanical room.
12. Disconnect the generator's auxiliary fuel line at the other fuel can. Remove the fuel can adapter from the can, place it in its storage bag, and pack it on the floor to the left of the generator. Put the cap on the fuel can.
13. Coil the generator's auxiliary fuel line and stow it on the floor to the left of the generator.
14. Disconnect the wing jacks from the platform. Remove the platform and slide it, with the edge containing the jack brackets up, between the screw jack extension/base plates and the front of the generator. Pack the platform railing next to the platform.
15. Place the long portions of two ratchet straps into the two loops located at the base of the generator. Temporarily place the loose ends of the straps on top of the generator.

**CONTAINERIZED KITCHEN (WITH TRAILER)
OPERATION UNDER USUAL CONDITIONS**

16. Place the three stair/ladders on their sides with their tops to the left.
17. Place the 6 water cans, on their sides, between the stair/ladder treads.
18. Place the ground rod slide hammer on top of the stair/ladders.
19. Strap the stair/ladders and slide hammer in place by bringing the two ratchet straps over them and securing them to the rings on the floor. Tighten the straps securely.
20. Place the wing jacks, with their base plates to the left, on top of the stair/ladders. Slide the tops of the jacks under the air conditioner and secure the jacks to the stair/ladders using two short rubber straps.
21. If the corner jacks and screw jacks were used, separate the jack bodies from the extension/base plates. Store the corner jacks bodies, their extension/base plates, and the screw jack bodies in their storage brackets on the left door. Ensure that the jacks and base plates are properly secured to the brackets.
22. Stow the screw jack extension/base plates on the floor to the left of the generator and strap them down with a short rubber strap.
23. Ensure that the ends of the two air conditioner condensation drain lines are stowed inside the mechanical room so they will not be damaged when the doors are closed.
24. Closing the left door first, close and latch the mechanical room doors.
25. Place all three fuel cans in a Food Service Section vehicle.

END OF WORK PACKAGE

**CONTAINERIZED KITCHEN (WITH TRAILER)
OPERATION UNDER UNUSUAL CONDITIONS**

INITIAL SETUP:

Kitchen set up and operating

Maintenance Level

Operator/Crew

Personnel Required

Four (plus one supervisor)

GENERAL

This work package provides instructions for operating the CK under unusual conditions. These include adverse weather; nuclear, biological, and chemical attack; and emergency blackout conditions.

ADVERSE WEATHER CONDITIONS**Operation in Rain and/or Mud**

1. Provide an adequate drainage ditch to prevent standing water around the CK.
2. Frequently check the jacks for sinking. Level the container as required by adjusting the corner jacks, screw jacks, or trailer jacks, as applicable. It may also be necessary to adjust the wing jacks to maintain level floors.
3. Close and secure all shelter doors except the mechanical room doors. These cannot be shut when the CK is set up for operation.
4. Check door seals for proper placement and compression.
5. From the inside, inspect the CK for leaks.

Operation in Hot Weather**WARNING**

High heat generated during CK operation may be a health hazard. The section supervisor must constantly monitor personnel and follow local Standard Operating Procedures.

1. Operate the MBUs at the lowest setting that will ensure proper cooking.
2. Minimize the use of electrical appliances. This makes more power available for the air conditioners.
3. For better ventilation, open the windows and doors. The windows can be rolled up and secured with the straps provided. The serving wing doors can be rolled up from inside the kitchen and wedged between the shelter roof and the arched spacer above each doorway.
4. The ECU is designed to provide some degree of comfort to cooks in the food preparation area. It is not designed to cool the entire CK.

**CONTAINERIZED KITCHEN (WITH TRAILER)
OPERATION UNDER UNUSUAL CONDITIONS**

Operation in Snow, Ice, or Extreme Cold**WARNING**

In extreme cold, do not touch metal parts with bare hands. Severe skin damage may result.

NOTE

Fluorescent lights may be slow to light at very low temperatures.

1. If freezing conditions exist or are possible while the CK is set up and operating, the external water supply and drain should not be used.

CAUTION

At temperatures below freezing, the water supply and drain hoses will be stiff. Do not attempt to straighten or coil a frozen hose or equipment damage may result. Place the hoses inside the heated shelter until they have warmed enough to be coiled.

2. If connected, disconnect and drain the water supply hose and the external drain hose. Coil each hose and store them in the hand sink assembly.
3. To use the hand sink, connect one of the 25-ft water supply hoses to the supply connection on the back of the sink assembly. Position a filled 5-gallon potable water can beside the sink assembly and insert the other end of the hose into the can.

NOTE

The water heater holds about 6 gallons. If it is not already full from prior use of the sink, at least two filled water cans will be needed to start.

4. Collect drainage from the hand sink in a suitable container placed underneath the external drain hose connection.
5. Keep all doors and windows closed.
6. Lubricate door weather seals with silicone spray (WP 0051 00, Table 1, Item 4) to prevent sticking.
7. Adjust the air curtain dampers along the front edge of the cook center hood if the air is uncomfortably cold.
8. Run the cook center fans at the lowest practical level to avoid removing warm inside air.
9. Do not allow ice and snow to build up on the wing roofs. As necessary, remove any accumulation with a soft bristle brush, broom, or equivalent.
10. Remove ice and snow from the wing roofs before folding them.

**CONTAINERIZED KITCHEN (WITH TRAILER)
OPERATION UNDER UNUSUAL CONDITIONS**

Draining the Water System

If freezing conditions are possible while the CK is packed for transport, or the kitchen is to be left set up but unheated during possible freezing conditions, drain the water system to prevent damage.

1. Turn off the water pump and water heater at the appliance control box.
2. Disconnect and drain the water supply hose. If packing the kitchen for transport, coil the hose, connect its two ends together, and store it on the lower shelf in the front of the sink assembly.
3. Open the hot and cold water faucets to release the pressure in the system. Leave the faucets open.
4. Drain the cold water line into a pan, bucket, or other container by opening the drain valve at the back of the sink assembly.
5. Drain the water heater into a suitable container by opening the water heater drain valve.
6. With both drain valves open, turn on the water pump for several seconds to purge the pump of water. Turn off the pump when there is no sign of water coming from the drains.
7. If necessary, slightly tilt the sink assembly to drain any water remaining in the sink bowl and drain pipe.
8. Disconnect the interior drain hose from the sink assembly and drain it into the floor drain. If packing the kitchen for transport, disconnect the hose from the fitting on the floor drain, coil it, and store it on the shelf in the back of the sink assembly.
9. Disconnect and drain the external drain hose. If packing the kitchen for transport, coil the hose tightly and store it in the lower shelf in the front of the sink assembly.
10. Ensure that the hot and cold water lines and the water heater are completely drained, then close the drains and faucets.

FORDING AND SWIMMING

In the packed-out configuration, the CK is not watertight. It should never be submerged in any depth of water or equipment damage may result. When mounted on a trailer, hard-bottom water crossings no deeper than approximately 2 feet can be forded. When in doubt, refer to Unit Standard Operating Procedures.

INTERIM NUCLEAR, BIOLOGICAL, AND CHEMICAL (NBC) DECONTAMINATION PROCEDURES

When an NBC attack is expected, and time allows, the kitchen should be packed for transport per WP 0006 00 until the threat of attack is over. If an NBC attack occurs, the unit must be decontaminated before use in accordance with FM 3-5.

JAMMING AND ELECTRONIC COUNTERMEASURES

The CK is not affected by jamming or electronic countermeasures.

**CONTAINERIZED KITCHEN (WITH TRAILER)
OPERATION UNDER UNUSUAL CONDITIONS**

EMERGENCY PROCEDURES**Operation During Blackout Conditions**

Meal preparation and serving can be conducted during blackout conditions. Kitchen doors should be opened only as necessary, and should be closed as soon as possible.

1. Ensure that all door and window flaps are closed and sealed.
2. With the LIGHTING MODE switch on the Main Control Panel in NORMAL, turn on the interior lights and check the perimeter of the kitchen from at least 25 feet away to ensure no light is visible.
3. Place the LIGHTING MODE switch in the BLACKOUT position.

END OF WORK PACKAGE

**CHAPTER 3
TROUBLESHOOTING PROCEDURES
FOR
CONTAINERIZED KITCHEN (WITH TRAILER) [CK]**



CONTAINERIZED KITCHEN (WITH TRAILER)
INTRODUCTION

MALFUNCTION/SYMPTOM INDEX

The malfunction/symptom index (WP 0009 00) is a quick reference for finding troubleshooting procedures. Associated with each symptom name is a work package sequence number representing the starting point in a troubleshooting sequence. As the troubleshooting activity progresses through to the conclusion of a sequence, a reference is made to the next logical troubleshooting sequence by work package sequence number or by referring to the malfunction/symptom index to locate the next failure symptom work package. This type of activity continues until successful fault isolation is achieved.

TROUBLESHOOTING PROCEDURES

The troubleshooting work packages contain tables listing the malfunctions, checks or inspections, and corrective actions required to return the equipment to normal operation. Perform the steps in the order they appear in the tables.

Each work package is headed by an initial setup. This setup outlines what is needed as well as the conditions that must be met before starting the task. **DO NOT START A TASK UNTIL:**

You understand the task.

You understand what you are to do.

You understand what is needed to do the work.

You have the things you need.

This manual cannot list all malfunctions that may occur, or all tests, inspections and corrective actions. If a malfunction is not listed or is not corrected by listed corrective actions, notify unit maintenance.

GENERAL INFORMATION

When troubleshooting the electrical system with power connected, place all switches and circuit breakers in the OFF position.

If any circuit breaker trips after it has been reset, notify unit maintenance.

**CONTAINERIZED KITCHEN (WITH TRAILER)
MALFUNCTION/SYMPTOM INDEX**

MALFUNCTION/SYMPTOM

TROUBLESHOOTING PROCEDURE

Electrical System

No power to kitchen – external source WP 0010 00
 No power to kitchen – generator source..... WP 0010 00
 Generator will not crank WP 0010 00
 Generator cranks but does not start..... WP 0010 00
 Interior lights do not work WP 0010 00
 No power at one or more receptacles WP 0010 00

Modern Burner Unit (MBU)

MBU does not power up..... WP 0011 00
 MBU powers on but does not start WP 0011 00
 MBU shuts down during operation WP 0011 00
 MBU fails to fuel..... WP 0011 00

Environmental Control Unit

Air conditioners running but are not cooling WP 0012 00
 Heater does not start..... WP 0012 00

Hand Sink Assembly

No hot or cold water WP 0013 00
 Low water pressure..... WP 0013 00
 No hot water WP 0013 00
 Water is still cold after 30 minutes..... WP 0013 00
 Water is too hot..... WP 0013 00
 Sink drains slowly or does not drain..... WP 0013 00
 No soap from dispenser WP 0013 00

Kitchen Appliances

Refrigerator does not operate WP 0014 00
 Refrigerator operates but does not cool WP 0014 00
 Mobile warming cabinet does not heat WP 0014 00
 Tray pack heater fan does not work WP 0014 00
 Oven fans do not work WP 0014 00

CONTAINERIZED KITCHEN (WITH TRAILER) TROUBLESHOOTING PROCEDURES (ELECTRICAL SYSTEM)

THIS WORK PACKAGE COVERS:

Electrical System

INITIAL SETUP:

Kitchen set up

Maintenance Level

Operator/Crew

ELECTRICAL SYSTEM MALFUNCTIONS

Table 1. Troubleshooting Procedures (Electrical System)

Malfunction	Test or Inspection	Corrective Action
No power to kitchen – external source	EXTERNAL POWER AVAILABLE indicator (Main Control Panel) is not lit	Ensure that the external power cable is properly connected (Power Entrance Panel) Ensure that the power cable is connected to the source and the source is energized Ensure that the external power control circuit breaker (Power Entrance Panel) is closed (pushed in) Notify unit maintenance
	EXTERNAL POWER AVAILABLE indicator is lit, EXTERNAL POWER indicator is not lit	Press the EXTERNAL POWER pushbutton (Main Control Panel) Notify unit maintenance
	EXTERNAL POWER AVAILABLE indicator is lit and EXTERNAL POWER indicator is lit	Check/reset the input power circuit breaker (#1 on Power Distribution Panel) Notify unit maintenance
No power to kitchen – generator source	Generator is running, GENERATOR POWER AVAILABLE indicator is not lit	Check/close the AC CIRCUIT INTERRUPTER switch (generator control panel)

**CONTAINERIZED KITCHEN (WITH TRAILER)
TROUBLESHOOTING PROCEDURES (ELECTRICAL SYSTEM)**

Table 1. Troubleshooting Procedures (Electrical System) – Continued

Malfunction	Test or Inspection	Corrective Action
Generator will not crank	GENERATOR POWER AVAILABLE indicator is lit, GENERATOR POWER indicator is not lit.	Ensure that the generator power control circuit breaker (Power Entrance Panel) is shut (pushed in) Notify unit maintenance Press the GENERATOR POWER pushbutton (Main Control Panel)
	GENERATOR POWER AVAILABLE indicator is lit, GENERATOR POWER indicator is lit	Notify unit maintenance Check/reset the input power circuit breaker (#1 on Power Distribution Panel). Notify unit maintenance
	Check that the E-Stop (Main Control Panel) is reset (pulled out)	Reset E-Stop
	Check that DC control power circuit breaker CB1 (behind generator control panel) is reset (pushed in)	Reset circuit breaker
	Check that the E-Stop circuit breaker (Power Entrance Panel) is reset (pushed in)	Reset circuit breaker
	Check that the generator DEAD CRANK switch is in NORMAL (behind generator access door accessible from inside the mechanical room)	Place switch in NORMAL
	Check generator battery connections (inside access doors on both sides of generator)	If loose or corroded, notify unit maintenance
Generator cranks but does not start	Check that the generator DEAD CRANK switch is in NORMAL (behind generator access door accessible from inside the mechanical room)	Place switch in NORMAL

**CONTAINERIZED KITCHEN (WITH TRAILER)
TROUBLESHOOTING PROCEDURES (ELECTRICAL SYSTEM)**

Table 1. Troubleshooting Procedures (Electrical System) - Continued

Malfunction	Test or Inspection	Corrective Action
Interior lights do not work	Check generator fuel level	Refill fuel tank
	Check for dirty fuel filter/water separator	Service fuel filter/water separator (Refer to TM 9-6115-642-10)
	Check air cleaner restriction indicator for indication of a clogged air cleaner (inside access door by cook center)	Service air cleaner assembly (Refer to TM 9-6115-642-10)
	Ambient temperature below 40°F	Turn master switch (generator control panel) to PREHEAT for no more than 30 seconds before cranking engine. Refer to TM 9-6115-642-10 Notify unit maintenance
No power at one or more receptacles	No other electrical components operate	See "No Power to Kitchen"
	All other electrical components operate	Check/reset lighting circuit breaker (#19 on Power Distribution Panel) Notify unit maintenance
	No other electrical components operate	See "No Power to Kitchen"
	All other electrical components operate properly	Check/reset ground fault interrupter (on receptacle next to spice rack) Notify unit maintenance

END OF WORK PACKAGE

**CONTAINERIZED KITCHEN (WITH TRAILER)
TROUBLESHOOTING PROCEDURES (MODERN BURNER UNIT)**

Table 1. Troubleshooting Procedures (Modern Burner Unit) – Continued

Malfunction	Test or Inspection	Corrective Action
<p>MBU shuts down during operation</p>	<p>MBU is in cook center</p> <p>MBU is in oven assembly or tray pack heater</p>	<p>Start right-side MBU first</p> <p>Check/connect fuel connection at the base of the mechanical room wall</p> <p>Refer to TM 10-7310-281-13&P for additional troubleshooting guidance for the MBU</p> <p>Notify unit maintenance</p> <p>See “MBU does not start”</p>
	<p>No power at the unit</p> <p>MBU power is on</p>	<p>Check fuel level light on MBU. Refuel if necessary</p> <p>Refer to TM 10-7310-281-13&P for additional troubleshooting guidance for the MBU</p> <p>Notify unit maintenance</p>
<p>MBU fails to fuel</p>	<p>No power to the unit</p>	<p>See “MBU does not start”</p>
	<p>MBU has power but air compressor cannot be heard</p>	<p>Refer to TM 10-7310-281-13&P for additional troubleshooting guidance for the MBU</p> <p>Notify unit maintenance</p>
	<p>MBU power is on and air compressor is running</p>	<p>NOTE: Refueling can take up to 4 minutes for a single MBU, and even longer when more than one is refueling at a time.</p> <p>Ensure that the fuel line to the fuel can is connected, can contains fuel, and valve on fuel can adapter is open</p> <p>Ensure that all hoses are free of leaks and fittings are tight</p> <p>Refer to TM 10-7310-281-13&P for additional troubleshooting guidance for the MBU</p> <p>Notify unit maintenance</p>

END OF WORK PACKAGE

**CONTAINERIZED KITCHEN (WITH TRAILER)
TROUBLESHOOTING PROCEDURES (ENVIRONMENTAL CONTROL UNIT)**

THIS WORK PACKAGE COVERS:

Environmental Control Unit (ECU)

INITIAL SETUP:

CK set up

Maintenance Level

Operator/Crew

ENVIRONMENTAL CONTROL SYSTEM MALFUNCTIONS

Table 1. Troubleshooting Procedures (ECU)

Malfunction	Test or Inspection	Corrective Action
Air conditioners running but are not cooling	Hot air from air ducts	Check ECU control switch position Check/reset ECU circuit breakers (Power Distribution Panel). NOTE: If breakers are cycled, there is a 4-minute built in time delay before cooling will start NOTE: When humidity is high, A/C will work to reduce it, with only a slight reduction in temperature Notify unit maintenance
Heater does not start		Check/reset circuit breaker (#8 on Power Distribution Panel) Notify unit maintenance

END OF WORK PACKAGE

**CONTAINERIZED KITCHEN (WITH TRAILER)
TROUBLESHOOTING PROCEDURES (HAND SINK ASSEMBLY)**

THIS WORK PACKAGE COVERS:

Hand Sink Assembly

INITIAL SETUP:

CK set up

Maintenance Level

Operator/Crew

HAND SINK ASSEMBLY MALFUNCTIONS

Table 1. Troubleshooting Procedures (Hand Sink Assembly)

Malfunction	Test or Inspection	Corrective Action
No hot or cold water	Water pump running Check hoses for kinks, obstructions, leaks, missing washers Supply valve from tank trailer open Pump will not run	Immediately turn water heater OFF (appliance control box) Remove kinks, tighten loose or leaking fittings, repair/replace damaged hose Check/open valve Notify unit maintenance Immediately turn water heater OFF (appliance control box) Check/plug in pump power cord Verify pump switch is ON (appliance control box) Verify appliance control box is plugged in Check/reset pump circuit breaker (appliance control box) Check/reset appliance control box circuit breaker (#24 on Power Distribution Panel) Notify unit maintenance
Low water pressure	Check hoses for kinks, obstructions, leaks, missing washers Supply valve from tank trailer open	Remove kinks, tighten loose or leaking fittings, replace damaged hose Check/open valve

**CONTAINERIZED KITCHEN (WITH TRAILER)
TROUBLESHOOTING PROCEDURES (HAND SINK ASSEMBLY)**

Table 1. Troubleshooting procedures (Hand Sink Assembly) - Continued

Malfunction	Test or Inspection	Corrective Action
No hot water	Water heater plugged in	Notify unit maintenance Check/plug in water heater (appliance control box)
	Water heater switch ON (appliance control box)	Turn water heater switch ON
	Appliance control box plugged in	Plug in appliance control box
	Water heater circuit breaker open (appliance control box)	Check/reset water heater circuit breaker (appliance control box)
	Appliance control box receptacle circuit breaker closed	Check/reset appliance control box circuit breaker (#24 on Power Distribution Panel) Open hot water faucet to purge air and wait 30 minutes for water in tank to heat Notify unit maintenance
Water is still cold after 30 minutes	Water heater switch ON (appliance control box)	Turn water heater switch ON
	Water heater circuit breaker open (appliance control box)	Check/reset water heater circuit breaker (appliance control box) Notify unit maintenance
Water is too hot		Notify unit maintenance to adjust thermostat
Sink drains slowly or does not drain	Check sink trap for clogging. Check drain hoses for kinks, obstructions	Unclog sink trap. Remove kinks or obstructions in drain hoses
No soap from dispenser	Check soap level in dispenser	Refill soap dispenser

END OF WORK PACKAGE

**CONTAINERIZED KITCHEN (WITH TRAILER)
TROUBLESHOOTING PROCEDURES (KITCHEN APPLIANCES)**

THIS WORK PACKAGE COVERS

Kitchen Appliances

INITIAL SETUP:

CK set up

Maintenance Level

Operator/Crew

KITCHEN APPLIANCE MALFUNCTIONS

Table 1. Troubleshooting Procedures (Kitchen Appliances)

Malfunction	Test or Inspection	Corrective Action
Refrigerator does not operate	Power cord plugged in	Plug in power cord
	Refrigerator receptacle circuit breaker tripped	Check/reset circuit breaker (#7 or #9 on Power Distribution Panel)
	Thermostat turned off	Turn on/adjust thermostat Notify unit maintenance
Refrigerator operates but does not cool	Thermostat setting too high	Adjust thermostat to colder setting
	Obstructed air flow at base of unit	Clear airflow obstructions
	Refrigerator door not sealed	Reclose door
	Inspect door gasket for tears, cuts, or other damage	Notify unit maintenance
Mobile warming cabinet does not heat	Power cord plugged in	Plug in power cord
	Warming cabinet receptacle circuit breaker tripped	Check/reset circuit breaker (#16 on Power Distribution Panel)
	Check temperature setting (at bottom front of cabinet)	Adjust temperature setting (at bottom front of cabinet) Notify unit maintenance

**CONTAINERIZED KITCHEN (WITH TRAILER)
TROUBLESHOOTING PROCEDURES (KITCHEN APPLIANCES)**

Table 1. Troubleshooting Procedures (Kitchen Appliances) - Continued

Malfunction	Test or Inspection	Corrective Action
Tray pack heater fan does not work	Heater fan power cord plugged in	Check/plug in power cord (appliance control box)
	Heater fan switch ON (appliance control box)	Turn heater fan switch ON
	Heater fan circuit breaker open (appliance control box)	Check/close circuit breaker
	Appliance control box plugged in	Plug in appliance control box
	Appliance control box receptacle circuit breaker closed	Check/close appliance control box circuit breaker (#24 on Power Distribution Panel)
		Notify unit maintenance
Oven fans do not work	Fan switch(es) ON	Turn fan switch(es) ON
	Oven 120 VAC power cable plugged in	Check/plug in power cable (ceiling raceway)
	Oven receptacle circuit breaker closed	Check/close oven circuit breaker (#21 on Power Distribution Panel)
		Notify unit maintenance

END OF WORK PACKAGE

CHAPTER 4
OPERATOR/UNIT MAINTENANCE PROCEDURES
FOR
CONTAINERIZED KITCHEN (WITH TRAILER) [CK]

**CONTAINERIZED KITCHEN (WITH TRAILER)
SERVICE UPON RECEIPT**

THIS WORK PACKAGE COVERS:

Unpacking, inspection

INITIAL SETUP:

CK packed out

Maintenance Level

Operator/Crew

UNPACKING

The CK is shipped with all components and equipment packed inside the ISO container. To unpack upon receipt, set up the kitchen as described in WP 0006 00.

INSPECTION

Inspect the equipment for damage incurred during shipment. Report any damage on SF 361, Transportation Discrepancy Report.

Check the equipment against the Components of End Item and Basic Issue Items lists (WP 0049 00) to verify that the CK is complete. Report any discrepancies in accordance with DA PAM 738-750.

Check to see that the generator's control panel door and right side door have been removed (they should be, but may not be if the generator has been replaced). The doors may be in position, but their hinges should be unbolted. The control panel door is accessible through the food preparation area wall, and the right side door is accessible through the door next to the cook center. Notify your supervisor if either door has not been unbolted – the generator must be removed from the CK to unbolt them.

Perform Service Upon Receipt for the generator in accordance with TM 9-6115-642-24. Perform Service Upon Receipt for the MBUs in accordance with TM 10-7310-281-13&P.

END OF WORK PACKAGE

**CONTAINERIZED KITCHEN (WITH TRAILER)
PREVENTIVE MAINTENANCE CHECKS AND SERVICES (PMCS)**

THIS WORK PACKAGE COVERS:

Introduction, Preventive Maintenance Checks and Services (PMCS) Procedures

INITIAL SETUP:

CK set up

Maintenance Level

Operator/Crew

INTRODUCTION

Preventive Maintenance Checks and Services (PMCS) are performed to keep the CK and its associated equipment in good operating condition. The checks are used to find, correct, or report problems. Operators and Unit maintenance personnel are to perform the PMCS tasks as shown in the PMCS tables. PMCS are done every day the CK is operated, using the appropriate PMCS table.

Perform all checks and services keeping in mind the following guidelines:

Before you begin using the CK, do **Before Operation PMCS**

While the CK is in use, do **During Operation PMCS**

After using the CK, do **After Operation PMCS**

If you find something wrong when performing PMCS, fix it using troubleshooting and/or maintenance procedures. Pay attention to WARNING and CAUTION statements. A WARNING means someone could be hurt. A CAUTION means equipment could be damaged.

The right-hand column of the PMCS table lists conditions that make the CK not fully mission capable. Write up the faults that cannot be repaired on DA Form 2404 for unit maintenance. For further information on how to use this form, see DA PAM 738-750.

If any tools required to perform PMCS are not listed in the procedures, notify your supervisor.

Refer to TM 9-6115-642-10 for PMCS procedures for the generator.

Refer to TM 10-7310-281-13&P for PMCS procedures for the Modern Burner Unit (MBU).

Refer to TM 9-2330-328-14&P for PMCS procedures for the CK trailer, if applicable.

INSPECTION

Look for signs of trouble. Senses help here. You can feel, smell, hear, or see many problems that can be eliminated before they get worse. Inspect to see that items are in good condition. Are components correctly installed and secured? Is any damage to the frame or components visible? Correct any faults or notify unit maintenance.

**CONTAINERIZED KITCHEN (WITH TRAILER)
PREVENTIVE MAINTENANCE CHECKS AND SERVICES (PMCS)**

LUBRICATION

The only component of the CK requiring scheduled lubrication is the generator set. Refer to LO 9-6115-642-12 and TM 9-6115-642-10 for lubrication procedures. The container winches, door hinges, and corner jacks should be lubricated as necessary in accordance with the PMCS tables.

CLEANING

Proper cleaning of the CK and its components is an integral part of maintenance. It helps prevent possible problems in the future, so make it a habit to clean the CK and its components whenever necessary. Refer to TM 10-7310-281-13&P for proper cleaning procedures for the MBUs.

The generator set can be continuously operated at any time from no load up to and including rated load. At light loads (less than 25% of set rating), an oily residue (unburned fuel oil) may be noticed in the exhaust outlet and around connection joints in the exhaust system. This residue is caused by the inability of the fuel injection system to consistently meter the small amounts of fuel required to operate the generator with a light load. While this condition does not indicate a defect in the fuel system, the oily residue could affect engine performance and create a cosmetic problem on and around the generator set. Operation at rated load will burn off the oily residue in a short time, depending upon the amount present. The muffler may also need to be removed and cleaned if excessive buildup occurs. Increasing the electrical load on the set can prevent this oily residue.

SPECIAL INSTRUCTIONS

It is important for you to know how fluid leakage affects the status of the CK. Following are types/classes of leakage you need to know to be able to determine the status of the CK. Learn these leakage definitions and remember – when in doubt, notify your supervisor.

Class I: Seepage of fluid (as indicated by wetness or discoloration) not great enough to form drops.

Class II: Leakage of fluid great enough to form drops but not enough to cause drops to drip from the item being checked/inspected.

Class III: Leakage of fluid great enough to form drops that fall from the item being checked/inspected.

Equipment with minor fluid leaks (Class I or II) may be operated and is considered fully mission capable (refer to DA PAM 738-750). Of course, you must consider the fluid capacity in the item/system being checked/inspected. When in doubt, notify your supervisor.

When operating with Class I or II leaks, continue to check fluid levels as required by the PMCS tables. Class III leaks should be immediately reported to your supervisor.

**CONTAINERIZED KITCHEN (WITH TRAILER)
PREVENTIVE MAINTENANCE CHECKS AND SERVICES (PMCS)**

THIS SECTION COVERS:

Before Operation Preventive Maintenance Checks and Services (PMCS)

INITIAL SETUP:

Kitchen Set Up for Operation

Maintenance Level:

Operator/Crew

Table 1. Before Operation PMCS for CK

ITEM NO.	INTERVAL	MAN-HOUR	ITEM TO BE CHECKED OR SERVICED	PROCEDURE	EQUIPMENT NOT READY/ AVAILABLE IF:
1	Before		Container	<p>Inspect exterior of container for obvious weld cracks, damage to door hinges, handles, or seals. Check doors for freedom of movement. Lubricate door hinges as necessary (WP 0051 00, Table 1, Item 6.).</p> <p>Inspect cam locks for loose, missing or damaged hardware. Inspect weather seals for deterioration or damage.</p> <p>Inspect bullseye and wing levels for damage</p> <p>Inspect jacks for damage, missing parts, freedom of movement. Lubricate corner jacks as necessary (WP 0051 00, Table 1, Item 4).</p> <p>Inspect stair/ladders and railings for damage, cracked welds.</p> <p>Inspect winches for missing or damaged hardware, freedom of movement. If necessary, apply a light coat of grease to the gears (WP 0051 00, Table 1, Item 4).</p> <p>Inspect winch cables for proper tension, routing and fraying.</p> <p>Inspect inner and outer fabric, floor covering and window screens for holes, tears, or loose seams. Inspect hook and loop closures for damage and proper operation.</p> <p>Inspect tie-down provisions for damage, loose or missing hardware</p>	<p>Container cracked or damaged.</p> <p>Cam locks damaged.</p> <p>Jack cracked or bent, locking pins missing.</p> <p>Any cracked welds.</p> <p>Missing or damaged hardware.</p> <p>Any frayed strand or more than one flat spot on cable.</p> <p>Damaged, loose, hardware missing.</p>

**CONTAINERIZED KITCHEN (WITH TRAILER)
PREVENTIVE MAINTENANCE CHECKS AND SERVICES (PMCS)**

Table 1. Before Operation PMCS for CK - Continued

ITEM NO.	INTERVAL	MAN-HOUR	ITEM TO BE CHECKED OR SERVICED	PROCEDURE	EQUIPMENT NOT READY/ AVAILABLE IF:
2	Before		Mechanical room	Inspect ratchet straps for fraying, cuts, damaged ratchet. Inspect rubber straps for cuts, missing or damaged hooks Inspect intake and exhaust fans for damage, loose or missing parts. Inspect awning assembly for damage.	Damaged straps or ratchets, hooks missing or damaged Missing or damaged hardware.
3	Before		Cook center	Inspect cloth exhaust ducts for damage, proper installation. Inspect base assembly for damage, weld cracks. Inspect fuel line assembly for leaks, damage. Inspect 24 VDC power cable assembly for frayed wires, damaged connectors. Inspect ventilation hood assembly for loose, missing or damaged hardware. Check fans for proper operation. Inspect grease filters and filter frame for loose, missing or damaged hardware or cracked welds. Check for grease accumulation. Clean filters as necessary.	Any fuel leak. Frayed wire or damaged connector. Fans inoperable.
4	Before		ECU filters	Inspect griddle, steam table, cook pot cradles and adapters, base rack, burner rack for cracks and damage. Inspect filters for damage, cleanliness. Remove and clean as necessary	Damage, cracked weld.
5	Before		Oven assembly	Inspect oven and base cabinet for damage, weld cracks, missing parts. Inspect fuel line assembly for leaks, damage. Inspect 24 VDC and 120 VAC power cables for frayed wires, damaged connectors.	Any fuel leak. Frayed wire or damaged connector.

**CONTAINERIZED KITCHEN (WITH TRAILER)
PREVENTIVE MAINTENANCE CHECKS AND SERVICES (PMCS)**

Table 1. Before Operation PMCS for CK - Continued

ITEM NO.	INTERVAL	MAN-HOUR	ITEM TO BE CHECKED OR SERVICED	PROCEDURE	EQUIPMENT NOT READY/ AVAILABLE IF:
6	Before		Tray Pack Heater	Inspect tray pack heater for loose, missing or damaged hardware or cracked welds.	Any water leak.
7	Before		Hand Sink Assembly	Inspect heater fan assembly for damage, missing or damaged power cord. Inspect sink and cabinet for damage, loose or missing hardware. Inspect faucet, drain trap, and water lines for damage, missing parts.	Power cord missing or damaged.
8	Before		Hose assemblies	Inspect water pump and water heater for damage, missing or damaged power cord. Inspect water supply and drain hoses for damage to hoses or connectors, missing washers.	Power cord missing or damaged.
9	Before		Mobile Warming Cabinet	Inspect cabinet for damage. Inspect power cord for fraying or damaged connector.	Power cord missing or damaged.
10	Before		Refrigerators	Inspect cabinet for damage. Inspect power cord for fraying or damaged connector. Inspect door seal for damage and proper seal contact.	Damaged door seal. Power cord missing or damaged.
11	Before		Light fixtures	Inspect all light fixtures for damage, broken or missing bulbs. Inspect removable lights for frayed power cord, damaged connector. Turn on lights and check for proper operation in both normal and blackout modes. Using the test switch on the fixture, check for proper operation of the emergency light.	Frayed wire or damaged connector.
12	Before		Miscellaneous	Inspect mobile storage cabinets and pan rack for any loose, missing or damaged hardware, cracked welds, damaged or missing casters.	

**CONTAINERIZED KITCHEN (WITH TRAILER)
PREVENTIVE MAINTENANCE CHECKS AND SERVICES (PMCS)**

Table 1. Before Operation PMCS for CK - Continued

ITEM NO.	INTERVAL	MAN-HOUR	ITEM TO BE CHECKED OR SERVICED	PROCEDURE	EQUIPMENT NOT READY/ AVAILABLE IF:
				<p>Inspect prep/serving tables and drawer assemblies for damage, missing parts.</p> <p>Check fire extinguishers for correct charge. Check inspection date on tag. Be sure to check the extinguisher in the mechanical room.</p> <p>Check first aid kit for expiration date, missing items.</p>	<p>Discharged or overdue for inspection.</p>

**CONTAINERIZED KITCHEN (WITH TRAILER)
PREVENTIVE MAINTENANCE CHECKS AND SERVICES (PMCS)**

THIS SECTION COVERS:

During Operation Preventive Maintenance Checks and Services (PMCS)

INITIAL SETUP:

Kitchen Set Up/Operating

Maintenance Level:

Operator/Crew

Table 2. During Operation PMCS for CK

ITEM NO.	INTERVAL	MAN-HOUR	ITEM TO BE CHECKED OR SERVICED	PROCEDURE	EQUIPMENT NOT READY/ AVAILABLE IF:
1	During		Cook center	Monitor ventilation supply and exhaust fans for proper operation. Monitor MBUs for proper operation. Monitor grease filters for grease buildup. Remove and clean filters as necessary. Monitor grease cup and grease pan for grease accumulation. Empty and clean as necessary.	Ventilation or exhaust fan inoperable. MBU inoperable.
2	During		Oven assembly	Monitor MBU and oven fans for proper operation.	MBU or oven fan inoperable.
3	During		Tray pack heater	Monitor MBU and heater fan for proper operation.	MBU or heater fan inoperable.
4	During		Hand sink assembly	Monitor water pump and water heater for leaks and proper operation.	Pump or water heater leaking or inoperable.
5	During		Mobile warming cabinet	Monitor cabinet for proper operation and temperature control.	Cabinet will not maintain temperature.

**CONTAINERIZED KITCHEN (WITH TRAILER)
 PREVENTIVE MAINTENANCE CHECKS AND SERVICES (PMCS)**

Table 2. During Operation PMCS for CK – Continued

ITEM NO.	INTERVAL	MAN-HOUR	ITEM TO BE CHECKED OR SERVICED	PROCEDURE	EQUIPMENT NOT READY/ AVAILABLE IF:
6	During		Refrigerators	Inspect door for proper seal contact. Check inside thermometer for proper temperature. Check operation of interior light.	Door not properly sealing. Will not maintain proper temperature.
7	During		ECU	Monitor for proper operation and excessive or unusual noise. Inspect filters and clean as necessary.	

**CONTAINERIZED KITCHEN (WITH TRAILER)
PREVENTIVE MAINTENANCE CHECKS AND SERVICES (PMCS)**

THIS SECTION COVERS:

After Operation Preventive Maintenance Checks and Services (PMCS)

INITIAL SETUP:

Kitchen Set Up/Not Operating

Maintenance Level:

Operator/Crew

Table 3. After Operation PMCS for CK

ITEM NO.	INTERVAL	MAN-HOUR	ITEM TO BE CHECKED OR SERVICED	PROCEDURE	EQUIPMENT NOT READY/ AVAILABLE IF:
1	After		Container	Inspect shelter fabric, floor covering and screens for holes, tears, or loose seams. Inspect hook and loop closures for damage and proper operation. Inspect doors for damage to hinges, handles, or seals. Inspect stair/ladders and railings for damage, cracked welds.	Damage, cracked weld. Any leak. Pump or water heater inoperable. Door not properly sealing.
2	After		Cook center	Inspect filters for grease accumulation. Remove and clean as necessary.	
3	After		ECU filters	Inspect filters for damage, cleanliness. Remove and clean as necessary.	
4	After		Oven assembly	Inspect oven for cleanliness. Clean as necessary.	
5	After		Tray pack heater	Inspect interior of heater for cleanliness. Clean as necessary.	
6	After		Hand sink assembly	Inspect cabinet, sink, faucet for damage, evidence of leakage.	
7	After		Refrigerators	Inspect door seal for proper contact.	

END OF WORK PACKAGE

**CONTAINERIZED KITCHEN (WITH TRAILER)
UNIT MAINTENANCE PROCEDURES**

SHELTER ASSEMBLY**THIS SECTION COVERS:**

Inspect, Replace, Repair

INITIAL SETUP:

Winch Removal/Replacement procedures are dependent on winch failure condition/position. CK Setup Procedures are altered as described later in this Work Package. For all other procedures, CK is set up for operation.

Maintenance Level**Unit**

Tool Kit, General Mechanic's (WP 0052 00, Table 1, Item 1)
Protective Leather Safety Gloves

GENERAL

This procedure contains information and instructions for inspecting and making repairs to the Shelter Assembly. Refer to WP 0034 00 for repair parts information.

INSPECT

Safety Strap: Follow the Shelter Expansion procedure in WP 0006 00 to lower the applicable wing until the orange safety strap is almost tight. The orange safety strap is to be replaced if it is broken, frayed at the edges or it is evident that the strap will not support the weight of the shelter floor as it is being lowered. There is no repair for the safety strap. It must be replaced. Refer to the following section for the replacement procedure.

Winch Assembly and Cable: Follow the Shelter Expansion or Wing Closure procedure as applicable to lower or raise each wing. The winch should provide a smooth and even cranking operation. If a rough, intermittent, erratic or binding operation occurs, a determination of whether the fault is in the cable or winch assembly should be made. Open the bottom winch assembly access panel located inside the CK and to the left of the personnel access door. Check that the winch cable is evenly wound on the winch cable reel. Check the winch cable at each end of the side wings where the cable is visible. Look for kinks or broken wires on the cable. A wire is the smallest individual metal cord that, when combined with a specific number of other wires, constitutes a strand (see Figure 1).

**CONTAINERIZED KITCHEN (WITH TRAILER)
UNIT MAINTENANCE PROCEDURES**



Figure 1. CK Winch Cable

The winch cable should be replaced if any of the following conditions exist:

- a) There are more than three randomly distributed broken wires in one rope lay (see Figure 1). There are three broken wires in one strand in one 10-foot length.
- b) There is one broken wire from an inner strand that is not specifically visible externally, but can be identified as it protrudes or loops out of the wire rope structure.

Refer to a following section for the cable replacement procedure.

If the winch cable is not binding or broken, the winch assembly may be defective. In normal operation, the winch will make a clicking sound when the winch handle is rotated clockwise (raise direction). No clicking sound will be heard when the winch handle is rotated counterclockwise (lowering direction). Operation other than this indicates a malfunctioning winch assembly and must be replaced.

NOTE

The winch handle may have to be turned up to 10 clockwise revolutions before a clicking sound is heard. This is to ensure the winch handle socket is fully secured. However, if after rotating the handle clockwise for at least 10 revolutions a clicking sound is not heard, the winch assembly should be replaced.

Refer to a following section for the winch replacement procedure.

Shelter and Awning Fabric: Any tears in the fabric or awning that permit water to penetrate the shelter require maintenance. Follow the repair procedure described in the Repair section at the end of this work package.

Exterior Drain Hose: Locate the source of drain hose leakage. If at the connector, check the connector gasket. If warped or cut, replace the gasket. If the leak is in the hose part of the assembly, the hose assembly will need to be replaced.

**CONTAINERIZED KITCHEN (WITH TRAILER)
UNIT MAINTENANCE PROCEDURES**

Tie-down Provision: Inspect the tie-down provisions in the shelter floor for tightness, damage, or corrosion. If damaged, refer to the replacement procedures in the following section.

REPLACE

Safety Strap: The side wing of the shelter must be in the lowered position to replace a safety strap. Unbolt the strap from the shelter and retain the hardware. Install the new strap using the retained hardware .

Tie-down Provision: Remove and discard the tie-down provision and the three attaching screws (the replacement tie-down comes with new screws). Remove any dried caulking compound from the recess in the floor, being careful not to damage the flooring material or the screw holes.

Apply caulking compound (WP 0051, Table 1, Item 10) to the underside of the new tie-down provision flange, around the outer edge of the flange, and inside the three screw holes.

CAUTION

The replacement tie-down provision must be oriented in the proper direction (see Figure 2). Failure to observe this caution may result in equipment damage from tie-down provision failure.

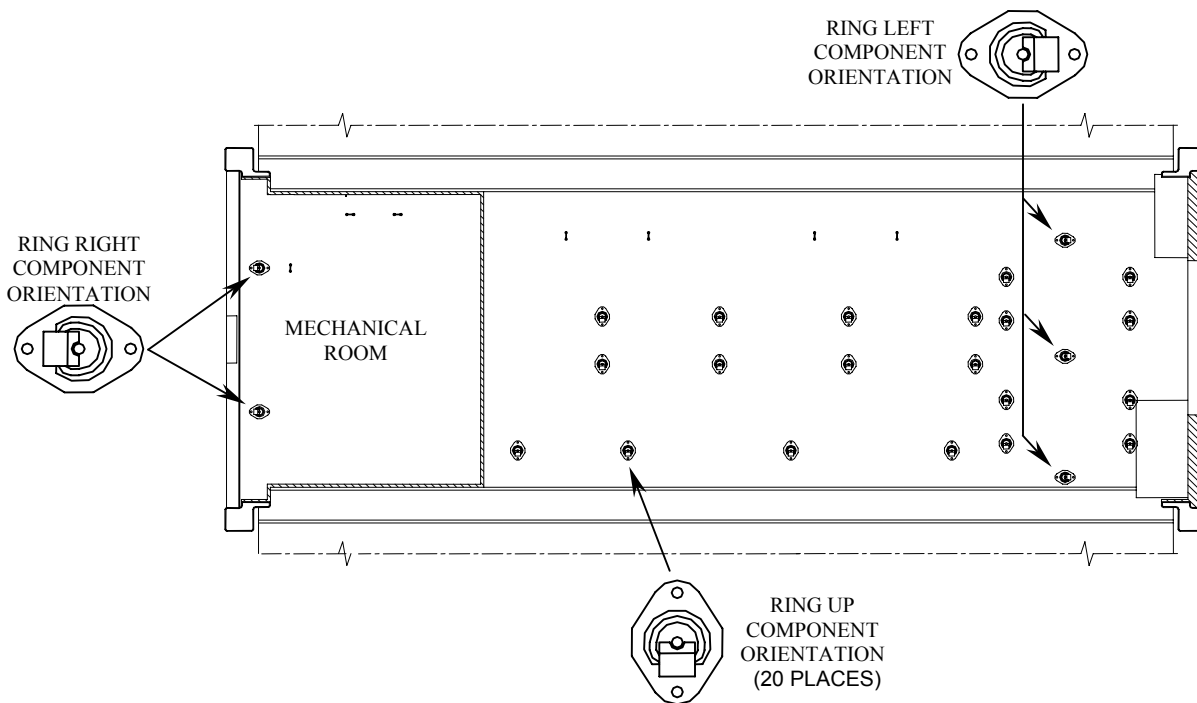

Figure 2. Tie-down Provision Orientation.

Place the new tie-down provision in the floor recess and attach it using the three new screws. Use the shortest screw in the center hole. Be careful not to over-tighten the screws.

**CONTAINERIZED KITCHEN (WITH TRAILER)
UNIT MAINTENANCE PROCEDURES**

Winch Cable Removal: The side wing of the CK must be in the lowered position to remove/replace the winch cable. If the cable is badly damaged, other support for the wing shall be used as a backup for the winch cable. Follow the CK setup procedures to open the side wing.

CAUTION

A damaged cable may break and let the wing fall without warning causing injury to personnel and damage to equipment. Use nylon straps and appropriate lifting device to support the wing. Do not use the prongs on a forklift as support as they may damage the wing.

WARNING

Use protective safety leather gloves when handling the winch cable.

Winch Cable Removal:

NOTE

Two people are required for the Winch Cable Removal Procedure.

Open the top and bottom access panels for the cable pulleys and winch assembly, located inside the CK and to the left of the personnel access door. One person will use the winch handle to unwind the winch cable from the reel by turning the handle in the direction of lowering the wing as indicated by the decal on the winch handle socket. A second person outside (on the ground at the end of the lowered wing nearest the personnel door) will pull and keep tension on the cable until it is wound off the reel. Coil the cable on the ground as neatly as possible to avoid kinking the cable. A cable keeper attaches the cable to the winch reel. Turn the winch handle and position the reel so the cable keeper nuts are at the top.

NOTE

Observe the routing of the cable to aid in reassembly.

Remove the cable keeper nuts on the winch reel. Pull the cable free from the reel and have the person outside the CK slowly pull the cable outside the CK while guiding the cable through the cable pulleys.

One person moves to the Mechanical Room end of the wing and pulls the cable from the wing floor cable tube. The other person (at the opposite end) guides the cable through the wing floor cable tube. Coil the cable on the ground as neatly as possible by the Mechanical Room.

**CONTAINERIZED KITCHEN (WITH TRAILER)
UNIT MAINTENANCE PROCEDURES**

From inside the Mechanical Room, locate the black plastic plug (opposite of where the cable enters from the outside) in the upper back corner of the Mechanical Room. Remove the plastic plug, grasp the cable ferrule end with long nosed pliers and pull it free of the CK wall. A person outside the CK should guide the cable as it is pulled from the inside the Mechanical Room. Coil the cable on the Mechanical Room floor.

Winch Cable Replacement:**NOTE**

Two people are required for the Winch Cable Replacement Procedure.

From inside the Mechanical Room, insert the free end of the new cable (opposite the cable ferrule) into the cable hole. A second person, outside the CK, assists in pulling the cable through the Mechanical Room wall. Avoid twisting or kinking the new cable and neatly coil the cable on the ground by the Mechanical Room. The cable should be completely pulled through until the cable ferrule is seated in the holder. Push the free end of the cable through the wing floor cable tube from the Mechanical Room end of the floor wing. When the end of the cable is through the tube and appears out the opposite end, it should then be pulled while being guided from the Mechanical Room end to avoid kinking the cable. Pull the cable completely through the tube and neatly coil the cable on the ground next to the CK.

From outside the CK, push the free end of the cable into the cable passageway at the top of the CK and over the cable pulleys. The cable may have to be guided through the pulley assembly by someone inside the CK. Pull the cable down to the winch assembly. Wind the cable onto the winch reel (as previously noted during disassembly) for a full turn and secure the cable to the reel using the cable keeper.

With one person inside the CK guiding and maintaining tension on the cable, the second person uses the winch handle to take up any excess cable. The handle should be turned as if raising the wing. The cable should be wound smoothly and evenly on the winch reel. Observe that the ferrule on the cable end in the mechanical room is securely seated, and replace the plastic plug. Raise and lower the wing 2 or 3 times to ensure the cable operates smoothly.

CK Setup Procedures For Winch Removal/Replacement:

There are three possible CK positions involving winch failure. In some positions, the CK setup procedures must be altered prior to winch removal/replacement; in other cases, direct winch removal/replacement will be possible. Regardless of the CK position, access to the winch assembly is through the winch access panel. Winch failure can occur in relation to the following three CK positions:

1. The CK is in the open position. The CK setup procedures should already be completed and both CK wings are down and supported by jacks. If there is any equipment located in the area around the winch access panel, it should be moved. The Winch Removal/Replacement procedures can be implemented.

**CONTAINERIZED KITCHEN (WITH TRAILER)
UNIT MAINTENANCE PROCEDURES**

2. The CK is completely closed or in the nearly closed position. The CK is nearly closed when the wing is supported in place by only a safety strap; it is completely closed when the wing is fastened shut by the cam locks. In either the nearly closed or completely closed position, each item inside the kitchen is positioned in its pack out location.

WARNING

If the CK is in the nearly closed position, use cargo straps, in addition to safety straps, to secure the CK wing on the damaged/broken winch side.

The CK setup procedure is different depending on which of the following two CK winch assemblies fail:

- a) Winch assembly failure occurs on the preparation side of the CK. The normal CK setup procedures should be followed resulting in the serving line side of the shelter being lowered and jacks positioned in place. Next, the refrigerators should be moved to the serving line side of the kitchen. After the refrigerators have been moved, there should be enough space to allow for access to the winch assembly access panel. The Winch Removal/Replacement procedures can be implemented.
 - b) Winch assembly failure occurs on the serving line side of the CK. The set-up procedure of the kitchen must be done out of sequence. The serving line wing of the CK must be secured in place by use of either the cam locks or combination of safety and cargo straps. The preparation side wing of the CK must be lowered and supported by jacks. The refrigerators must be carefully moved into the preparation side wing of the CK. Care must be taken not to tear the fabric wall while moving the refrigeration units. Once the refrigerators are moved, the Winch Removal/Replacement procedures can be implemented.
3. The CK is in an intermediate wing position and gravity has caused the wing to fall down past horizontal (this is not a catastrophic failure of the CK). A forklift may be needed to carefully lift the wing up so that jacks can be installed to support the wing.

NOTE

Use care when positioning the fork prongs under the wing as to not cause damage. With the wing supported, normal CK setup procedures should be completed and the winch assembly replaced.

Winch Removal/Replacement Procedures:**Winch Removal:**

1. Before removing the winch, make sure the wing of the Containerized Kitchen (CK) is supported either by jacks or safety straps.

**CONTAINERIZED KITCHEN (WITH TRAILER)
UNIT MAINTENANCE PROCEDURES**

WARNING

Use protective safety leather gloves when handling the winch cable.

NOTE

Two people are required for the Winch Removal Procedure.

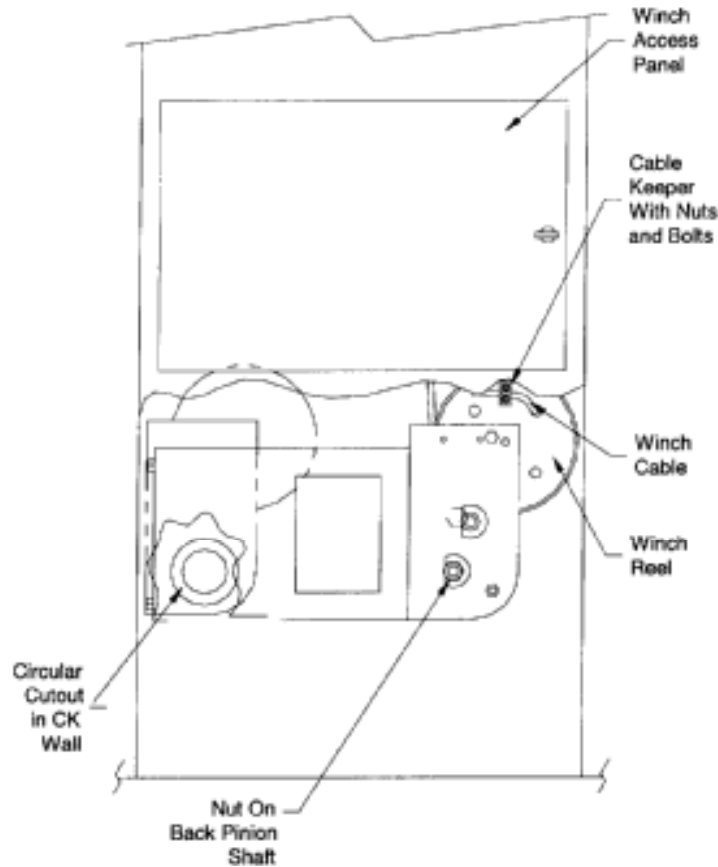

Figure 3. Preparation Side CK Winch Installed/Cable

2. Open the bottom access panel for the winch assembly, located inside the CK and to the serving side of the personnel access door. With one person on the outside of the CK using the winch handle and another person on the inside of the CK applying tension to the cable, unwind the winch cable from the reel by turning in the direction of lowering the wing. On completion of the procedure, remove the winch handle and secure it.

**CONTAINERIZED KITCHEN (WITH TRAILER)
UNIT MAINTENANCE PROCEDURES**

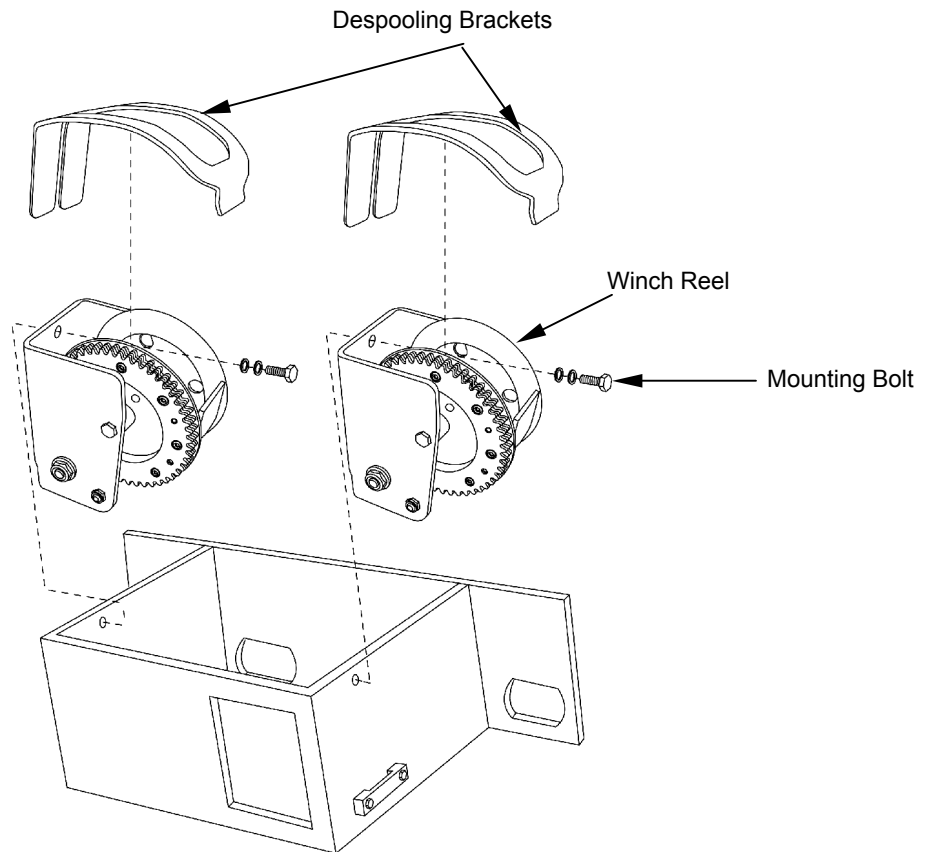

Figure 4. Winch Installation (Cable Omitted For Clarity)

NOTE

Some CK units do not have the despooling bracket installed. If the CK unit has a despooling bracket, you will need a socket extension.

3. Through the inside winch access panel, using a 9/16" socket remove the winch mounting bolt, flat washer, lock washer, and the despooling bracket.
4. Remove the winch assembly by pushing the top of the winch assembly towards the outside wall, and pull the bottom part of the winch assembly toward the CK interior as you are lifting up the winch assembly.
5. Place the winch assembly on the CK floor. Remove winch handle, winch socket, and winch socket hex screw and retain for installation of the replacement winch. Use a 7/16" socket on the hex head screw, while securing the pinion shaft to hold it steady (refer to Figure 3). Twist off the winch socket and retain for installation on the new winch assembly.

NOTE

There's a spacer inside the winch socket, make sure to retain it.

**CONTAINERIZED KITCHEN (WITH TRAILER)
UNIT MAINTENANCE PROCEDURES**

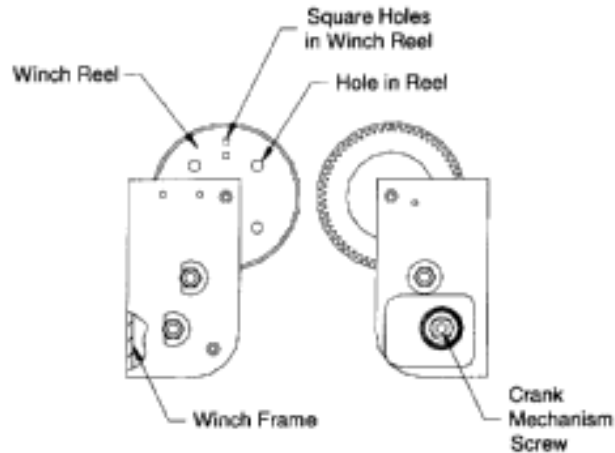

Figure 5. Winch Uninstalled (Socket Installed)

NOTE

Observe the routing of the cable to aid in reassembly.

6. Refer to Figure 3. Manually unwind the cable completely from the reel and expose the hex nuts. Remove the two hex nuts from the cable keeper that secures the winch cable to the outside of the reel. Retain nuts, carriage bolts and cable keeper. Pull the winch cable from the winch reel and place cable on the floor of the CK. Do not allow the cable to become tangled or kinked.

Winch Replacement:

WARNING

Use gloves when handling winch cable.

NOTE

Two people are required for the Winch Replacement Procedure.

1. Place the winch on the floor of the CK. Place the hex screw inside the winch socket making sure it goes through the spacer, and screw on the winch handle socket. Secure the winch handle socket with the hex screw while holding the pinion shaft steady. Insert the winch handle and check for the following: A clicking sound should be heard when the handle is rotated clockwise. No clicking sound should be heard when the crank is rotated counterclockwise. Operation other than this indicates a bad winch and should be returned or replaced. Remove the winch handle from the socket.

NOTE

Be sure to fully secure the winch socket. The winch socket has to be fully secured in order to hear the clicking sound when the winch is rotated clockwise.

CONTAINERIZED KITCHEN (WITH TRAILER) UNIT MAINTENANCE PROCEDURES

2. Route the cable around the reel as previously noted when removed. Thread the winch cable through the round hole prior to the cable keeper mounting holes in the winch reel. Place the cable end at least 1" past the two square holes in the reel. When cable is in proper location, replace the cable keeper and secure it with two bolts and two hex nuts.
3. Place the winch assembly back into the wall of the CK. Avoid kinking or pinching the winch cable. Push the winch assembly into place, making sure the tab on the winch frame slides into the attachment bracket and the winch socket is in the wall cutout.

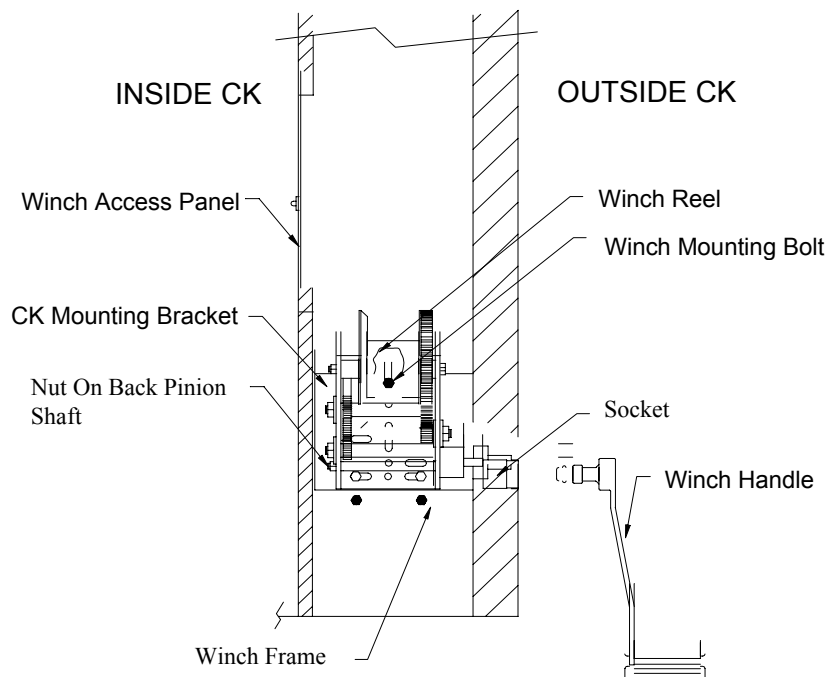

Figure 6. Winch Installation (Cable And Despooling Bracket Omitted For Clarity)

4. Replace the bolt, flat washer, and lock washer that attach the winch frame to the mounting bracket on the CK. Temporarily tighten the bolt just enough to hold the winch in place. Install the despooling bracket and fully tighten the bolt.
5. While one person inside is holding the cable to provide tension and guiding the winch cable around the winch reel to assure proper cable alignment around the winch reel, another person outside is cranking the winch handle. The cable should be wound smoothly and evenly until the cable is taut. Secure and close the winch access panel.
6. To assure proper operation and tension on the winch cable, the CK wing should be raised and lowered (or vice versa, depending on the position of the wing) 2 or 3 times. Refer to WP 0006 00 for a description of raising/lowering the wing.

CONTAINERIZED KITCHEN (WITH TRAILER) UNIT MAINTENANCE PROCEDURES

Exterior Drain Hose Replacement: If a quick-disconnect coupling is damaged or the hose is cut or cracked, no repair is possible. The hose assembly must be replaced. If a gasket is damaged, remove it from the coupling using long nose pliers and replace it with a new one.

Fabric Side Removal/Replacement Procedures:

NOTE

For removal/replacement of the fabric side, three to four soldiers are required. The following tools (if available) will greatly ease the time required for the replacement of the fabric sides: 4 punches or awls, and a screwdriver or screw gun with a #3 Philips Head Bit.

Fabric Side Removal:

1. The shelter wing (1) (see Figure 7) must be fully lowered and supported by wing jacks. If the CK is packed out, all appliances may remain where they are tied down. If the CK is set-up for operation, all appliances must be moved to the opposite wing. Remove the shelter arch components from the fabric side to be replaced. Refer to WP 0006 00 and only follow the processes to remove the shelter arch components. Place the frame components inside the shelter out of the way.

2. Starting at either end and along the edge of the shelter wing (1) (see Figure 7), remove and retain the screws and mounting strips that secure the fabric to the wing. Remove only the top-mounting strip along the wing that secures the fabric, not the lower strip that secures the black rubber seal. Repeat the process along the entire length (2) (see Figure 7) and ends of the CK wing. After all hardware has been removed, pull the fabric away from the wing edge. The fabric may be bonded with sealant to the wing edge; if this is apparent, some force may be needed to pull the fabric loose from the wing edge.

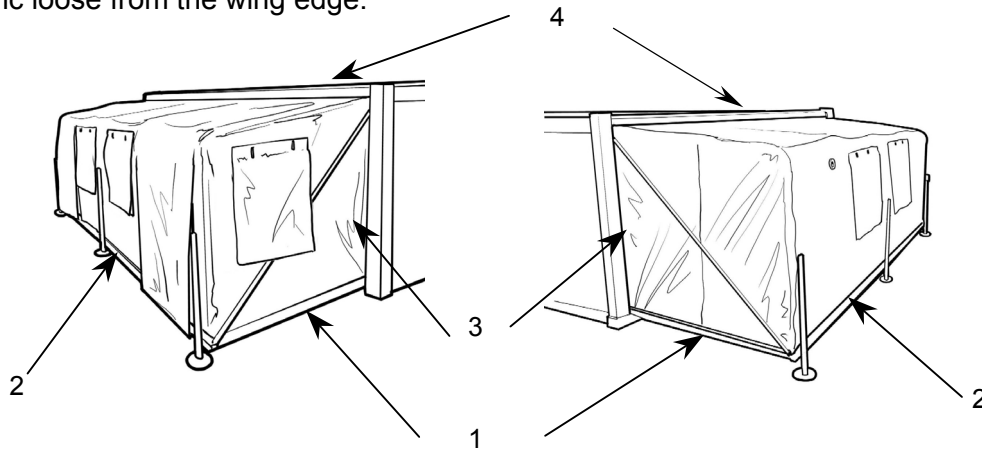

Figure 7. Fabric Side Removal/Replacement

**CONTAINERIZED KITCHEN (WITH TRAILER)
UNIT MAINTENANCE PROCEDURES**

3. Roll the fabric along its length (2) (see Figure 7) until the fabric roll is as close to the shelter as possible and still be lying on the wing floor where the wing is hinged to the shelter. Starting at one end of the shelter, remove and retain the machine screws and mounting strips at the ends (3) (see Figure 7) and along the top (4) (see Figure 7) of the shelter. After all hardware has been removed, pull the fabric away from the shelter and remove the fabric side. The fabric may be bonded with sealant to the shelter edge; if this is apparent, some force may be needed to pull it loose from the shelter. Fold the fabric for disposal.

Fabric Side Replacement:

1. In an area free of rocks and other debris that may damage the fabric, completely unfold the replacement fabric side, white side up. Determine the long edge of the fabric side that is to be attached along the top of the shelter. The long edge (2) (see Figure 7) of the fabric that is closest to the doors or windows attaches to the wing edge. The opposite long fabric edge attaches to the shelter top (4) (see Figure 7). First fold this top edge in half and mark the center of the fabric with a black marker. Unfold the fabric with the white side up. Fold the long edge of the fabric that is closest to the windows and doors and will attach to the wing. Mark the center of the fabric with a black marker. Unfold the fabric with the white side up.
2. Starting at the long edge (2) (see Figure 7) of the fabric closest to the windows or doors tightly roll the fabric up lengthwise. Window flap or door flap will be hanging toward the edge that you roll. Place the rolled up fabric side on the shelter wing (1) (see Figure 7) and as close to the shelter as possible.
3. Pull the top edge of the fabric up to the top edge of the shelter. The fabric should unroll on the wing as the fabric is pulled up. Most of the weight of the fabric will still be on the wing and most of the fabric will still be rolled up. Align the fabric center mark that was located previously with the shelter middle arch cup.
4. Two soldiers are required to support the weight of the fabric, position the fabric and mounting strips while a third soldier, begins installation of the hardware.

NOTE

It is very important to correctly line up the middle of the fabric to the middle of the shelter. If the fabric is not aligned correctly, the fabric will not fit or seal properly to the shelter. Make sure that the fabric is not bunched-up or overlapped.

Before securely attaching the fabric, make sure the fabric side is not inside out or upside down. This is determined by checking: a) that the white side of the fabric is visible from the interior of the CK and the green/tan side is visible from the exterior, and b) that the door or window flaps attach at the top and the flaps can be rolled up from the bottom.

**CONTAINERIZED KITCHEN (WITH TRAILER)
UNIT MAINTENANCE PROCEDURES**

5. Position the mounting strip on top of the fabric beginning at one end of the shelter and extending to the center of the shelter. When you are installing the mounting strip, position the fabric so that the fabric edge extends $\frac{1}{2}$ inch past the mounting strip.
6. Start in the center of the shelter and use an awl to push several holes in the fabric. Start the screws in the holes after the holes have been punched. Do not tighten screws until all holes in the fabric have been punched and screws started. Continue to the end of the mounting strip. Make sure that the fabric is not bunched-up or overlapped. Reposition the fabric if necessary.
7. Install the second mounting strip next to the strip already installed. Following the same procedures for securing the previous mounting strip, continue to the end of the shelter. Securely tighten all screws in both mounting strips.
8. Stretch the fabric over the curved corner plate at the end top of the shelter. Repeat the procedure to attach the curved mounting plate at the opposite end of the shelter.
9. Repeat the procedure for attaching the fabric and mounting strips and continue down the both ends of the shelter. Make sure that the fabric is not bunched-up or overlapped. Reposition the fabric if necessary. Any excess fabric should end up in the bottom corner of the shelter where the wing is hinged.
10. Unroll the rest of the fabric and pull out over the long edge of the shelter wing. Center the long portion of the fabric edge along this long edge of the wing. Align the center mark on the fabric with the center arch cup on the wing. Position the mounting strip on top of the fabric beginning at the either end of the shelter wing and extending to the center of the wing.
11. The fabric should only touch the edge of the rubber weather strip along the length of the wing edge. Unlike all the other shelter mounting surfaces, the fabric should not extend past the mounting strip on the wing edge, because it will interfere with the weather stripping.
12. Start in the center of the shelter and use an awl to push several holes in the fabric. Start the screws in the holes after the hole has been punched. Make sure that the fabric is not bunched-up or overlapped. Any excess fabric should end up in the corner of the shelter where the wing is hinged. Reposition the fabric, if necessary.
13. Repeat the procedure for positioning the fabric and mounting strip for the opposite end of the wing. Securely tighten all screws in both mounting strips.
14. Repeat the procedure for attaching the fabric and the mounting strips along either of the short edges of the wing. Start at the corner of the wing where the fabric is already attached. Again make sure that the fabric is not bunched-up or overlapped. Any excess fabric should end up in the corner of the shelter where the wing is hinged. Repeat the process on the other end of the wing.
15. Check that all fabric mounting hardware has been properly installed and all screws tightened.

**CONTAINERIZED KITCHEN (WITH TRAILER)
UNIT MAINTENANCE PROCEDURES**

16. After the fabric installation is complete, install the shelter arch components and check the alignment of the fabric side.

REPAIR

Exterior Drain Hose Coupling Repair: If the coupling gasket is damaged, remove it from the coupling using long nose pliers and replace it with a new one.

Fabric Repair, Outside Surface or Awning: To repair a tear in the outer fabric or awning, use the fabric repair kit. Cut a patch of at least a one-inch greater size than the tear in all directions. Round the corners of the patch. Thoroughly clean the cover surface and roughen it with an abrasive file.

Apply an even coat of vinyl cement to both surfaces and let them dry for 2 to 5 minutes.

With an assistant supporting the vinyl from inside the shelter, press firmly to bond the surfaces. Allow twenty-four hours at 60 °F or more to cure before folding up the cover.

Fabric Repair, Inside Surface: With gray duct tape (or equivalent), cover the tear in the insulation area or tape a patch in place covering all edges. Cut a strip of tape longer than the tear in the inner liner.

Press one long edge of the tape to the area of the tear ensuring that the ends of the tape extend past the end of the tear on both ends. Close the tear and press the other side into the tape with an assistant on the outside providing support. The final appearance on the inside should be a nearly straight line following the original tear.

END OF WORK PACKAGE

**CONTAINERIZED KITCHEN (WITH TRAILER)
UNIT MAINTENANCE PROCEDURES**

MECHANICAL ROOM**THIS SECTION COVERS:**

Inspect, Test, Replace

INITIAL SETUP:

CK set up for operation

Maintenance Level

Unit

Tools and Special Tools

Tool Kit, General Mechanic's (WP 0052 00, Table 1, Item 1)

GENERAL

This procedure contains information and instructions for inspecting and making repairs to various components in the CK Mechanical Room. Refer to WP 0035 00 for repair parts information. Electrical power components are included in the Electrical System Unit Maintenance Procedures. Fuel line and electrical cable procedures for components inside the kitchen area are included in the applicable Unit Maintenance Procedures for the individual component.

INSPECT

Inspect fuel lines for damaged connectors and lines.

Inspect 24 VDC power cables for frayed insulation and damaged connectors.

Inspect cloth exhaust ducts for cuts or tears.

Inspect air conditioner vibration mounts for damage or deterioration.

TEST

Fuel Lines: Refer to the troubleshooting procedures in the MBU manual to determine if the problem with the MBUs is caused by a fuel problem. If the problem is lack of fuel, check the connections at the fuel source, that the proper fuel is being used, and that the vent valve on the fuel can adapter is open. Check the fuel line connections at the fuel line tee on the left side of the Mechanical Room wall behind the generator for any signs of fuel leakage.

24 VDC Electrical Cable: Refer to the troubleshooting procedures in the MBU manual to determine if the problem with the MBUs is caused by an electrical problem. If there is an electrical problem, remove a 24 volt connector from any of the MBUs and check for 24 VDC. If there is no voltage, check the switch position on the MBU Converter (pulled forward position away from the wall) and the power connector. Remove the 24 VDC power connectors at the MBU Converter and check for 24 VDC. If the voltage is not 24 VDC, replace the MBU Converter. See the replacement procedure in the following section.

If the 24 VDC at the MBU Converter is correct, check the 24 VDC wiring to the kitchen area.

**CONTAINERIZED KITCHEN (WITH TRAILER)
UNIT MAINTENANCE PROCEDURES**

Electrical Power: See Power Entrance Panel: WP 0026 00

Cook Center Fan Assemblies: Rotate the fan control knob on the kitchen wall to the full clockwise position. To check the intake fan, remove the filter located on the air conditioning side of the Mechanical Room. Remove the cover from the fan and check the voltage. It should measure approximately 220 VAC. As the fan control is rotated counterclockwise position the voltage will decrease. If voltage is not present, check the circuit breaker and the voltage at the circuit breaker panel. If 220 VAC is present, the fan assembly needs to be replaced. Refer to the replacement procedure in the next section for access to the fan.

To check the exhaust fan, remove and retain the four mounting bolts on the exhaust duct and remove the fan assembly. Follow the procedure above to check fan operation.

Environmental Control Unit (ECU): The ECU is controlled from the wall switch in the food preparation area. If the ECU is not cooling or warming properly, check that the ECU Mode Switch in the food preparation area is set to the proper position. At the ECU Control Box located on the Mechanical Room wall behind the generator, next to the air conditioners, check the power supply output voltage at P5 (5 VDC) and P6 (12 VDC) as shown in Figure 1. If the voltage is not correct, replace the power supply. If the voltage is correct, perform the following diagnostic check to isolate the problem to an individual ECU and verify operation of the ECU control card.

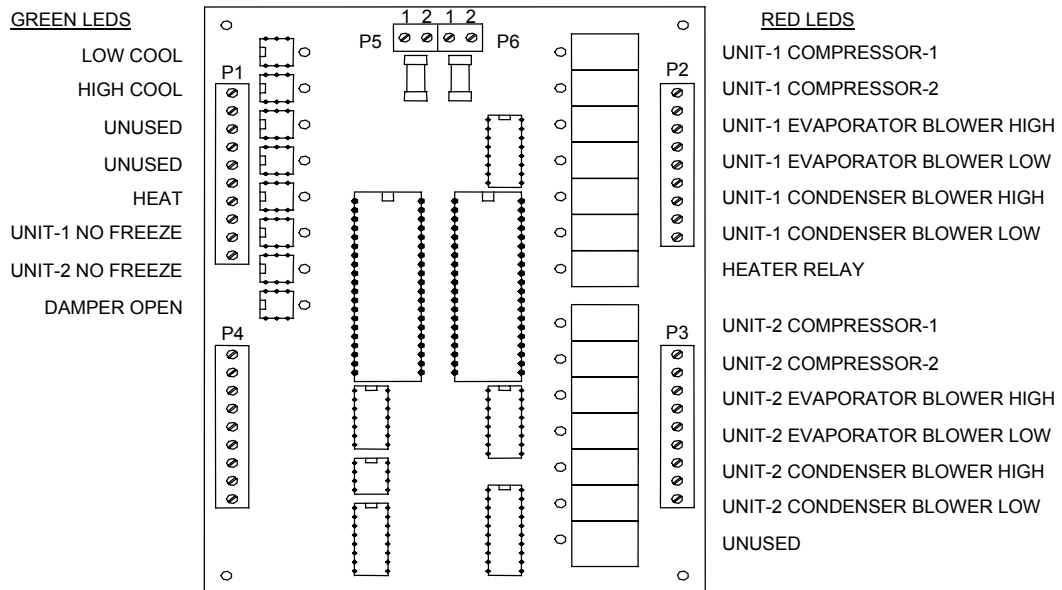

Figure 1. ECU Controller Board.

Remove the access panels of both air conditioners. Set the ECU Mode Switch in the operating area for High Cool. Monitor ECU operation by noting the LEDs as shown in Figure 1 LED configuration is also shown on the inside cover of the control box. As the air conditioners are automatically cycled through their operation (See Figure 2 for reference) note the sequence of events.

**CONTAINERIZED KITCHEN (WITH TRAILER)
UNIT MAINTENANCE PROCEDURES**

As the LED turns on during the cycle, check the voltage at the air conditioner terminal board. A voltage of 12 VDC should be noted as each LED lamp comes on. See Figure 3.

Operation	Indicator Status (Green)	Indicator Status (Red)
A/C Off	Damper Open	
Low Cool (first 2 minutes)	Damper Open Low Cool	A/C 1, Compressor 1 A/C 1, Evaporator Blower Low A/C 1, Condenser Blower Low
Low Cool (second 2 minutes)	Damper Open Low Cool	A/C 1, Compressor 1 A/C 1, Compressor 2 A/C 1, Evaporator Blower Low A/C 1, Condenser Blower Low
High Cool (first 2 minutes)	Damper Open High Cool	A/C 1, Compressor 1 A/C 1, Evaporator Blower High A/C 1, Condenser Blower High
High Cool (second 2 minutes)	Damper Open High Cool	A/C 1, Compressor 1 A/C 1, Compressor 2 A/C 1, Evaporator Blower Low A/C 1, Condenser Blower Low
High Cool (third 2 minutes)	Damper Open High Cool	A/C 1, Compressor 1 A/C 1, Compressor 2 A/C 1, Evaporator Blower Low A/C 1, Condenser Blower Low A/C 2, Compressor 1 A/C 2, Evaporator Blower High A/C 2, Condenser Blower High
High Cool (fourth 2 minutes)	Damper Open High Cool	A/C 1, Compressor 1 A/C 1, Compressor 2 A/C 1, Evaporator Blower Low A/C 1, Condenser Blower Low A/C 2, Compressor 1 A/C 2, Compressor 2 A/C 2, Evaporator Blower Low A/C 2, Condenser Blower Low
Heat	Heat	A/C 1, Evaporator Blower High A/C 1, Heater Relay

Figure 2. Air Conditioner Sequential Status.

If the diagnostic sequence is correct and the output voltages (12 VDC) are correct at each terminal board connection on the air conditioner, the ECU controller board is functioning properly, and the fault is in the air conditioner. Replace the air conditioner using the procedure in the next section.

**CONTAINERIZED KITCHEN (WITH TRAILER)
UNIT MAINTENANCE PROCEDURES**

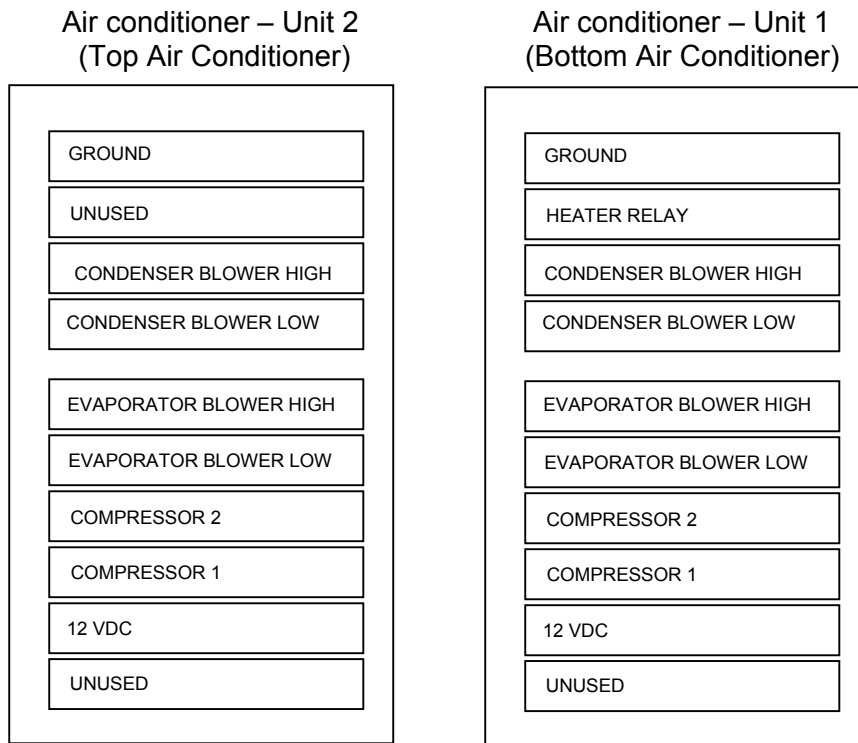

Figure 3. Air Conditioner Terminal Boards.

Generator Set:

Refer to the troubleshooting procedures in TM 9-6115-642-24 to test the generator set.

REPLACE

WARNING

Before servicing any component of the mechanical room, turn OFF and tag or lock the required circuit breaker on the Power Distribution Panel. Ensure all power is off to the component being serviced.

Power Entrance Panel: See WP 0026 00.

MBU Converter:

NOTE

There are two styles of the MBU converter (see Figure 4). Before replacing the converter, compare the replacement unit to the one that is installed. If they are both the same style, no other parts are required. If they are different styles, you must also replace the two mounting brackets and drill new screw holes. See WP 0035 00 for parts information.

**CONTAINERIZED KITCHEN (WITH TRAILER)
UNIT MAINTENANCE PROCEDURES**

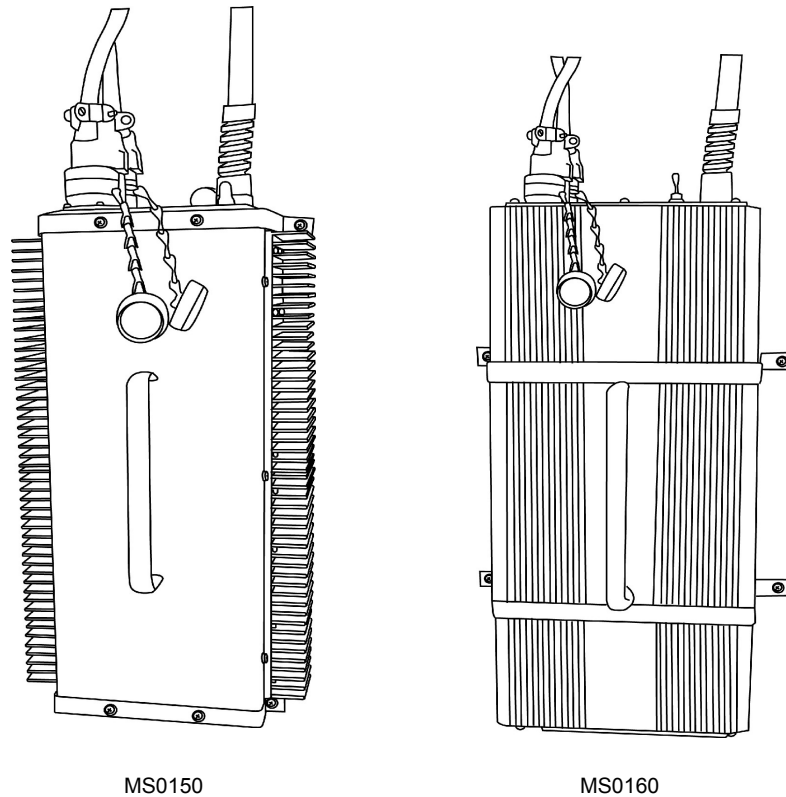

Figure 4. MBU Converter Styles.

Unplug the converter power cord from its 115 VAC receptacle. Disconnect the two 24 VDC power cables from the front of the converter. Remove the mounting screws, brackets and converter.

To install an old style (MS0150) converter, first attach the brackets to the converter using the two screws at each end of the case. If necessary, with another person holding the converter in position on the mechanical room wall, mark the locations for the mounting screws. Drill four 9/64" holes approximately 3/4" deep, being careful not to drill all the way through the wall. Attach the converter to the wall with the four mounting screws. Connect the two 24 VDC output cables and plug the power cord into the designated 115 VAC receptacle. Place the converter power switch in the ON position.

To install a new style (MS0160) converter, place the mounting brackets at each end of the handle (see Figure 4). If necessary, with another person holding the converter and brackets in position on the mechanical room wall, mark the locations for the mounting screws. Drill four 9/64" holes approximately 3/4" deep, being careful not to drill all the way through the wall. Attach the converter to the wall using the brackets and four mounting screws. Connect the two 24 VDC output cables and plug the power cord into the designated 115 VAC receptacle. Place the converter power switch in the ON position.

**CONTAINERIZED KITCHEN (WITH TRAILER)
UNIT MAINTENANCE PROCEDURES**

Exhaust Fan: Turn OFF and lock or tag Intake/Exhaust Fan circuit breakers #2 and #4 on the Power Distribution Panel. Remove and retain the four mounting bolts on the exhaust duct and remove the fan assembly. Disconnect the power cable and replace the fan using the retained hardware.

Intake Fan: Turn OFF and lock or tag Intake/Exhaust Fan circuit breakers #2 and #4 on the Power Distribution Panel. Remove the intake filter and disconnect the power cable. Remove and retain the fan mounting bolts. Install the replacement fan, replace the mounting bolts and connect the power cable. Insert the intake air filter in the duct.

Air Conditioner:

WARNING

Shut off and tag the ECU circuit breaker at the Power Distribution Panel before performing any maintenance on the air conditioners.

Removal: Shut off and tag the ECU circuit breaker at the Power Distribution Panel. Detach the fabric air duct. Remove the access panel from the side of the air conditioner. Label and disconnect the wires from the terminal block. Reattach the access panel. Disconnect the condensation drain line.

Remove the two access panels in the food preparation area. Remove the bolts connecting the air conditioner shock mounts to the support frame. A forklift is required to remove the air conditioner from the Mechanical Room. Using a forklift, lift the replacement air conditioner through the double doors of the Mechanical Room being careful that the air conditioner clears the doorway. Remove and retain the shock mounts.

Install: Install the shock mounts. Align the four mounting holes of the replacement air conditioner with the corresponding holes in the support frame. When the air conditioner is properly aligned, tighten all the mounting bolts.

Insert the power wiring through the hole in the electrical enclosure behind the electrical cover plate. Connect the power cables and attach the electrical enclosure cover plate.

Reattach the air duct and the condensation drain line. Install the two access panels in the food preparation area. Turn on power at the Power Distribution Panel and check for proper operation as described under TEST, earlier.

ECU Controller Board: The ECU Control Box (Figure) is located in the Mechanical Room next to the air conditioners. Make sure the Air Conditioner and the ECU Control circuit breakers on the Power Distribution Panel are turned OFF and tagged or locked. Open the front panel of the ECU Control Box and label the wires to terminal boards P1 through P5 as shown in Figure 1. Remove the wires and the four mounting screws. Install the replacement PC board and the mounting hardware. Reconnect all wires to the terminal boards P1 through P5. Turn on the circuit breakers and check the air conditioners for proper operation as described earlier under TEST.

CONTAINERIZED KITCHEN (WITH TRAILER) UNIT MAINTENANCE PROCEDURES

Power Supply: The ECU Control Box is mounted on the rear wall of the Mechanical Room, next to the air conditioners. Make sure the Air Conditioner and ECU Control circuit breakers on the Power Distribution Panel are turned OFF and tagged or locked. Remove the mounting screws of the power supply board to permit disassembly of the wiring on top of the board. Label and disconnect the wires from the terminal strip.

Connect the wires to the replacement board and reassemble the mounting hardware. Turn on the circuit breakers and check the air conditioners for proper operation as described earlier under TEST.

Relay: Remove the spring clip holding the relay in its socket. Unplug the relay and plug in a new one. Replace the spring clip.

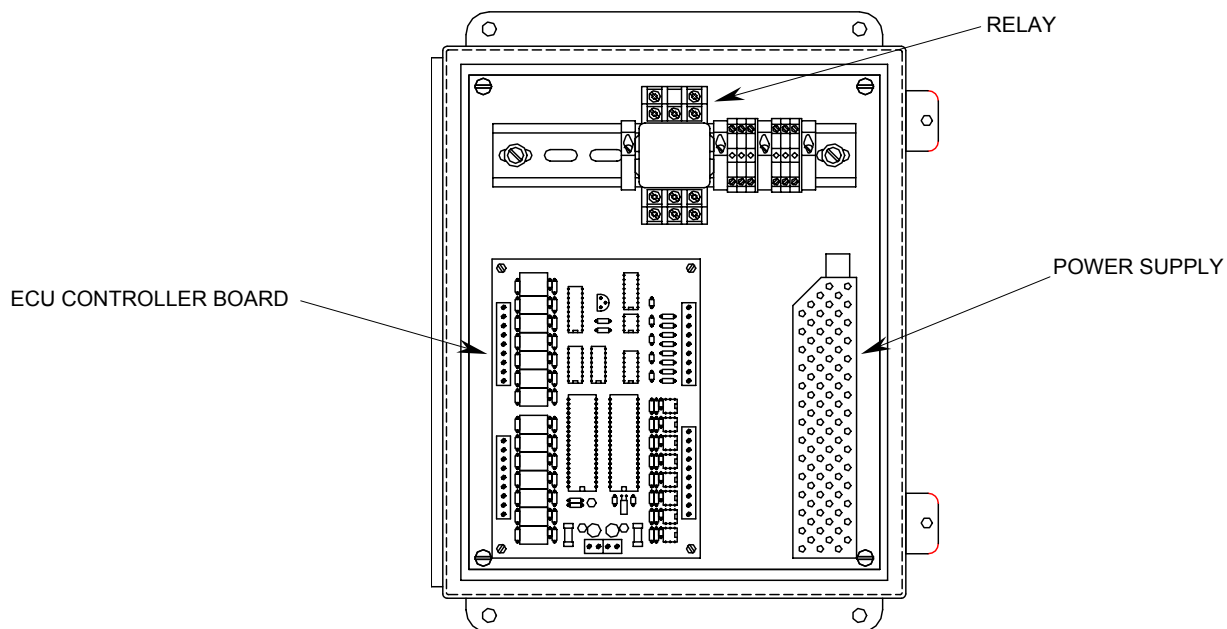

Figure 5. ECU Control Box Components.

Generator:

WARNING

Disconnect all power from the CK and all load cables from the generator before removal.

Removal: Make sure all power is disconnected from the CK. Remove the access panels that are located between the generator and the kitchen area wall. From the kitchen area disconnect the generator output terminals.

**CONTAINERIZED KITCHEN (WITH TRAILER)
UNIT MAINTENANCE PROCEDURES**

Remove the flexible exhaust pipe at the top of the generator. Remove and retain the hold down plates at the base of the generator. Leave the exhaust plenum attached the top of the generator.

A forklift is required to remove the generator from the Mechanical Room. Using a forklift of adequate capacity, remove the generator from the Mechanical Room being careful that that the generator clears the air conditioner brackets and the doorway.

Install all loose doors and hinges to the generator. Remove and retain the exhaust plenum.

Install: Attach the exhaust plenum to the top of the generator. Remove the control panel door and right side access door, leaving the hinges attached to the doors.

A forklift is required to install the generator into the Mechanical Room. Using a forklift of adequate capacity, install the generator into the Mechanical Room being careful that that the generator clears the air conditioner brackets and the doorway.

Attach the generator hold down plates using retained hardware. Connect the power cables to the output terminals of the generator set.

Install the hold-down brackets at the base of the generator set. Install the flexible exhaust pipe to the top of the generator. Place the previously removed access doors between the kitchen wall and the generator set. Close the mechanical room access doors.

END OF WORK PACKAGE

**CONTAINERIZED KITCHEN (WITH TRAILER)
UNIT MAINTENANCE PROCEDURES**

COOK CENTER**THIS SECTION COVERS:**

Inspect, Test, Replace, Repair

INITIAL SETUP:

CK set up for operation

Maintenance Level

Unit

Tools and Special Tools

Tool Kit, General Mechanic's (WP 0052 00, Table 1, Item 1)

GENERAL

This procedure contains information and instructions for inspecting, testing and repairing the CK Cook Center. Refer to WP 0036 00 for repair parts information.

INSPECT

Inspect the cook racks, griddle assembly, steam table and adapter top, cook pot cradles and exhaust hood assembly for loose hardware, broken welds and damaged rivets.

Tighten loose hardware as necessary. If frame welds are broken or loose, or a rivet is damaged, refer the repair to Direct Support maintenance.

Inspect the fuel line assembly for loose connections and damaged fuel line hoses and connectors.

Inspect the 24 VDC power cable assembly for loose connections and damaged wires or connectors.

TEST

Fuel Line: Refer to the troubleshooting procedures in the MBU manual to determine if the problem with the MBU is caused by lack of fuel. If none of the MBUs in the cook center are operational refer to the test procedures in WP 0018 00 to isolate the problem. Check the local fuel line from the main fuel line under the cook center to the MBU for signs of fuel leakage. Replace the hose assembly using the replacement procedure in the following section.

24 VDC Electrical Cable: Refer to the troubleshooting procedures in the MBU manual to determine if the problem with the MBU is caused by an absence of 24 VDC. If none of the MBUs in the cook center are operational, refer to the test procedure in WP 0018 00 to isolate the problem. Remove the power connector at the MBU and check for 24 VDC. If voltage is present, recheck the procedures in the MBU manual. If 24 VDC is not present, remove the access cover on the 24 VDC elbow under the cook center and check voltage. If voltage is

CONTAINERIZED KITCHEN (WITH TRAILER) UNIT MAINTENANCE PROCEDURES

present, repair the cable using the repair procedure in the next section. If voltage is not present refer to the test procedure in WP 0018 00.

REPLACE

Fuel Line: If the fuel line is inoperable because of a damaged connector or a cut or hole in the hose, replace the entire section of fuel line assembly by disconnecting the hose assembly and installing a replacement. See Figure 1. Remove and replace the tie-wraps as required.

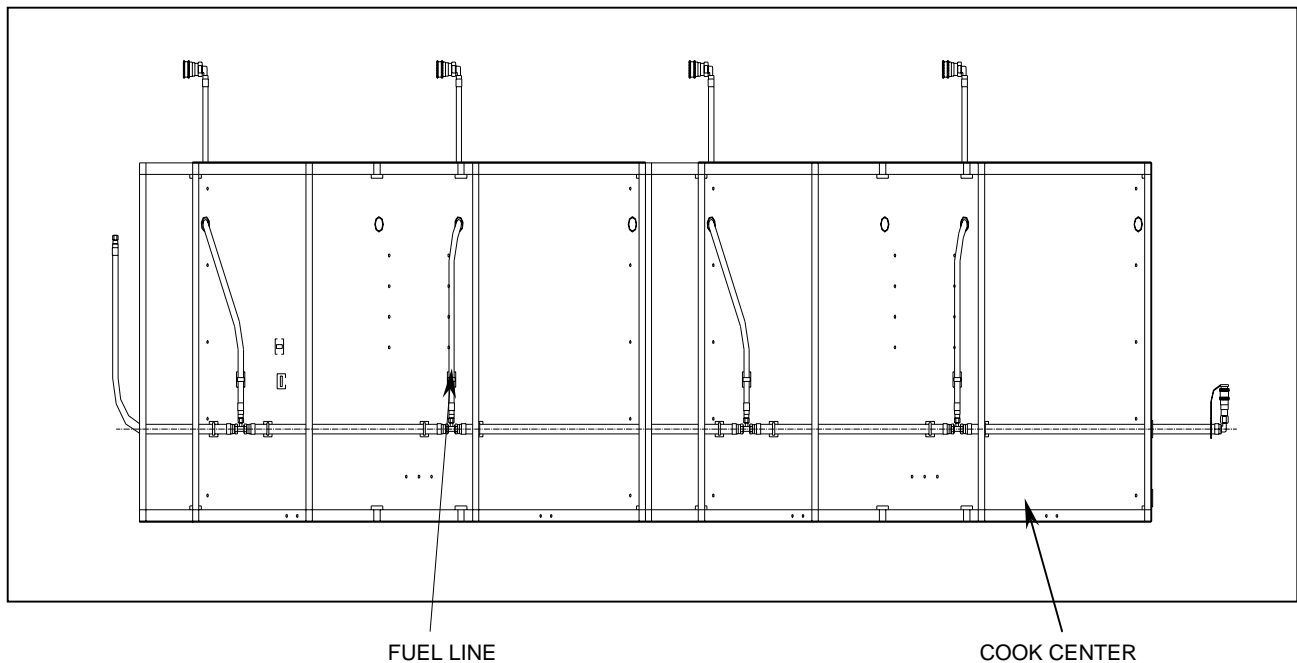

Figure 1. Cook Center Fuel Lines.

REPAIR

MBU Cable Assembly: Make sure the MBU Converter Circuit Breaker #11 on the Power Distribution Panel is turned OFF. To replace a damaged connector, disassemble the connector shell. Label and disconnect the two wires. Attach the wires to the new connector and reassemble the shell.

To repair a damaged cable, remove the cover of the junction box under the cook center, disconnect the wire nuts and pull the cable through the junction box and up through the cook center frame (see Figure 2). Cut a new cable to the desired length (WP 0045 00, Item 1) and

**CONTAINERIZED KITCHEN (WITH TRAILER)
UNIT MAINTENANCE PROCEDURES**

attach a connector to it. Slip the new cable down through the cook center frame and junction box. Attach the wire nuts and reassemble the junction box cover.

MBU: Refer to TM 10-7310-281-13&P for MBU repair procedures.

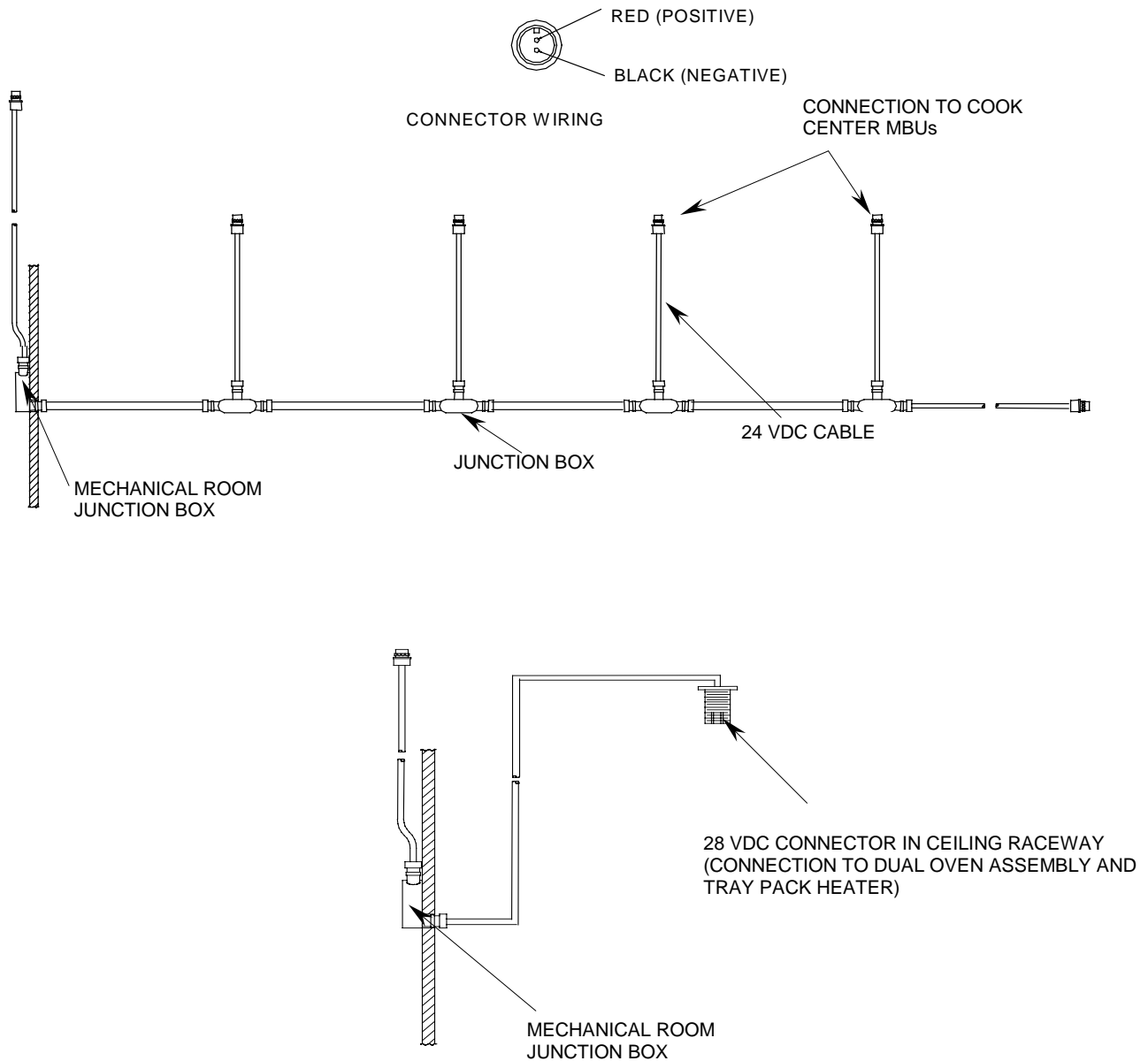

Figure 2. Cook Center 24 VDC MBU Cable Assembly.

END OF WORK PACKAGE

**CONTAINERIZED KITCHEN (WITH TRAILER)
UNIT MAINTENANCE PROCEDURES**

OVEN ASSEMBLY**THIS SECTION COVERS:**

Inspect, Test, Replace, Repair

INITIAL SETUP:

CK set up for operation
Power cables, fuel line disconnected

Maintenance Level

Unit

Tools and Special Tools

Tool Kit, General Mechanic's (WP 0052 00, Table 1, Item 1)

GENERAL

This procedure contains information and instructions for inspecting, testing and repairing the CK Oven Assembly. Refer to WP 0037 00 for repair parts information.

INSPECT

Inspect the oven base, oven and fan assembly for loose hardware, damaged rivets and broken or loose welds. Inspect base casters for smooth operation. Tighten loose hardware. Refer broken or loose frame welds or damaged rivets to Direct Support maintenance.

TEST

Fuel Line: Refer to the troubleshooting procedures in the MBU manual to determine if the problem with the MBU is caused by lack of fuel. Check the fuel line connection at the wall to the Mechanical Room. Check all hose assemblies on the back of the oven assembly for signs of fuel leakage. Replace the hose assembly using the replacement procedure in the following section.

24 VDC Electrical Cable: Refer to the troubleshooting procedures in the MBU manual to determine if the problem with the MBU is caused by an absence of 24 VDC. Remove the power connector at the MBU and check for 24 VDC. If voltage is present, recheck the procedures in the MBU manual. If 24 VDC is not present, unplug the connector from the ceiling raceway and check voltage at the receptacle. If voltage is present, repair the cable using the repair procedure in the next section. If voltage is not present refer to the test procedure in WP 0018 00.

Castors: Attempt moving the Oven Assembly with the casters unlocked. It should move freely without binding of the casters. Move the Oven Assembly in all directions to isolate the problem to a particular caster. Check for foreign material in the caster flanges.

**CONTAINERIZED KITCHEN (WITH TRAILER)
UNIT MAINTENANCE PROCEDURES**

WARNING

Three people are required to lift one side of the Oven Assembly for caster replacement .

Place a wooden block under the frame near the faulty caster and check for free rotation. Replace the caster using the replacement procedure in the following section.

Fan Assemblies: If a fan does not operate, check that the fan switch on the front of the oven is ON, the oven's 120 VAC power cable is properly connected, and the oven circuit breaker (#21) on the Power Distribution Panel is ON. Remove the access cover at the fan assembly and check for 120 VAC. If voltage is not present recheck the cable assembly and connections. Repair the cable assembly or replace the fan switch as required. If voltage is present, replace the fan assembly. Refer to the following repair procedures.

REPLACE

Caster:

WARNING

Three people are required to lift one side of the Oven Assembly for caster replacement.

Place a wooden block under the oven assembly in the vicinity of the caster as a support while the caster is being replaced. Remove and retain the four caster mounting bolts. Remove the damaged caster and bolt the new one in place using the retained hardware.

Fuel Line: If the fuel line is inoperable because of a damaged connector or a cut or hole in one of the hose sections, replace the damaged section by disconnecting it and installing a replacement (see Figure 1).

CONTAINERIZED KITCHEN (WITH TRAILER) UNIT MAINTENANCE PROCEDURES

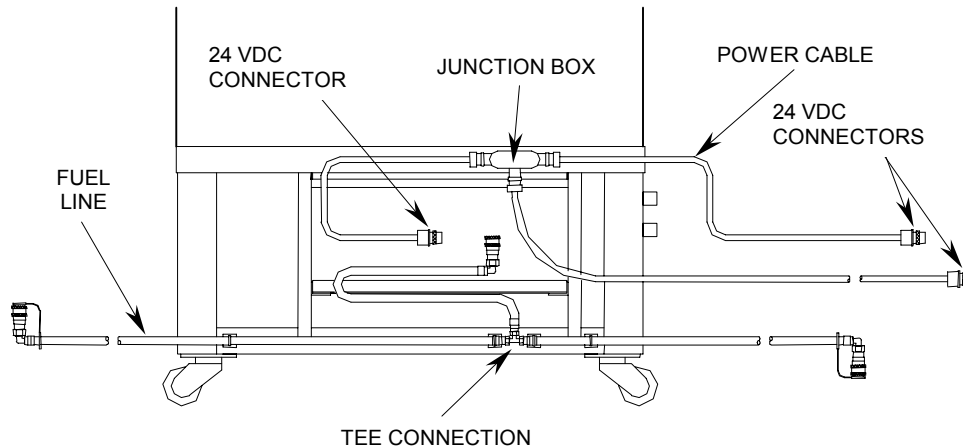

Figure 1. Oven Fuel Line and Power Cable Assemblies.

Fan Switch or Indicator Light: Remove the four attaching screws from the oven control panel and carefully pull the panel away from the front of the oven. Label and disconnect the wires to the component (switch or light) being replaced. Note that the indicator light bulb cannot be separately replaced; the complete light assembly must be replaced. Remove the defective component and install the new one. Reconnect the wires to the new component and reinstall the control panel.

REPAIR

MBU Cable Assembly: To replace a section of the 24 VDC cable, remove the junction box cover (see Figure 1). Label and disconnect the wires and pull the cable through the junction box. Cut a new cable to the desired length (WP 0045 00 Item 1) and attach a connector to it. Slip the new cable into the junction box, connect the wires and replace the junction box cover.

24 VDC Connector: To replace a damaged connector, disassemble the connector shell. Label and disconnect the two wires. Attach the wires to the new connector and assemble it.

MBU: Refer to TM 10-7310-281-13&P for MBU repair procedures.

END OF WORK PACKAGE

**CONTAINERIZED KITCHEN (WITH TRAILER)
UNIT MAINTENANCE PROCEDURES**

MOBILE WARMING CABINET**THIS SECTION COVERS:**

Inspect, Test, Replace

INITIAL SETUP:

CK set up for operation
Warming cabinet operational

Maintenance Level

Unit

Tools and Special Tools

Tool Kit, General Mechanic's (WP 0052 00, Table 1, Item 1)

GENERAL

This procedure contains information and instructions for inspecting and repairing the Mobile Warming Cabinet. Refer to WP 0038 00 for repair parts information.

WARNING

Unplug the power cord before performing any maintenance on the warming cabinet.

INSPECT

Inspect the door gaskets and door seals for signs of wear or damage.

TEST

Cabinet: If the warming oven is not heating at all, check that the warming oven power cord is connected properly, the master switch is On and the circuit breaker at the Power Distribution Panel is On. Disconnect the power cord and remove the Module using the procedure in the following section. Temporarily connect the power cord and check for 115 VAC at the power switch. If voltage is present on both sides of the switch the module requires replacement. Replace the power switch if required.

If the temperature in the warming oven is erratic or cannot be controlled, check the voltage at the thermostat. Rotate the thermostat control while checking voltage. A smooth change in voltage over the range of the thermostat should be noted. Replace the thermostat if necessary.

If the warming oven is operating normally but the indicator lamps are not lit, check voltage at the terminal block and replace the indicator lights if necessary.

If insufficient warming of the Cabinet is noted, visually check the door seals and gasket for warpage or deteriorated condition of the seals. If the warming oven is on, it may be possible to detect a deteriorated gasket by noting loss of internal heat to the outside.

**CONTAINERIZED KITCHEN (WITH TRAILER)
UNIT MAINTENANCE PROCEDURES**

Casters: Attempt moving the Mobile Warming Cabinet with the casters unlocked. It should move freely without binding of the casters. Move the cabinet in all directions to isolate the problem to a particular caster. Check for foreign material in the caster flanges. Refer to the procedure in the following section to replace a caster.

REPLACE**Cabinet Parts**

Caster: The front casters are equipped with a wheel brake. Rear casters do not have a brake. If necessary, a caster with a brake can be installed as a rear caster leaving the brake unlocked.

WARNING

Two people are required to lay the Mobile Warming Cabinet on its back.

To replace a front or rear caster, lay the cabinet on its back, remove the module, and remove caster mounting hardware and caster. Replace caster using existing hardware. Replace the module.

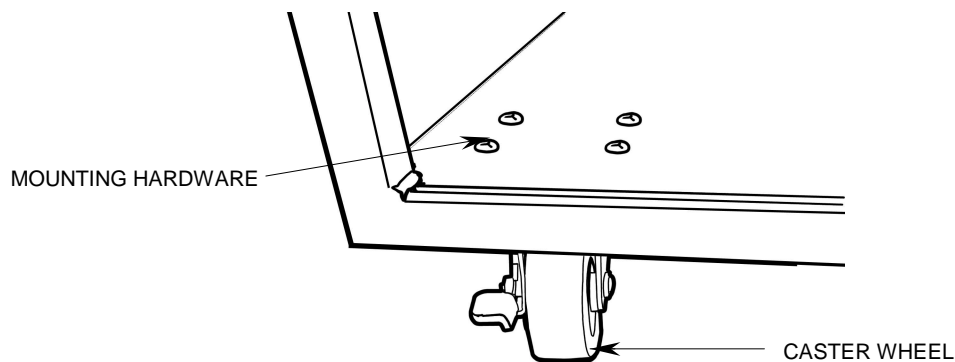

Figure 1. Swivel Caster Replacement.

Door Gasket: Refer to Figure 2. Starting at a corner, remove the old gasket from the door by pulling it out of the groove in the door frame. To install the replacement gasket, press the arrow-shaped edge of the new gasket into the groove. It may take up to eight hours depending on the ambient temperature for the gasket to seat properly.

Door Seal: Refer to Figure 2. Remove and retain the five door seal mounting screws and the door seal retaining strip. Install the new door seal using retained hardware.

CONTAINERIZED KITCHEN (WITH TRAILER) UNIT MAINTENANCE PROCEDURES

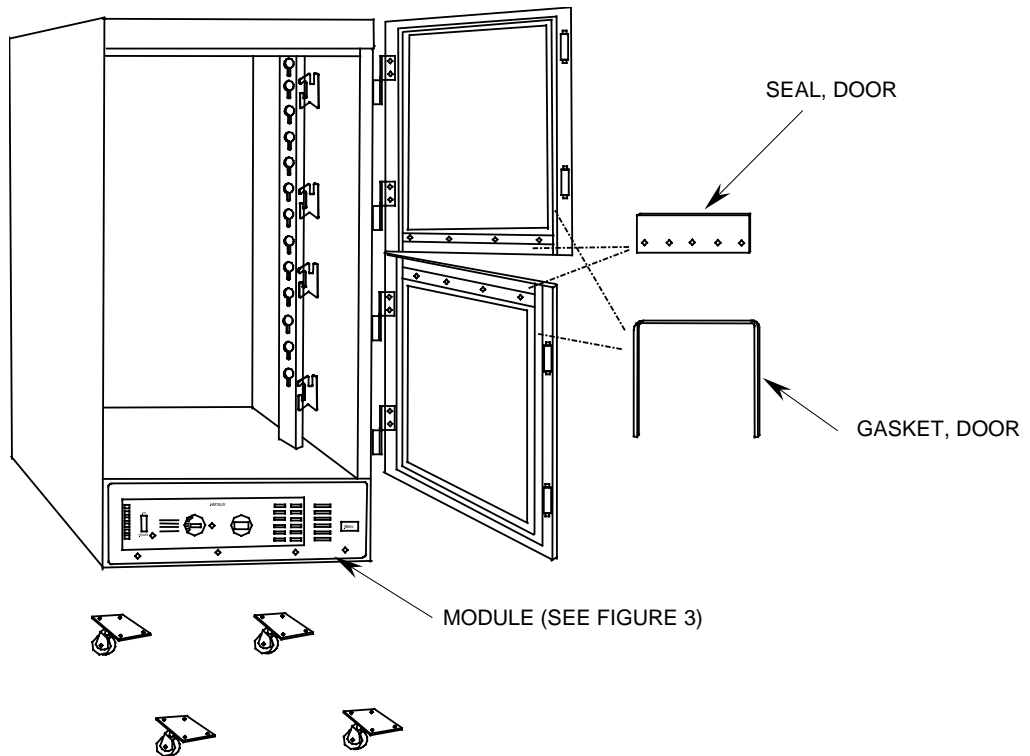

Figure 2. Mobile Warming Cabinet Maintenance.

Module

The module (Figure 3) is removed from the cabinet using the following procedure:

Make sure the power cord is unplugged and that the module has cooled to a temperature safe for handling.

Open the bottom door. Remove the module by lifting the front enough to clear the detent, then pull the module from the cabinet. The power cord should slip through the clearance hole in the back of the cabinet.

Unfasten the electrical cover by removing the screws along the front bottom of the module and the top panel. Remove the water pan from the top cover. Open the module by lifting the unit from the chassis. Turn the unit over for access to the components.

Power Cord: Label and disconnect the power cord wires. Using pliers, squeeze the strain relief from inside and push out.

Slip the replacement power cord through the strain relief and then through the mounting hole. Connect the black and white wires and the green ground wire. Snap the strain relief in place.

**CONTAINERIZED KITCHEN (WITH TRAILER)
UNIT MAINTENANCE PROCEDURES**

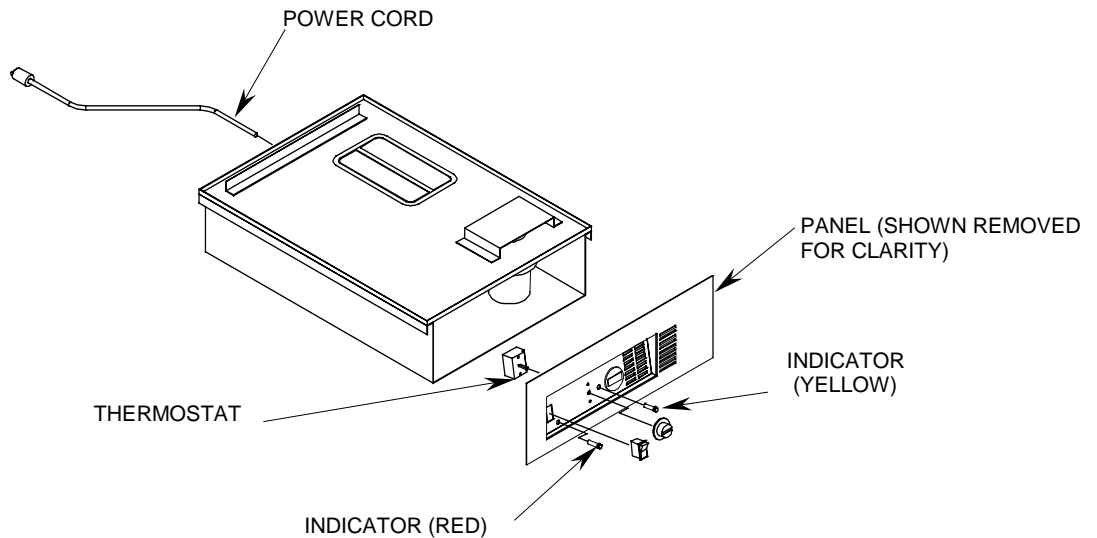

Figure 3. Cabinet Module.

Thermostat: Pull the control knob from the thermostat to expose the two mounting screws. Remove and retain the mounting screws and pull the thermostat from the control panel to gain access to the ring terminal connections. Replace the thermostat and retained hardware.

Indicator Light (yellow): Using a small screwdriver, pry loose the clip retaining the indicator light to be replaced. Trace the two wires from the fan to the terminal block, label the wires and disconnect them. Draw the indicator light and wire through the control panel.

Install the new indicator light. Affix crimp-on spade terminals to each wire lead. Feed the new light through the hole in the panel and press on the retaining clip. Connect the leads to the terminal block.

Power Indicator Light (red): Trace the two wires running from the light to the terminal block, label the wires and disconnect them. Pry loose the clip retaining the light. Depress the tabs on the light body and draw it through the hole in the control panel. Replace the light. Affix crimp-on spade terminals to each wire lead. Connect the wires to the terminal block.

Power Switch: Label and disconnect the wires connected to the switch. Depress the tabs on the switch and push the switch back through the control panel. Snap the new switch into place and reconnect the wires.

END OF WORK PACKAGE

**CONTAINERIZED KITCHEN (WITH TRAILER)
UNIT MAINTENANCE PROCEDURES**

REFRIGERATOR**THIS SECTION COVERS:**

Inspect, Test, Replace

INITIAL SETUP:

CK set up for operation
Refrigerator power cord unplugged

Maintenance Level

Unit

Tools and Special Tools

Tool Kit, General Mechanic's (WP 0052 00, Table 1, Item 1)

GENERAL

This procedure contains information and instructions for inspecting and repairing the refrigerator. Refer to WP 0039 00 for repair parts information.

WARNING

Unplug the power cord before performing any maintenance on the refrigerator.

INSPECT

Inspect the door gasket for tears, cuts or deterioration that would prevent an adequate seal. Inspect the shelf brackets for damage. Inspect the interior and exterior for dirt and foreign materials that could cause a malfunction or restrict air flow. Inspect the swivel casters for smooth operation. Inspect the power cord and plug for damage.

TEST

Refrigeration Unit: If the refrigerator is not cooling at all, check that the circuit breaker on the Power Distribution Panel is ON and that the refrigerator power cord is properly connected. Unplug the refrigerator and remove the screws from the access cover at the bottom rear of the refrigerator. Unplug the connector at the bottom of the refrigerator and temporarily connect the power cord to the 115 VAC outlet. If 115 VAC is present at the refrigerator end of the cord, the refrigerator needs to be replaced. If 115 VAC is not present, recheck all power connections and the power cord. Replace the power cord following the procedure in the next section.

If the refrigerator is not cooling sufficiently as indicated by the thermometer, turn the temperature controller clockwise and determine if the compressor turns on and the temperature gradually decreases. If it does not the temperature controller needs to be replaced. Follow the replacement procedures in the next section. If the temperature controller is operating normally, check the door gasket for leaks. This test can be performed by detecting cold air around the perimeter of the door and by visually inspecting the entire gasket for hardness, cuts and a deteriorated condition.

**CONTAINERIZED KITCHEN (WITH TRAILER)
UNIT MAINTENANCE PROCEDURES**

Casters: Attempt moving the refrigerator with the casters unlocked. It should move freely without binding of the casters. Move the refrigerator in all directions to isolate the problem to a particular caster. Check for foreign material in the caster flanges. Refer to the procedure in the following section to replace a caster.

REPLACE

Power Cord: Make sure the power cord is unplugged from the electrical outlet. Remove the screws from the access cover at the bottom rear of the refrigerator. Unplug the connector and remove the green ground wire. Install the replacement power cord and securely connect the green ground wire.

Temperature Controller: See Figure 1. Remove the five machine screws from the fan/controller panel at the inside top of the refrigerator. Loosen the panel from the side molding strips being careful not to damage the trim or the wiring behind the panel. Disconnect the temperature-controller connector. Remove the mounting hardware of the temperature controller. Install the replacement controller using existing hardware. Reinstall the fan/controller panel and slide the side molding strips onto the edges of the panel.

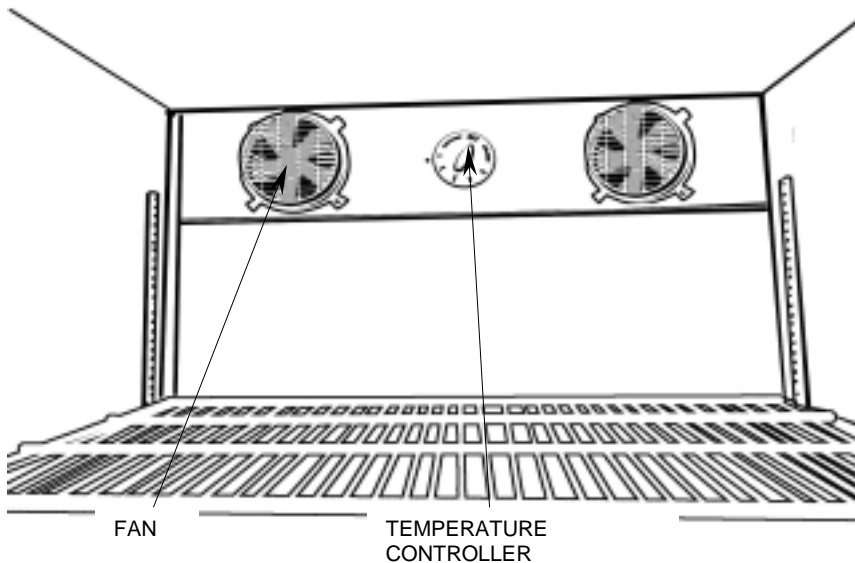

Figure 1. Refrigerator Interior.

Door Gasket: Remove the screws from underneath the gasket material. Align the new gasket around the door so that the screw holes are aligned. Replace all hardware.

**CONTAINERIZED KITCHEN (WITH TRAILER)
UNIT MAINTENANCE PROCEDURES**

Caster: See Figure 2. To replace a front caster, unsnap and remove the grille at the bottom of the refrigerator, then remove the drip pan. To replace a rear caster, remove the access cover at the bottom rear of the unit.

WARNING

Two people are required to lay the refrigerator on its back.

Place the refrigerator on its back on the kitchen floor. Check the faulty caster for free rotation. Remove the hex nut and the caster. Install the new caster and hex nut. Place the refrigerator in its upright position. As applicable, reinstall the drip pan, grille, and access cover. If possible, allow the refrigerator to remain in its upright position for an hour before applying power.

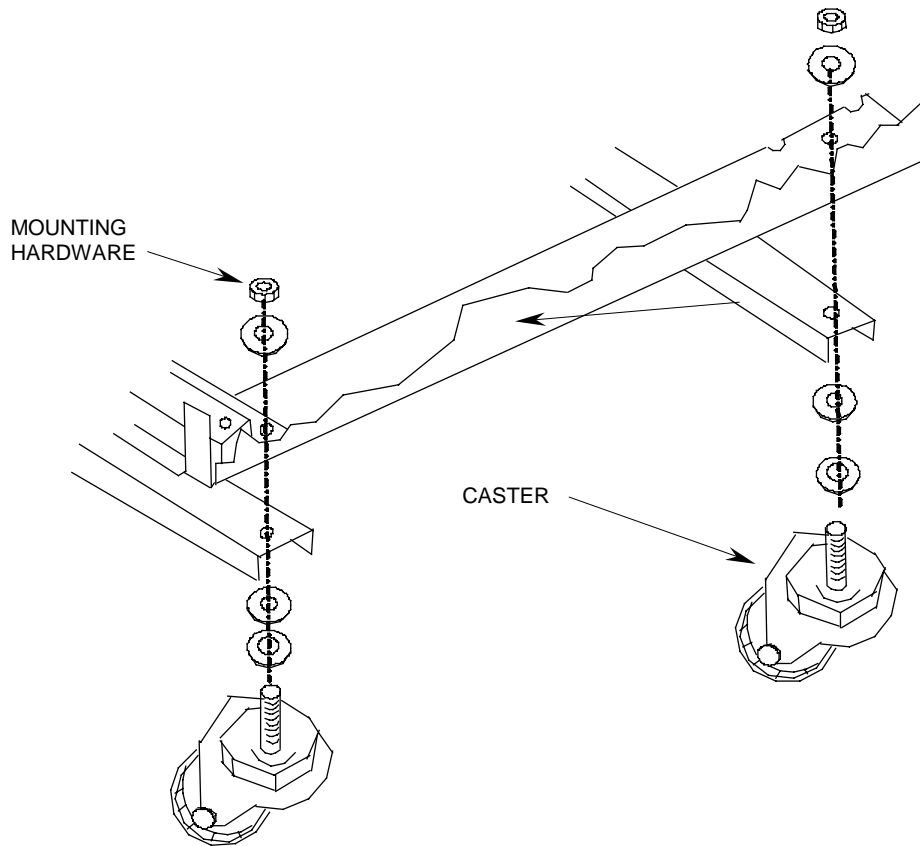

Figure 2. Swivel Caster Replacement.

END OF WORK PACKAGE

**CONTAINERIZED KITCHEN (WITH TRAILER)
UNIT MAINTENANCE PROCEDURES**

TRAY PACK HEATER**THIS SECTION COVERS:**

Inspect, Test, Replace

INITIAL SETUP:

CK set up for operation

Heater fan assembly unplugged

Maintenance Level

Unit

Tools and Special Tools

Tool Kit, General Mechanic's (WP 0052 00, Table 1, Item 1)

GENERAL

This procedure contains information and instructions for inspecting and repairing the Tray Pack Heater. Refer to WP 0040 00 for repair parts information.

INSPECT

Inspect the Tray Pack Heater and the heater fan assembly for loose hardware and damaged rivets. Inspect the fan assembly power cable for damage.

TEST

Casters: Disconnect the fuel line and power cord. Attempt moving the Tray Pack Heater with the casters unlocked. It should move freely without binding of the casters. Move the cabinet in all directions to isolate the problem to a particular caster. Check for foreign material in the caster flanges. Refer to the procedure in the following section to replace a caster.

Drain Valve: Check for external leakage of the drain and that it is not clogged with foreign material. Replace the drain valve if necessary following the procedure in the next section.

Heater Fan: If the fan motor shaft is not rotating, check that the power switch on the appliance control box is ON and the power cable properly connected. Check the circuit breakers at the Appliance Control Box and the Power Distribution Panel. Remove the access cover at the fan assembly and check for 115 VAC. If voltage is not present recheck the cable assembly and connections. Replace the cable assembly if required. Check the heater fan receptacle by plugging the fan cable into a different receptacle. If voltage is present, replace the fan assembly. Refer to the following repair procedures.

**CONTAINERIZED KITCHEN (WITH TRAILER)
UNIT MAINTENANCE PROCEDURES**

REPLACE

Caster: See Figure 1. Drain the Tray Pack Heater. Support the Tray Pack Heater with a wooden block in the vicinity of the caster while the caster is being replaced. Remove the four bolts and the damaged caster. Install the new caster and mounting hardware.

Drain Valve: See Figure 1. Drain any liquid from the Tray Pack Heater. Remove the drain valve and replace using pipe joint compound (WP 0051 00, Table 1, Item 3) as required.

Heater Fan: Disconnect the fan assembly power cord. Remove and retain the fan assembly mounting hardware. Install the replacement fan using the retained hardware.

Lifting Handles: Refer any damage to the lifting handles to Direct Support maintenance.

MBU: Refer to TM 10-7310-282-13&P for MBU repair procedures.

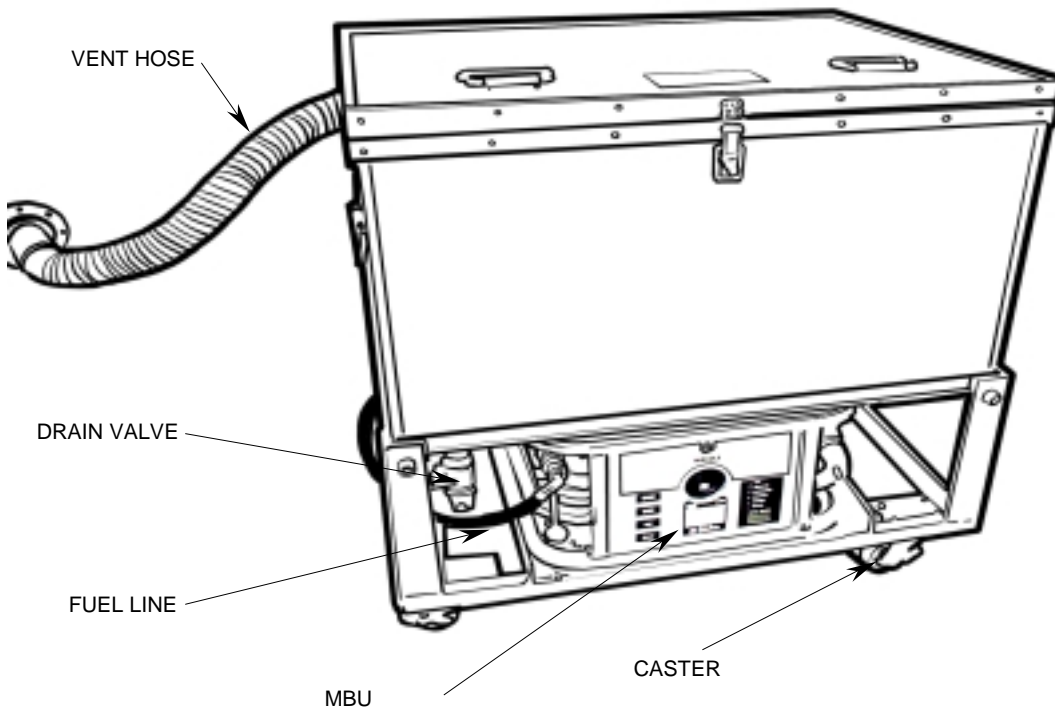

Figure 1. Tray Pack Heater Components.

END OF WORK PACKAGE

**CONTAINERIZED KITCHEN (WITH TRAILER)
UNIT MAINTENANCE PROCEDURES**

HAND SINK ASSEMBLY**THIS SECTION COVERS:**

Inspect, Test, Replace

INITIAL SETUP:

CK set up for operations

Water pump and water heater connected to the Appliance Control Box

Water supply hose connected

Drain hose connected

Maintenance Level

Unit

Tools and Special Tools

Tool Kit, General Mechanic's (WP 0052 00, Table 1, Item 1)

GENERAL

This procedure contains information and instructions for inspecting and repairing the Hand Sink Assembly. Refer to WP 0041 00 for repair parts information.

WARNING

Disconnect the pump and water heater power cables from the Appliance Control Box before making any repairs to the sink assembly.

WARNING

The water in the hot water tank may be hot. Allow the water to cool before opening the drain valve.

INSPECT

Inspect water connections for leaks at the pump head, in the area around the water heater, and the faucet above and below the sink. Inspect electrical connectors and cords for damage. Inspect the water supply hoses and interior drain hose for damage, missing or damaged washers or gaskets.

**CONTAINERIZED KITCHEN (WITH TRAILER)
UNIT MAINTENANCE PROCEDURES**

TEST

Pump Assembly: Run faucet water into the sink. The pump should run periodically. Check the pump assembly by temporarily connecting the pump assembly power cord to the Appliance Control Box and check for 115 VAC at the pressure switch. Disconnect the power cord from the appliance control box. Replace the pump if necessary.

Water Heater: The water heater can be tested by removing the access cover at the side of the tank. Temporarily connect the water heater power cord to the appliance control box and check for 115 VAC between terminals 1 and 3 (refer to wiring diagram on side of water heater). Depress the reset button and recheck voltages. If the 115 VAC is present the water heater should be replaced following the procedure in the next section. If the 115 VAC is not present, check the power cord and refer to WP 0018 to check power distribution. Disconnect the power cord from the appliance control box.

Casters: Disconnect the power cords from the Appliance Control Box. Attempt moving the sink assembly with the casters unlocked. It should move freely without binding of the casters. Move the sink in all directions to isolate the problem to a particular caster. Check for foreign material in the caster flanges. Refer to the procedure in the following section to replace a caster.

REPLACE

Caster: The sink assembly contains locking casters in the front of the assembly and non-locking casters in the back. Locking casters may be used as replacements for non-locking casters with the caster left in the unlocked position. See Figure 1. To replace a caster (front or back) remove the four screws from the mounting plate and the damaged caster. Replace the caster and reinstall the four screws.

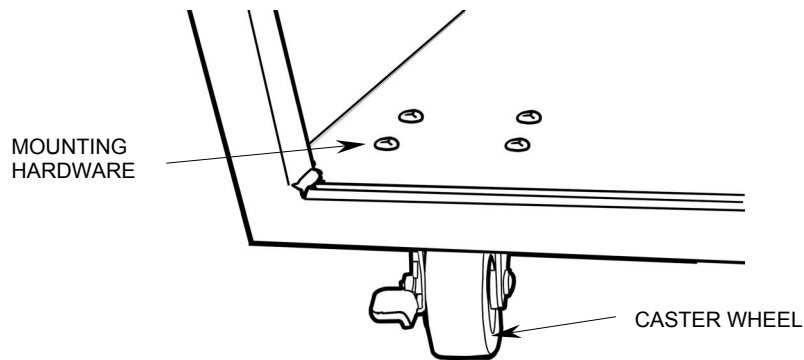

Figure 1. Swivel Caster Replacement.

CONTAINERIZED KITCHEN (WITH TRAILER) UNIT MAINTENANCE PROCEDURES

Sink Assembly Top Removal: To provide access for inspection and maintenance of the water heater and the pump assembly, the top of the sink assembly can be removed.

NOTE

On some hand sink assemblies, the top is riveted in place and cannot be removed. The steps below do not apply to assemblies with a riveted top.

To remove the sink assembly top, tag and disconnect the hot and cold water lines from the faucet. Then remove the 14 screws that attach the top to the sink cabinet. Using two people, carefully lift the top off the cabinet and set it aside, being careful not to damage the soap dispenser or the drain connection on the bottom of the sink.

To reinstall the top, use two people to place it on the sink cabinet, making sure the soap dispenser is toward the back (open) side of the cabinet. Reinstall the 14 screws. Reconnect the hot and cold water lines to the faucet.

Water Heater: See Figure 2. To replace the water heater, disconnect the power cord at the bottom of the tank. Allow the water in the tank to cool, open the drain valve and drain the water into an empty bucket or drain system. Remove the locking nuts from the mounting bracket at the side of the sink assembly. Remove the supporting bracket under the water heater and lift the water heater out of the sink assembly.

Remove and discard the curved bracket attached to the side of the replacement water heater. Remove this same bracket from the side of the bad water heater and install it onto the replacement water heater.

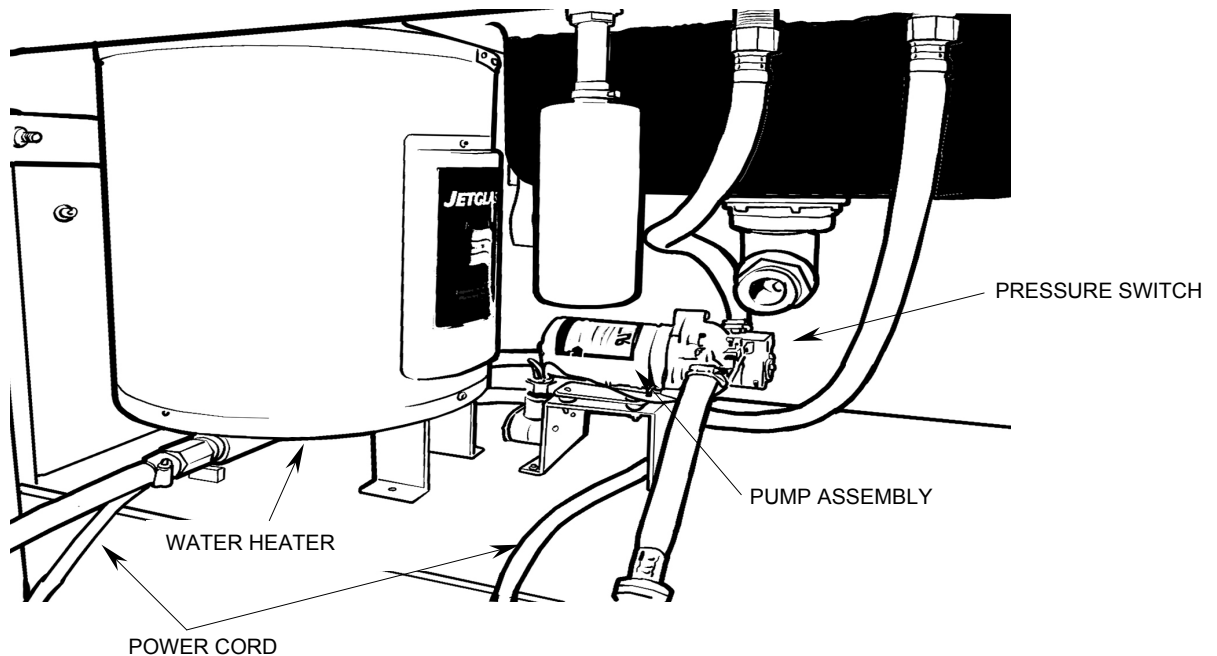

Figure 2. Sink Assembly Maintenance.

**CONTAINERIZED KITCHEN (WITH TRAILER)
UNIT MAINTENANCE PROCEDURES**

Install the replacement water heater, reinstall the mounting hardware, hoses, and the electrical connector.

Pump Assembly: See Figure 2. To replace the pump assembly, label the wires and disconnect the power cord at the junction box on the pump assembly mounting bracket. Remove the four screws from the pump assembly mounting plate. Retain the rubber mounting spacers.

Install the replacement pump, the four mounting spacers and screws on to the mounting plate. Reconnect the power cord to the junction box.

Faucet: To replace the faucet, disconnect the hot and cold water supply lines under the sink. Remove the nuts and washers from the faucet pipes and remove the faucet. Insert a replacement faucet and reassemble the washers and nuts.

Hoses: If a water supply hose or the interior drain hose is damaged, replace it. If a washer or gasket is damaged, remove it with a small screwdriver or needle nose pliers and replace it with a new one.

END OF WORK PACKAGE

**CONTAINERIZED KITCHEN (WITH TRAILER)
UNIT MAINTENANCE PROCEDURES**

MOBILE STORAGE CABINETS**THIS SECTION COVERS:**

Inspect, Test, Repair

INITIAL SETUP:

CK set up for operation

Maintenance Level

Unit

Tools and Special Tools

Tool Kit, General Mechanic's (WP 0052 00, Table 1, Item 1)

GENERAL

This procedure contains information and instructions for inspecting and making repairs to the Mobile Storage Cabinets. Refer to WP 0042 00 for repair parts information.

INSPECT

Inspect Mobile Storage Cabinets for broken welds, damaged rivets or damaged casters. Refer any sheet metal or weld repairs to Direct Support maintenance.

TEST

Castors: Attempt moving the storage cabinet with the casters unlocked. It should move freely without binding of the casters. Move the cabinet in all directions to isolate the problem to a particular caster. Check for foreign material in the caster flanges. Refer to the procedure in the following section to replace a caster.

REPLACE

Caster: Lay the cabinet on its back. Remove and retain the caster mounting hardware. Install the new caster using the retained hardware.

END OF WORK PACKAGE

**CONTAINERIZED KITCHEN (WITH TRAILER)
UNIT MAINTENANCE PROCEDURES**

ELECTRICAL SYSTEM**THIS SECTION COVERS**

Inspect, Test, Replace

INITIAL SETUP

CK set up for operation
External power disconnected, generator shut down

Maintenance Level

Unit

Tools and Special Tools

Tool Kit, General Mechanic's (WP 0052 00, Table 1, Item 1)

GENERAL

This procedure contains information and instructions for inspecting, testing and making repairs to the CK electrical system. Refer to WP 0044 00 for repair parts information.

WARNING

Disconnect the external power cable and ensure generator power is OFF before making repairs to the Power Entrance Panel, Power Distribution Panel, or Main Control Panel.

INSPECT

Inspect the condition of each circuit breaker, ground, neutral, and 220V/115V connection at the Power Entrance Panel, Power Distribution Panel, Main Control Panel and Appliance Control Box. Inspect lighting fixtures for loose or damaged hardware, frayed power cords, and damaged connectors.

TEST

Power Entrance Panel: Using a multimeter, check the power voltage on both sides of the applicable circuit breaker the OFF position and ON position. With External Power ON at the Main Control Panel check the voltage at contactor CR2. If generator power is being used check voltage at contactor CR1. Follow the circuit diagrams in WP 0054 00 to check connections. Replace faulty component using the procedure in the following section.

Appliance Control Box: Using a multimeter, check the voltage on both sides of the applicable circuit breaker and switch assemblies in the OFF position and ON position. Follow the circuit diagrams in WP 0054 00 to check connections. Replace faulty component using the procedure in the following section.

CONTAINERIZED KITCHEN (WITH TRAILER) UNIT MAINTENANCE PROCEDURES

Power Distribution Panel: Using a multimeter, check the voltage on both sides of the applicable circuit breaker in the OFF position and ON position. Follow the circuit diagrams in WP 0054 00 to check connections.

Main Control Panel: Using a multimeter, check the voltage on both sides of the applicable switch assembly in the OFF position and ON position. Check voltage at the applicable lamp assembly. Follow the circuit diagrams in WP 0054 00 to check connections. Replace faulty component using the procedure in the following section.

Lighting Fixture: If the fluorescent lamps don't light upon replacement, remove the access plate on the fixture. Refer to the ballast wiring diagram in on the ballast to check output voltage. Replace the ballast if required using the procedure in the next section.

With the Interior Light switch ON and the Emergency Light switch OFF, depress the Test switch on the fluorescent light fixture above the personnel entrance door. The lamps on the fixture should be off. Turn the Emergency Light switch ON and depress the Test switch. The lamps should be on. If the battery charger in the light fixture fails to charge with the Emergency Light switch ON it requires replacement using the procedure in the following section.

REPLACE

Power Entrance Panel

Power Connector: Make sure all power is turned off at the Main Control Panel. Referring to Figure 1, disconnect the source power plug at the Power Entrance Panel and attach plug cover. Label and disconnect power leads from the external power contactor. Remove and retain connector mounting hardware and remove the connector. Install the replacement connector and retained hardware. Reconnect power leads at the contactor.

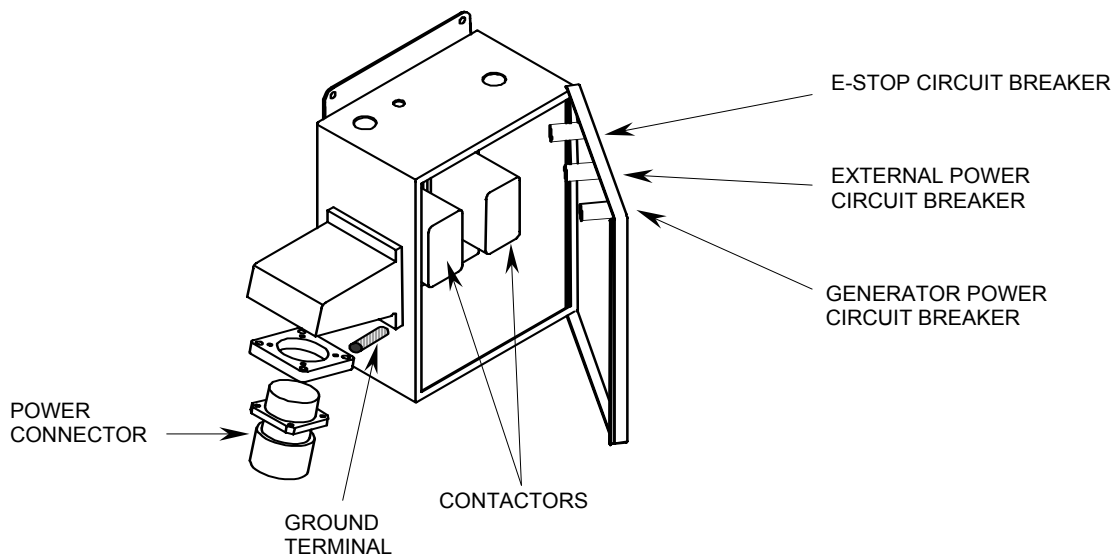

Figure 1. Power Entrance Panel.

Ground Terminal: Make sure all power is turned off at the Main Control Panel. Referring to Figure 1, disconnect the source power plug at the Power Entrance Panel and attach plug cover. Remove the mounting hardware from inside the Power Entrance Panel. Disconnect the green

**CONTAINERIZED KITCHEN (WITH TRAILER)
UNIT MAINTENANCE PROCEDURES**

ground wires and remove the ground terminal from the outside of the panel box. Install the new ground terminal using existing hardware. Reconnect green wires.

Contactors: Make sure all power is turned off at the Main Control Panel. Referring to Figure 1, disconnect the source power plug at the Power Entrance Panel and attach plug cover. Label and disconnect spade terminals. Remove and retain the contactor mounting hardware. Install the replacement contactor using retained hardware.

If necessary, replace the circuit breaker by disconnecting the neutral and high voltage wires and installing a replacement.

Reconnect the wires and reinstall the panel cover.

Appliance Control Box

Switch Replacement: Unplug the control box power cord from the ceiling raceway. Referring to Figure 2, remove the mounting nut on the front of the panel. Remove terminal lugs from the switch and remove the switch from the back of the panel. Replace the switch, reinstall hardware and connect terminal lugs.

Circuit Breaker Replacement: Unplug the control box power cord from the ceiling raceway. Referring to Figure 2, depress the locking springs on the sides of the circuit breaker assembly and slide the circuit breaker through the front of the panel. Replace the circuit breaker and reconnect the terminal lugs.

Connector Replacement: Unplug the control box power cord from the ceiling raceway. Referring to Figure 2, label and disconnect the wires at the junction strip. Remove the mounting nut and the connector. Install the replacement connector using existing hardware.

Power Distribution Panel

Circuit Breaker Replacement: Make sure the external power source is disconnected and the generator is shut down. Remove the circuit panel cover. See Figure 3 for circuit breaker locations. Disconnect the neutral and high voltage wires and install a new circuit breaker. Reconnect the wires and reinstall the panel cover.

**CONTAINERIZED KITCHEN (WITH TRAILER)
UNIT MAINTENANCE PROCEDURES**

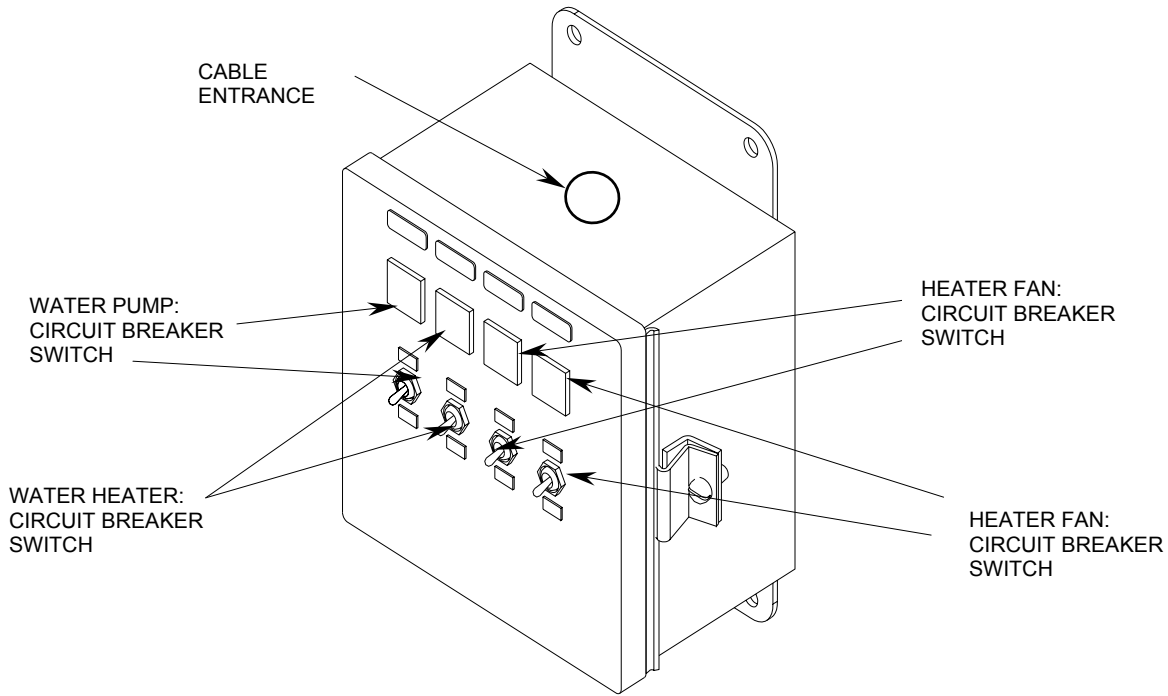

Figure 2. Appliance Control Box.

1	Input Power	2	Intake/Exhaust Fan
3	Input Power	4	Intake/Exhaust Fan
5	Input Power	6	Heater
7	Refrigerator 1	8	Heater
9	Refrigerator 2	10	Heater
11	MBU Converter	12	Convenience Outlets
13	ECU	14	Mechanical Room Outlet
15	ECU	16	Warming Cabinet
17	ECU	18	ECU Control Box
19	Lights	20	Blank/not used
21	Oven Assembly	22	Blank/not used
23	Blank/not used	24	Appliance Control Box

Figure 3. Circuit Breaker Layout of the Power Distribution Panel.

**CONTAINERIZED KITCHEN (WITH TRAILER)
UNIT MAINTENANCE PROCEDURES**

Main Control Panel:

Switch/Lamp Replacement: Make sure the external power source is disconnected and the generator is shut down. Referring to Figure 4, label and remove the spade lugs from the switch/lamp to be replaced. Remove the mounting hardware from the front of the panel and remove the switch/lamp assembly. Install the replacement switch/lamp assembly, replace hardware and reconnect spade lug terminals.

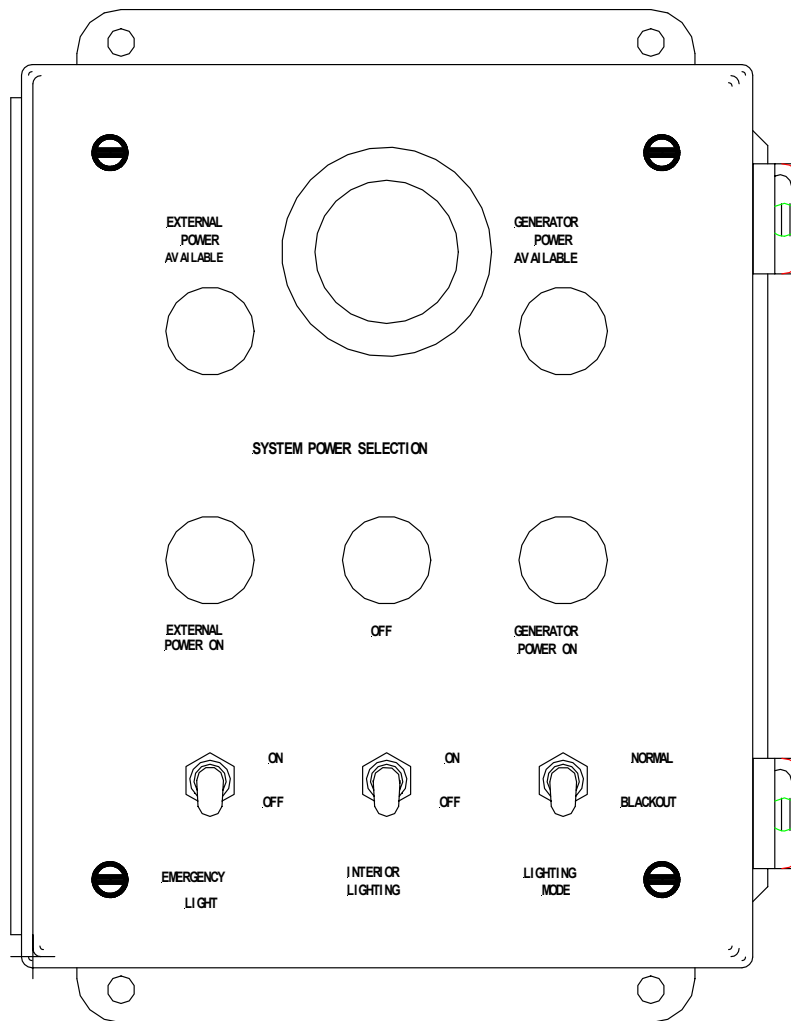

Figure 4. Main Control Panel.

**CONTAINERIZED KITCHEN (WITH TRAILER)
UNIT MAINTENANCE PROCEDURES**

Lighting Fixtures

Permanently Mounted Fixture Ballast Replacement: Turn off lighting system circuit breaker #19 on the Power Distribution Panel. Referring to Figure 5, remove the connectors at the fixture, tag the wires connected to the ballast and disconnect the wires. Remove the four machine screws from the ballast plate and remove the ballast.

Install the replacement ballast, connect wires and wire nuts. Attach access plate and tighten machine screw. Reconnect power line connectors.

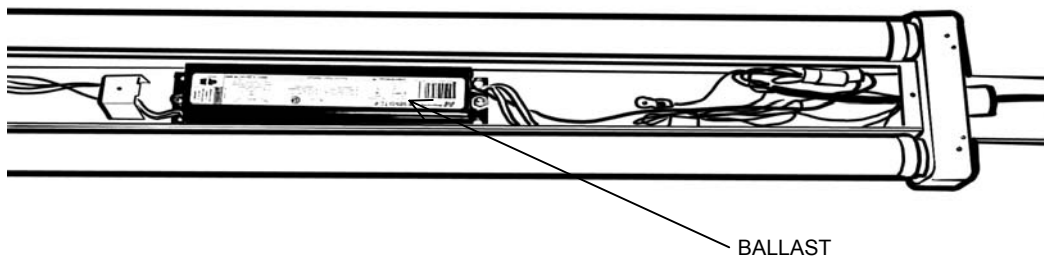

Figure 5. Lamp Assembly.

Removable Fixture Ballast Replacement: Remove the machine screw from the access plate and remove the plate. Label and disconnect the ballast wires. Remove the four machine screws from the ballast plate and remove the ballast.

Install the replacement ballast and connect wires and wire nuts. Attach the access plate and tighten the machine screw.

Power cord: Remove the machine screw from the access plate and remove the plate. Label and disconnect the power cord wires. Install a replacement power cord, connect wires and wire nuts. Attach access plate and tighten machine screw.

Emergency Light Battery/Charger: Turn off lighting system circuit breaker #19 on the Power Distribution Panel. Remove the access panel and the connector at the test switch and lamp. Label and disconnect the wires connected to the battery/charger. Remove the hardware and battery/charger from the fixture.

Install the replacement battery/charger, lamp and test switch. Connect wires, wire nuts and connector to the test switch and lamp. Attach access plate and tighten machine screw.

END OF WORK PACKAGE

CHAPTER 5

**DIRECT SUPPORT MAINTENANCE PROCEDURES
FOR
CONTAINERIZED KITCHEN (WITH TRAILER) [CK]**

**CONTAINERIZED KITCHEN (WITH TRAILER)
DIRECT SUPPORT MAINTENANCE PROCEDURES**

COOK CENTER**THIS WORK PACKAGE COVERS:**

Inspect, Repair

INITIAL SETUP

Kitchen set up, cook center not operating

Maintenance Level

Direct Support

Tools and Special Tools

Tool Kit, General Mechanic's (WP 0052 00, Table 1, Item 1)

Shop Equipment, Welding (WP 0052 00, Table 1, Item 2)

GENERAL

This procedure contains information and instructions to keep the cook center in good working order by inspecting and repairing its metal components and subassemblies.

INSPECT

Inspect the following cook center assemblies and components for bent or cracked sheet metal, cracked welds, and loose or missing rivets:

- Base assembly
- Griddle assembly (griddle top and splash guards)
- Steam table and adapter top
- Cook pot cradle adapters (4)
- Base rack
- Burner rack
- Cook pot cradles (2)
- Exhaust hood and grease filters

REPAIR

Perform welding operations as described in TM 9-237, Operator's Manual: Welding Theory and Application.

Replace loose or missing rivets and perform sheet metal repair as described in TM 9-510, Metal Body Repair and Related Operations.

END OF WORK PACKAGE

**CONTAINERIZED KITCHEN (WITH TRAILER)
DIRECT SUPPORT MAINTENANCE PROCEDURES**

OVEN ASSEMBLY**THIS WORK PACKAGE COVERS:**

Inspect, Repair

INITIAL SETUP

Oven shut down and cool

Maintenance Level

Direct Support

Tools and Special Tools

Tool Kit, General Mechanic's (WP 0052 00, Table 1, Item 1)

Shop Equipment, Welding (WP 0052 00, Table 1, Item 2)

GENERAL

This procedure contains information and instructions to keep the oven assembly in good working order by inspecting and repairing its metal components and subassemblies.

INSPECT

Inspect the following oven assembly components for bent or cracked sheet metal, cracked welds, and loose or missing rivets:

- Oven base assembly
- Oven fan assembly
- Oven racks

REPAIR

Perform welding operations as described in TM 9-237, Operator's Manual: Welding Theory and Application.

Replace loose or missing rivets and perform sheet metal repair as described in TM 9-510, Metal Body Repair and Related Operations.

END OF WORK PACKAGE

**CONTAINERIZED KITCHEN (WITH TRAILER)
DIRECT SUPPORT MAINTENANCE PROCEDURES**

TRAY PACK HEATER**THIS WORK PACKAGE COVERS:**

Inspect, Repair

INITIAL SETUP

Tray Pack Heater shut down, cool, drained

Maintenance Level

Direct Support

Tools and Special Tools

Tool Kit, General Mechanic's (WP 0052 00, Table 1, Item 1)

Shop Equipment, Welding (WP 0052 00, Table 1, Item 2)

GENERAL

This procedure contains information and instructions to keep the tray pack heater in good working order by inspecting and repairing its metal components and subassemblies.

INSPECT

Inspect the following tray pack heater components for bent or cracked sheet metal, cracked welds, and loose or missing rivets:

Tray pack heater

Heater base assembly

Heater fan assembly

REPAIR

Perform welding operations as described in TM 9-237, Operator's Manual: Welding Theory and Application.

Replace loose or missing rivets and perform sheet metal repair as described in TM 9-510, Metal Body Repair and Related Operations.

END OF WORK PACKAGE

**CONTAINERIZED KITCHEN (WITH TRAILER)
DIRECT SUPPORT MAINTENANCE PROCEDURES**

SHELTER ASSEMBLY/MECHANICAL ROOM**THIS WORK PACKAGE COVERS:**

Inspect, Repair

INITIAL SETUP

CK set up

Air conditioner removed (for air conditioner repair)

Maintenance Level

Direct Support

Tools and Special Tools

Tool Kit, General Mechanic's (WP 0052 00, Table 1, Item 1)

Shop Equipment, Welding (WP 0052 00, Table 1, Item 2)

GENERAL

This procedure contains information and instructions to keep the shelter assembly and mechanical room in good working order by inspecting and repairing its components and subassemblies.

INSPECT

Inspect the following shelter assembly components for bent or cracked sheet metal, cracked welds, and loose or missing rivets:

Stairs

Platform

Railings

REPAIR

Shelter Assembly: Perform welding operations as described in TM 9-237, Operator's Manual: Welding Theory and Application.

Replace loose or missing rivets and perform sheet metal repair as described in TM 9-510, Metal Body Repair and Related Operations.

Air Conditioner:

Remove and Replace Evaporator Blower Motor: Remove the air conditioner top cover (see Figure 1). Label and disconnect the evaporator blower motor wiring in the wire box. Slide the wiring harness through the side wall. Remove the hardware from the side panel and remove the evaporator blower assembly from the air conditioner.

Remove the four screws from the assembly cover and the three screws from the motor mounting bracket. Remove the blower motor from the assembly cover. Remove the blower wheel from the motor shaft.

CONTAINERIZED KITCHEN (WITH TRAILER) DIRECT SUPPORT MAINTENANCE PROCEDURES

Assemble the blower wheel to the shaft of the replacement blower motor. Tighten the set screw on the flat of the shaft. Assemble the motor mount onto the assembly cover. Tighten nuts. Ensure the blower wheel rotates freely without interference. Attach the ground wire between screw head and washer. Install the blower motor assembly into the air conditioner using the retained hardware. Reconnect the blower motor wiring in the wire box. Ensure the cable assembly is secure and will not contact any moving parts. Reinstall the top cover.

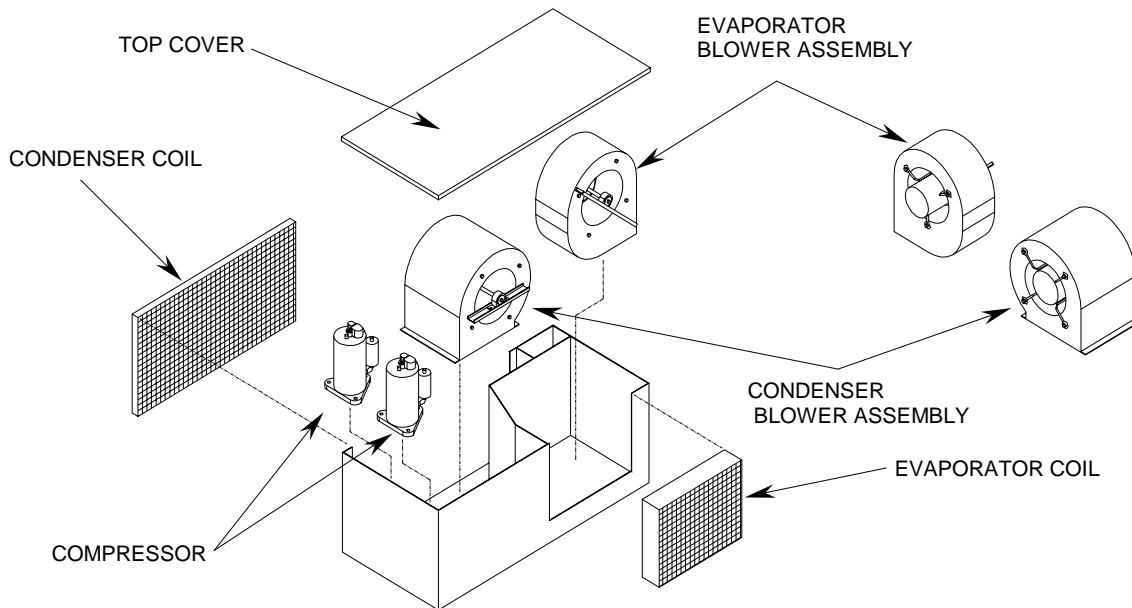

Figure 1. Air Conditioner Repair.

Remove and Replace Condenser Blower Motor: Remove the air conditioner top cover (see Figure 1). Remove the six nuts that attach the blower motor assembly to the side panel. Label and disconnect the condenser blower motor wiring. Remove the blower motor assembly from the air conditioner.

Remove the four screws from the assembly cover and the three screws from the motor mounting bracket. Remove the blower motor from the assembly cover. Remove the blower wheel from the motor shaft.

Assemble the blower wheel to the shaft of the replacement blower motor. Tighten the set screw on the flat of the shaft. Assemble the motor mount onto the assembly cover. Tighten nuts.

Ensure the blower wheel rotates freely without interference. Attach the ground wire between screw head and washer. Install the blower motor assembly into the air conditioner using the retained hardware. Reconnect the blower motor wiring. Ensure the cable assembly is secure and will not contact any moving parts. Reinstall the top cover.

END OF WORK PACKAGE

TM 10-7360-226-13&P

CHAPTER 6
SUPPORTING INFORMATION
FOR
CONTAINERIZED KITCHEN (WITH TRAILER) [CK]

CONTAINERIZED KITCHEN (WITH TRAILER) REFERENCES

SCOPE

This work package lists field manuals, forms, technical manuals, pamphlets and miscellaneous publications that are referenced in this manual or are otherwise applicable to the operation and maintenance of the CK.

FIELD MANUALS

Basic Doctrine for Army Field Feeding and Class I Operations Management	FM 10-23
First Aid for Soldiers	FM 21-11
Theater of Operations Electrical Systems.....	FM 5-424
Basic Cold Weather Manual	FM 31-70
Chemical and Biological Contamination Avoidance	FM 3-3
NBC Protection	FM 3-4
NBC Decontamination	FM 3-5

FORMS

Equipment Control Record	DA Form 2408-9
Equipment Inspection and Maintenance Worksheet	DA Form 2404
Hand Receipt	DA Form 2062
Product Quality Deficiency Report.....	SF 368
Recommended Changes to Publications and Blank Forms	DA Form 2028
Recommended Changes to Equipment Technical Publications	DA Form 2028-2
Transportation Discrepancy Report	SF 361

TECHNICAL MANUALS

Destruction of Army Equipment to Prevent Enemy Use (Mobility Equipment Command)	TM 750-244-3
Administrative Storage of Equipment.....	TM 740-90-1
Preservation, Packaging, and Packing of Military Supplies and Equipment.....	TM 38-230-2
Welding Theory and Application	TM 9-237
Metal Body Repair and Related Operation	TM 9-510
Operator's, Unit and Direct Support Maintenance Manual Including Repair Parts & Special Tools List for Modern Burner Unit	TM 10-7310-281-13&P
Operator's Manual for Generator Set, Skid Mounted, Tactical Quiet.....	TM 9-6115-642-10
Unit, Direct Support and General Support Maintenance Manual for Generator Set, Skid Mounted, Tactical Quiet.....	TM 9-6115-642-24
Operator's, Organizational, Direct Support, and General Support Maintenance (Including Repair Parts and Special Tools List) for Chassis, Containerized Kitchen Trailer: 7½ Ton, 4-Wheel XCK2000	TM 9-2330-328-14&P

**CONTAINERIZED KITCHEN (WITH TRAILER)
REFERENCES**

PAMPHLETS

Functional User's Manual for the Army

Maintenance Management System (TAMMS) DA PAM 738-750

MISCELLANEOUS PUBLICATIONS

Occupational and Environmental Health Food Service TB MED 530

Lubrication Order..... LO 9-6115-642-12

Common Table of Allowances, Expendable/Durable Items CTA 50-970

Common Table of Allowances, Army Medical Department

Expendable/Durable Items CTA 8-100

**CONTAINERIZED KITCHEN (WITH TRAILER)
INTRODUCTION FOR MAINTENANCE ALLOCATION CHART (MAC)**

The Army Maintenance System MAC

This introduction provides a general explanation of all maintenance and repair functions authorized at the two maintenance levels under the Two-Level Maintenance System concept.

The MAC (immediately following the introduction) designates overall authority and responsibility for the performance of maintenance functions on the identified end item or component. The application of the maintenance functions to the end item or component shall be consistent with the capacities and capabilities of the designated maintenance levels, which are shown on the MAC in column (4) as:

Field - includes two columns, Unit maintenance and Direct Support maintenance. The Unit maintenance column is divided again into two more subcolumns, C for Operator or Crew and O for Unit maintenance.

Sustainment – includes two subcolumns, General Support (H) and Depot (D)

The tools and test equipment requirements (immediately following the MAC) list the tools and test equipment (both special tools and common tool sets) required for each maintenance function as referenced from the MAC. The remarks (immediately following the tools and test equipment requirements) contain supplemental instructions and explanatory notes for a particular maintenance function.

Maintenance Functions

Maintenance functions are limited to and defined as follows:

1. Inspect. To determine the serviceability of an item by comparing its physical, mechanical, and/or electrical characteristics with established standards through examination (e.g., by sight, sound, or feel.) This includes scheduled inspection and gagings and evaluation of cannon tubes.
2. Test. To verify serviceability by measuring the mechanical, pneumatic, hydraulic, or electrical characteristics of an item and comparing those characteristics with prescribed standards on a scheduled basis, i.e., load testing of lift devices and hydrostatic testing of pressure hoses.
3. Service. Operations required periodically to keep an item in proper operating condition, e.g. to clean (includes decontaminate, when required), to preserve, to drain, to paint, or to replenish fuel, lubricants, chemical fluids, or gases. This includes scheduled exercising and purging of recoil mechanisms. The following are examples of service functions:
 - a. Unpack. To remove from packing box for service or when required for the performance of maintenance operations.
 - b. Repack. To return item to packing box after service and other maintenance operations.
 - c. Clean. To rid the item of contamination.

CONTAINERIZED KITCHEN (WITH TRAILER)
INTRODUCTION FOR MAINTENANCE ALLOCATION CHART (MAC)

- d. Touch up. To spot paint scratched or blistered surfaces.
 - e. Mark. To restore obliterated identification.
4. Adjust. To maintain or regulate, within prescribed limits, by bringing into proper or position, or by setting the operating characteristics to specified parameters.
 5. Align. To adjust specified variable elements of an item to bring about optimum or desired performance
 6. Calibrate. To determine and cause corrections to be made or to be adjusted on instruments of test, measuring, and diagnostic equipment used in precision measurement. Consists of comparisons of two instruments, one of which is a certified standard of known accuracy, to detect and adjust any discrepancy in the accuracy of the instrument being compared.
 7. Remove/install. To remove and install the same item when required to perform service or other maintenance functions. Install may be the act of emplacing, seating, or fixing into position a spare, repair part, or module (component or assembly) in a manner to allow the proper functioning of an equipment or system.
 8. Paint. To prepare and spray color coats of paint so that the ammunition can be identified and protected. The color indicating primary use is applied, preferably, to the entire exterior surface as the background color of the item. Other markings are to be repainted as original so as to retain proper ammunition identification.
 9. Replace. To remove an unserviceable item and install a serviceable counterpart in its place. "Replace" is authorized by the MAC and assigned maintenance level is shown as the third position code of the Source, Maintenance and Recoverability (SMR) code.
 10. Repair. The application of maintenance services, including fault location/troubleshooting, removal/installation, disassembly/assembly procedures and maintenance actions to identify troubles and restore serviceability to an item by correcting specific damage, fault, malfunction, or failure in a part, subassembly, module (component or assembly), end item, or system.

NOTE

The following definitions are applicable to the "repair" maintenance function:

Services. Inspect, test, service, adjust, align, calibrate, and/or replace.

Fault location/troubleshooting. The process of investigating and detecting the cause of equipment malfunctioning; the act of isolating a fault within a system or Unit Under Test (UUT).

Disassembly/assembly. The step by step breakdown (taking apart) of a spare/functional group coded item to the level of its least component, that is assigned an SMR code for the level of maintenance under consideration (i.e. identified as maintenance significant).

Actions. Welding, grinding, riveting, straightening, facing, machining, and/or resurfacing.

CONTAINERIZED KITCHEN (WITH TRAILER)
INTRODUCTION FOR MAINTENANCE ALLOCATION CHART (MAC)

11. Overhaul. That maintenance effort (service/action) prescribed to restore an item to a completely serviceable/operational condition as required by maintenance standards in appropriate technical publications. Overhaul is normally the highest degree of maintenance performed by the Army. Overhaul does not normally return an item to like new condition.
12. Rebuild. Consists of those services/actions necessary for the restoration of unserviceable equipment to a like new condition in accordance with original manufacturing standards. Rebuild is the highest degree of material maintenance applied to Army equipment. The rebuild operation includes the act of returning to zero those age measurements (e.g., hours/miles) considered in classifying Army equipment/components.

Explanation of Columns in the MAC

Column (1) Group Number. Column (1) lists Functional Group Code (FGC) numbers, the purpose of which is to identify maintenance significant components, assemblies, subassemblies, and modules with the Next Higher Assembly (NHA).

Column (2) Component/Assembly. Column (2) contains the item names of components, assemblies, subassemblies, and modules for which maintenance is authorized.

Column (3) Maintenance Function. Column (3) lists the functions to be performed on the item listed in column (2). (For a detailed explanation of these functions refer to "Maintenance Functions" outlined above).

Column (4) Maintenance Level. Column (4) specifies each level of maintenance authorized to perform each function listed in column (3), by indicating work time required (expressed as manhours in whole hours or decimals) in the appropriate subcolumn. This work time figure represents the active time required to perform that maintenance function at the indicated level of maintenance. If the number or complexity of the tasks within the listed maintenance function varies at different maintenance levels, appropriate work time figures are to be shown for each level. The work time figure represents the average time required to restore an item (assembly, subassembly, component, module, end item, or system) to a serviceable condition under typical field operating conditions. This time includes preparation time (including any necessary disassembly/assembly time), troubleshooting/fault location time, and quality assurance time in addition to the time required to perform the specific tasks identified for the maintenance functions authorized in the MAC. The symbol designations for the various maintenance levels are as follows:

Field:

- C Operator or Crew maintenance
- O Unit maintenance
- F Direct Support maintenance

Sustainment:

- L Specialized Repair Activity
- H General Support maintenance
- D Depot maintenance

**CONTAINERIZED KITCHEN (WITH TRAILER)
INTRODUCTION FOR MAINTENANCE ALLOCATION CHART (MAC)**

NOTE

The "L" maintenance level is not included in column (4) of the MAC. Functions to this level of maintenance are identified by work time figure in the "H" column of column (4), and an associated reference code is used in the REMARKS column (6). This code is keyed to the remarks and the SRA complete repair application is explained there.

Column (5) Tools and Equipment Reference Code. Column (5) specifies, by code, those common tool sets (not individual tools), common Test, Measurement and Diagnostic Equipment (TMDE), and special tools, special TMDE, and support special equipment required to perform the designated function. Codes are keyed to the entries in the tools and test equipment table.

Column (6) Remarks Code. When applicable, this column contains a letter code, in alphabetic order, which is keyed to the remarks table entries.

Explanation of Columns in the Tools and Test Equipment Requirements

Column (1) – Tool or Test Equipment Reference Code. The tool or test equipment reference code correlates with a code used in column (5) of the MAC.

Column (2) – Maintenance Level. The lowest level of maintenance authorized to use the tool or test equipment.

Column (3) – Nomenclature. Name or identification of the tool or test equipment.

Column (4) – National Stock Number (NSN). The NSN of the tool or test equipment.

Column (5) – Tool Number. The manufacturer's part number.

Explanation of Columns in Remarks

Column (1) – Remarks Code. The code recorded in column (6) of the MAC.

Column (2) – Remarks. This column lists information pertinent to the maintenance function being performed as indicated in the MAC."

**CONTAINERIZED KITCHEN (WITH TRAILER)
MAINTENANCE ALLOCATION CHART (MAC)**

Table 1. MAC for CK

(1) GROUP NUMBER	(2) COMPONENT/ ASSEMBLY	(3) MAINTENANCE FUNCTION	(4) MAINTENANCE LEVEL					(5) TOOLS AND EQUIPMENT REFERENCE CODE	(6) REMARKS CODE	
			FIELD		SUSTAINMENT					
			UNIT		DIRECT SUPPORT	GENERAL SUPPORT	DEPOT			
			C	O	F	H	D			
00	CONTAINERIZED KITCHEN SHELTER							1,2		
01	TENTAGE	Inspect	0.3						Q	
		Repair		0.5						
		Replace		8.0						
0102	CONTAINER	Inspect	0.3						Z	
		Repair		0.5						
010201	WINCH/CABLE ASSEMBLY	Inspect	0.1	0.1						
		Replace		2.5					R	
010202	STAIRS/RAILING	Inspect	0.2		0.3	0.5			A,V	
		Repair							Q	
010203	AWNING ASSEMBLY	Inspect	0.1							
		Replace		0.5						
010204	JACKS	Inspect	0.2						W	
		Repair		0.5						
010205	EXTERIOR DRAIN HOSE	Inspect	0.1						B	
		Repair		0.2						
02	MECHANICAL ROOM									
0201	EXHAUST PIPE ASSEMBLY	Inspect	0.1						V	
		Repair			0.5					
0202	EXHAUST DUCTS (CLOTH)	Inspect	0.1						Q	
		Replace		0.3						
0203	ENVIRONMENTAL CONTROL UNIT									
020301	AIR CONDITIONERS	Inspect	0.1							
		Repair		0.3	2.0					
		Replace		0.6						
020302	ECU CONTROL BOX	Inspect	0.1							
		Repair		0.3						

**CONTAINERIZED KITCHEN (WITH TRAILER)
MAINTENANCE ALLOCATION CHART (MAC)**

Table 1. MAC for CK – Continued

(1) GROUP NUMBER	(2) COMPONENT/ ASSEMBLY	(3) MAINTENANCE FUNCTION	(4) MAINTENANCE LEVEL					(5) TOOLS AND EQUIPMENT REFERENCE CODE	(6) REMARKS CODE	
			FIELD		SUSTAINMENT					
			UNIT		DIRECT SUPPORT	GENERAL SUPPORT	DEPOT			
			C	O	F	H	D			
020303	ECU CONTROL SWITCH ASSEMBLY	Inspect	0.1	0.1						
		Repair		0.5						
0204	INTAKE FAN	Inspect	0.1							
		Replace		1.0						
0205	EXHAUST FAN	Inspect	0.1							
		Replace		1.0						
03	COOK CENTER GRIDDLE ASSEMBLY	Inspect	0.1					A,V		
0301		Repair		0.4	0.6					
0302	STEAM TABLE & ADAPTER TOP	Inspect	0.1					A,V		
0303		Repair		0.5	1.0					
	0304	COOK POT CRADLE ADAPTER	Inspect	0.1					A,U,V	
Repair				0.3	0.5					
03041	COOK POT CRADLE ASSEMBLY BASE RACK	Inspect	0.1					A,V		
03042		Repair		0.2	0.5					
	03043	BURNER RACK	Inspect	0.1					A,V	
Repair				0.2	0.5					
03044	COOK POT CRADLE	Inspect	0.1					A,U,V		
		Repair		0.2	0.5					
0305	FUEL LINE ASSEMBLY	Inspect	0.1					A,T		
		Replace		0.5						
0306	24 VDC POWER CABLE ASSEMBLY	Inspect	0.1					C		
		Repair		0.3						
		Replace		0.5						

**CONTAINERIZED KITCHEN (WITH TRAILER)
MAINTENANCE ALLOCATION CHART (MAC)**

Table 1. MAC for CK – Continued

(1) GROUP NUMBER	(2) COMPONENT/ ASSEMBLY	(3) MAINTENANCE FUNCTION	(4) MAINTENANCE LEVEL					(5) TOOLS AND EQUIPMENT REFERENCE CODE	(6) REMARKS CODE
			FIELD			SUSTAINMENT			
			UNIT		DIRECT SUPPORT	GENERAL SUPPORT	DEPOT		
			C	O	F	H	D		
0307	BASE ASSEMBLY	Inspect	0.2					A,H	
		Repair		0.4	1.2				
04	EXHAUST HOOD	Inspect	0.1					A,U,V	
		Repair		0.5	0.5				
05	OVEN ASSEMBLY								
0501	OVEN	Inspect	0.1					A,U,V	
		Repair		0.3	0.5				
		Replace		0.5					
0502	OVEN FAN ASSEMBLY	Inspect	0.1						
		Repair		0.2	0.3			A,E,U	
0503	FUEL LINE ASSEMBLY	Inspect	0.1					T	
		Replace		0.5					
0504	24 VDC, 120 VAC POWER CABLE ASSEMBLIES	Inspect	0.1					C	
		Repair		0.3					
		Replace		0.5					
0505	OVEN BASE ASSEMBLY	Inspect	0.1	0.2				A,V	
		Repair		0.3	0.5				
06	MOBILE WARMING CABINET	Inspect	0.1					A,D,X	
		Repair		0.5					
		Replace		0.5					
07	REFRIGERATORS	Inspect	0.1					A,D	
		Repair			0.5				
08	TRAY PACK HEATER	Inspect	0.2	0.3				A,G,U,V	
		Repair		0.5	0.5				
0801	HEATER FAN ASSEMBLY	Inspect	0.1					A,C,U	
		Repair		0.4	0.4				
09	HAND SINK ASSEMBLY								
0901	CABINET ASSEMBLY	Inspect	0.1					A,I	
		Repair		0.4				A,H	
0902	WATER HEATER	Inspect	0.1					J	
		Replace			0.7				
0903	WATER PUMP	Inspect	0.1					K	
		Replace		0.5					

**CONTAINERIZED KITCHEN (WITH TRAILER)
MAINTENANCE ALLOCATION CHART (MAC)**

Table 1. MAC for CK – Continued

(1) GROUP NUMBER	(2) COMPONENT/ ASSEMBLY	(3) MAINTENANCE FUNCTION	(4) MAINTENANCE LEVEL					(5) TOOLS AND EQUIPMENT REFERENCE CODE	(6) REMARKS CODE
			FIELD		SUSTAINMENT				
			UNIT		DIRECT SUPPORT	GENERAL SUPPORT	DEPOT		
			C	O	F	H	D		
0904	SINK	Inspect	0.1	0.2				S	
		Replace		0.5					
09041	FAUCET	Inspect	0.1					L	
		Repair		0.5					
		Replace		0.5					
0905	WATER SUPPLY HOSES	Inspect	0.1					B	
		Repair		0.2					
0906	INTERIOR DRAIN HOSE	Inspect	0.1					B	
		Repair		0.2					
10	MOBILE STORAGE CABINETS	Inspect	0.1					A,V	
		Repair		05	1.0				
11	PREP/SERVING TABLES	Inspect	0.1					A	
		Repair	0.3						
12	ELECTRICAL SYSTEM								
	POWER ENTRANCE PANEL	Inspect	0.1	0.3				Y	
		Repair		0.7					
1202	POWER DISTRIBUTION PANEL	Inspect	0.1	0.3				N	
		Replace		0.7					
1203	MAIN CONTROL PANEL	Inspect	0.1	0.3				C,M	
		Replace		0.3					
1204	APPLIANCE CONTROL BOX	Inspect	0.1	0.3				C,M,N	
		Repair		0.5					
		Replace		0.5					
1205	MBU POWER SWITCH ASSEMBLY	Inspect	0.1	0.3				C,M	
		Replace		0.5					

**CONTAINERIZED KITCHEN (WITH TRAILER)
MAINTENANCE ALLOCATION CHART (MAC)**

Table 1. MAC for CK – Continued

(1) GROUP NUMBER	(2) COMPONENT/ ASSEMBLY	(3) MAINTENANCE FUNCTION	(4) MAINTENANCE LEVEL					(5) TOOLS AND EQUIPMENT REFERENCE CODE	(6) REMARKS CODE
			FIELD		SUSTAINMENT				
			UNIT		DIRECT SUPPORT	GENERAL SUPPORT	DEPOT		
			C	O	F	H	D		
1206	CEILING LIGHTS (FIXED)	Inspect	0.1	0.3					A,H
		Repair		0.5					
		Replace		0.5					
1207	CEILING LIGHTS (REMOVABLE)	Inspect	0.1	0.3					A,H
		Repair		0.5					
		Replace		0.5					

**CONTAINERIZED KITCHEN (WITH TRAILER)
MAINTENANCE ALLOCATION CHART (MAC)**
Table 2. Tools and Test Equipment for CK

(1) TOOLS OR TEST EQUIPMENT REFERENCE CODE	(2) MAINTENANCE LEVEL	(3) NOMENCLATURE	(4) NATIONAL STOCK NUMBER	(5) TOOL NUMBER
1	O	Tool Kit, General Mechanic's (GMTK)	5180-01-454-3787	
2	F	Shop Equipment, Welding	4940-01-090-1231	

Table 3. Remarks for CK

(1) REMARKS CODE	(2) REMARKS
A	General hardware repair at O level (tighten/replace hardware, straighten piece parts)
B	Washer replacement at O level
C	Cable/connector repair, replacement at O level
D	Caster replacement, connector repair, door gasket replacement at O level
E	Power cord replacement, motor replacement at O level
F	Replacement of power cord, module, caster, temperature controller at O level
G	Drain cock replacement at O level
H	Ballast replacement, wiring repair at O level
I	Replacement of caster, towel dispenser, soap dispenser at O level
J	Replacement of power cord, water heater at O level
K	Replacement of power cord, water pump at O level
L	Hot, cold faucet washer replacement, faucet replacement at O level
M	Switch replacement at O level
N	Circuit breaker replacement at O level
O	PC board replacement at O level
P	Converter replacement at O level
Q	Fabric repair at O level
R	Winch, cable replacement at O level
S	Drain repair, sink replacement at O level
T	Fuel line section replacement at O level
U	Rivet repair at DS level
V	Welding repair at DS level
W	Shear pin replacement at O level
X	Temperature control module replacement at O level
Y	Power connector, ground terminal, contractor replacement at O level
Z	Cam-lock replacement at O level

CONTAINERIZED KITCHEN (CK)
INTRODUCTION TO REPAIR PARTS & SPECIAL TOOLS LIST

SCOPE

This Repair Parts & Special Tools List (RPSTL) lists and authorizes spares and repair parts; special tools; special test, measurement, and diagnostic equipment (TMDE); and other special support equipment required for performance of Operator, Unit, and Direct Support maintenance of the Containerized Kitchen (CK). It authorizes the requisitioning, issue, and disposition of spares, repair parts, and special tools as indicated by the source, maintenance, and recoverability (SMR) codes.

GENERAL

In addition to the Introduction work package, this RPSTL is divided into the following work packages:

1. Repair Parts List Work Packages. Work packages containing lists of spares and repair parts authorized by this RPSTL for use in the performance of maintenance. These work packages also include parts which must be removed for replacement of the authorized parts. Parts lists are composed of functional groups in ascending alphanumeric sequence, with the parts in each group listed in ascending figure and item number sequence. Sending units, brackets, filters, and bolts are listed with the component they mount on. Bulk materials are listed by item name in FIG. BULK at the end of the work packages. Repair parts kits are listed separately in their own functional group and work package. Repair parts for reparable special tools are also listed in a separate work package. Items listed are shown on the associated illustrations.
2. Special Tools List Work Packages. Work packages containing lists of special tools, special TMDE, and special support equipment authorized by this RPSTL (as indicated by Basis of Issue (BOI) information in the DESCRIPTION AND USABLE ON CODE (UOC) column). Tools that are components of common tool sets and/or Class VII are not listed.
3. Cross-Reference Indexes Work Packages. There are two cross-reference indexes work packages in this RPSTL: the National Stock Number (NSN) Index work package and the Part Number (P/N) Index work package. The National Stock Number Index work package refers you to the figure and item number. The Part Number Index work package refers you to the figure and item number.

EXPLANATION OF COLUMNS IN THE REPAIR PARTS LIST AND SPECIAL TOOLS LIST WORK PACKAGES

ITEM NO. (Column (1)). Indicates the number used to identify items called out in the illustration.

SMR CODE (Column (2)). The SMR code containing supply/requisitioning information, maintenance level authorization criteria, and disposition instructions, as shown in the following breakout:

CONTAINERIZED KITCHEN (CK)
INTRODUCTION TO REPAIR PARTS & SPECIAL TOOLS LIST

<u>Source Code</u>	<u>Maintenance Code</u>	<u>Recoverability Code</u>
XX	XX	X
1 st two positions: How to get an item.	3 rd position: Who can install, replace, or use the item	4 th position: Who can do complete repair* on the item
		5 th position: Who determines disposition action on unserviceable items.

*Complete Repair: Maintenance capacity, capability, and authority to perform all corrective maintenance tasks of the "Repair" function in a use/user environment in order to restore serviceability to a failed item.

Source Code. The source code tells you how you get an item needed for maintenance, repair, or overhaul of an end item/equipment. Explanations of source codes follow:

Source Code

PA
PB
PC
PD
PE
PF
PG

Application/Explanation

Stock items; use the applicable NSN to requisition/request items with these source codes. They are authorized to the level indicated by the code entered in the 3rd position of the SMR code.

NOTE

Items coded PC are subject to deterioration.

KD
KF
KB

Items with these codes are not to be requested/requisitioned individually. They are part of a kit which is authorized to the maintenance level indicated in the 3rd position of the SMR code. The complete kit must be requisitioned and applied.

MO – Made at unit/AVUM level
MF – Made at DS/AVIM level
MH – Made at GS level
ML – Made at SRA
MD – Made at depot

Items with these codes are not to be requisitioned/requested individually. They must be made from bulk material which is identified by the P/N in the DESCRIPTION AND USABLE ON CODE (UOC) column and listed in the bulk material group work package of the RPSTL. If the item is authorized to you by the 3rd position code of the SMR code, but the source code indicates it is made at higher level, order the item from the higher level of maintenance.

**CONTAINERIZED KITCHEN (CK)
INTRODUCTION TO REPAIR PARTS & SPECIAL TOOLS LIST**

Source Code

AO – Assembled by unit/AVUM level
 AF – Assembled by DS/AVIM level
 AH – Assembled by GS level
 AL – Assembled by SFA
 AD – Assembled by depot

Application/Explanation

Items with these codes are not to be requested/requisitioned individually. The parts that make up the assembled item must be requisitioned or fabricated and assembled at the level of maintenance indicated by the source code. If the 3rd position of the SMR code authorizes you to replace the item, but the source code indicates the item is assembled at a higher level, order the item from the higher level of maintenance.

XA

Do not requisition an “XA” coded item. Order the next higher assembly. (Refer to NOTE below).

XB

If an item is not available from salvage, order it using the CAGEC and P/N.

XC

Installation drawings, diagrams, instruction sheets, field service drawings; identified by manufacturer’s P/N.

XD

Item is not stocked. Order an XD-coded item through normal supply channels using the CAGEC and P/N given, if no NSN is available.

NOTE

Cannibalization or controlled exchange, when authorized, may be used as a source of supply for items with the above source codes except for those items source coded “XA” or those aircraft support items restricted by requirements of AR 750-1.

Maintenance Code. Maintenance codes tell you the level(s) of maintenance authorized to use and repair support items. The maintenance codes are entered in the third and fourth positions of the SMR code as follows:

Third Position. The maintenance code entered in the third position tells you the lowest maintenance level authorized to remove, replace, and use an item. The maintenance code entered in the third position will indicate authorization to the following levels of maintenance:

Maintenance Code

Application/Explanation

C

Crew or operator maintenance done within unit/AVUM maintenance.

O

Unit level/AVUM maintenance can remove, replace, and use the item.

F

Direct support/AVIM maintenance can remove, replace, and use the item.

**CONTAINERIZED KITCHEN (CK)
INTRODUCTION TO REPAIR PARTS & SPECIAL TOOLS LIST**

0033 00

<u>Source Code</u>	<u>Application/Explanation</u>
H	General support maintenance can remove, replace, and use the item.
L	Specialized repair activity can remove, replace, and use the item.
D	Depot can remove, replace, and use the item.

Fourth Position. The maintenance code entered in the fourth position tells you whether or not the item is to be repaired and identifies the lowest maintenance level with the capability to do complete repair (perform all authorized repair functions).

NOTE

Some limited repair may be done on the item at a lower level of maintenance, if authorized by the Maintenance Allocation Chart (MAC) and SMR codes.

<u>Maintenance Code</u>	<u>Application/Explanation</u>
O	Unit/AVUM is the lowest level that can do complete repair of the item.
F	Direct support/AVIM is the lowest level that can do complete repair of the item.
H	General support is the lowest level that can do complete repair of the item.
L	Specialized Repair Activity (SRA) is the lowest level that can do complete repair of the item.
D	Depot is the lowest level that can do complete repair of the item.
Z	Nonreparable. No repair is authorized.
B	No repair is authorized. No parts or special tools are authorized for maintenance of "B" coded items. However, the items may be reconditioned by adjusting, lubricating, etc., at the user level.

CONTAINERIZED KITCHEN (CK)
INTRODUCTION TO REPAIR PARTS & SPECIAL TOOLS LIST

Recoverability Code. Recoverability codes are assigned to items to indicate the disposition action on unserviceable items. The recoverability code is shown in the fifth position of the SMR code as follows:

<u>Recoverability Code</u>	<u>Application/Explanation</u>
Z	Nonreparable item. When unserviceable, condemn and dispose of the item at the level of maintenance shown in the third position of the SMR code.
O	Reparable item. When uneconomically reparable, condemn and dispose of the item at the unit level.
F	Reparable item. When uneconomically reparable, condemn and dispose of the item at the direct support level.
H	Reparable item. When uneconomically reparable, condemn and dispose of the item at the general support level.
D	Reparable item. When beyond lower level repair capability, return to depot. Condemnation and disposal of item are not authorized below depot level.
L	Reparable item. Condemnation and disposal not authorized below Specialized Repair Activity (SRA).
A	Items requires special handling or condemnation procedures because of specific reasons (such as precious metal content, high dollar value, critical material, or hazardous material). Refer to appropriate manuals/directives for specific instructions.

NSN Column (3)). The NSN for the item is listed in this column.

CAGEC (Column (4)). The Commercial and Government Entity Code (CAGEC) is a five-digit code which is used to identify the manufacturer, distributor, or Government agency/activity that supplies the item.

PART NUMBER (Column (5)). Indicates the primary number used by the manufacturer (individual, company, firm, corporation, or Government activity), which controls the design and characteristics of the item by means of its engineering drawings, specifications, standards, and inspection requirements to identify an item or range of items.

NOTE

When you use an NSN to requisition an item, the item you receive may have a different P/N from the number listed.

CONTAINERIZED KITCHEN (CK)
INTRODUCTION TO REPAIR PARTS & SPECIAL TOOLS LIST

0033 00

DESCRIPTION AND USABLE ON CODE (UOC) (Column (6)). This column includes the following information:

1. The federal item name, and when required, a minimum description to identify the item.
2. P/Ns of bulk materials are referenced in this column in the line entry to be manufactured or fabricated.
3. Hardness Critical Item (HCI). A support item that provides the equipment with special protection from electromagnetic pulse (EMP) damage during a nuclear attack.
4. The statement END OF FIGURE appears just below the last item description in column (6) for a given figure in both the repair parts list and special tools list work packages.

QTY (Column (7)). The QTY (quantity per figure) column indicates the quantity of the item used in the breakout shown on the illustration/figure, which is prepared for a functional group, subfunctional group, or an assembly. A "V" appearing in this column instead of a quantity indicates that the quantity is variable and quantity may change from application to application.

EXPLANATION OF CROSS-REFERENCE INDEXES WORK PACKAGES FORMAT AND COLUMNS.

1. National Stock Number (NSN) Index Work Package.

STOCK NUMBER Column. This column lists the NSN in National Item Identification Number (NIIN) sequence. The NIIN consists of the last nine digits of the NSN. When using this column to locate an item, ignore the first four digits of the NSN. However, the complete NSN should be used when ordering items by stock number.

FIG. Column. This column lists the number of the figure where the item is identified/located. The figures are in numerical order in the repair parts list and special tools list work packages.

ITEM Column. The item number identifies the item associated with the figure listed in the adjacent FIG. Column. This item is also identified by the NSN listed on the same line.

2. Part Number (P/N) Index Work Package. P/Ns in this index are listed in ascending alphanumeric sequence (vertical arrangement of letter and number combinations which places the first letter or digit of each group in order A through Z, followed by the numbers 0 through 9 and each following letter or digit in like order).

PART NUMBER Column. Indicates the P/N assigned to the item.

FIG. Column. This column lists the number of the figure where the item is identified/located in the repair parts list and special tools list work packages.

ITEM Column. The item number is the number assigned to the item as it appears in the figure referenced in the adjacent figure number column.

SPECIAL INFORMATION

CONTAINERIZED KITCHEN (CK)
INTRODUCTION TO REPAIR PARTS & SPECIAL TOOLS LIST

UOC. The UOC appears in the lower left corner of the Description Column heading. Usable on codes are shown as "UOC: . . ." in the Description Column (justified left) on the first line under the applicable item/nomenclature. Uncoded items are applicable to all models. Identification of the UOCs used in this RPSTL are: Not Applicable.

Fabrication Instructions. Bulk materials required to manufacture items are listed in the bulk material functional group of this RPSTL. Part numbers for bulk material are also referenced in the Description Column of the line item entry for the item to be manufactured/fabricated. Detailed fabrication instructions for items source coded to be manufactured or fabricated are found in: Not Applicable.

Index Numbers. Items which have the word BULK in the figure column will have an index number shown in the item number column. This index number is a cross-reference between the NSN and P/N index work packages and the bulk material list in the repair parts list work package.

Associated Publications. The publication(s) listed below pertain to the Containerized Kitchen:

<u>Publication</u>	<u>Title</u>
TM 10-7310-281-13&P	Operator's, Unit and Direct Support Maintenance Manual Including Repair Parts and Special Tools List for Modern Burner Unit
TM 9-6115-642-10	Operator's Manual, Generator Set, Skid Mounted, Tactical Quiet, 10 KW, 60 and 400 Hz
TM 9-6115-642-24	Unit, Direct Support and General Support Maintenance Manual for Generator Set, Skid Mounted, Tactical Quiet
TM 9-2330-328-14&P	Operator's, Organizational, Direct Support and General Support Maintenance Manual (Including Repair Parts and Special Tools Lists) for Chassis, Trailer

Illustrations List. The illustrations in this RPSTL contain unit and direct support authorized items. The tabular list in the repair parts list work package contains only those parts coded "O" and "F" in the third position of the SMR code, therefore, there may be a break in the item number sequence.

HOW TO LOCATE REPAIR PARTS**1. When NSNs or P/Ns Are Not Known.**

First. Using the table of contents, determine the assembly group to which the item belongs. This is necessary since figures are prepared for assembly groups and subassembly groups, and lists are divided into the same groups.

Second. Find the figure covering the functional group or the subfunctional group to which the item belongs.

Third. Identify the item on the figure and note the number(s).

Fourth. Look in the repair parts list work packages for the figure and item numbers. The NSNs and part numbers are on the same line as the associated item numbers.

2. When NSN Is Known.

First. If you have the NSN, look in the STOCK NUMBER column of the NSN index work package. The NSN is arranged in NIIN sequence. Note the figure and item number next to the NSN.

Second. Turn to the figure and locate the item number. Verify that the item is the one you are looking for.

3. When P/N Is Known.

First. If you have the P/N and not the NSN, look in the PART NUMBER column of the P/N index work package. Identify the figure and item number.

Second. Look up the item on the figure in the applicable repair parts list work package.

**CONTAINERIZED KITCHEN (WITH TRAILER)
GROUP 01 SHELTER ASSEMBLY
CONTAINER**

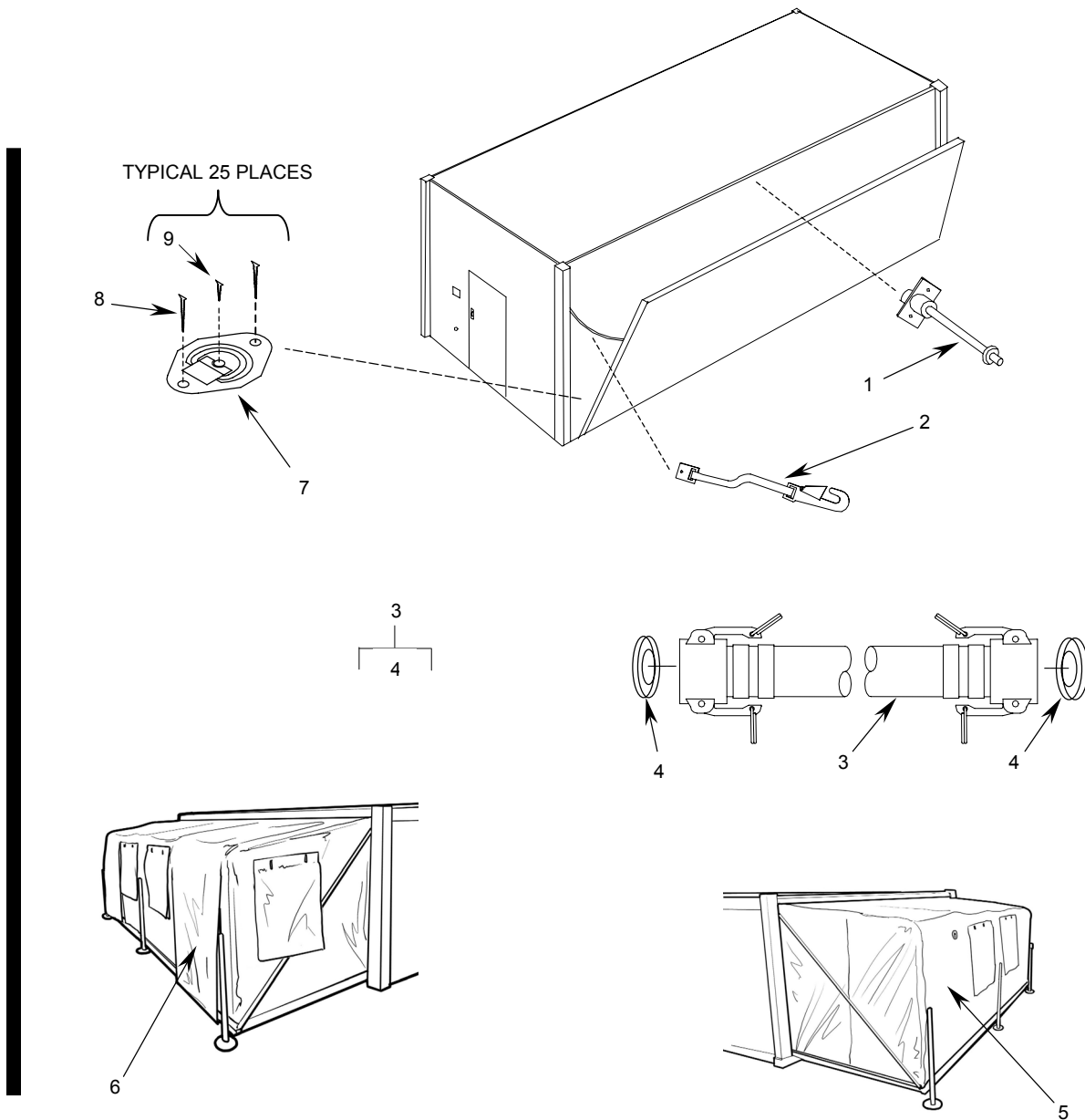

Figure 1. Container.

**GROUP 01 SHELTER ASSEMBLY
CONTAINER
REPAIR PARTS LIST**

(1) ITEM NO.	(2) SMR CODE	(3) NSN	(4) CAGEC	(5) PART NUMBER	(6) DESCRIPTION AND USABLE ON CODE (UOC)	(7) QTY
GROUP 01 SHELTER ASSEMBLY FIGURE 1 CONTAINER						
1	PAOZZ	5340-01-486-2238	80298	50389344	KICKER, SIDE	2
2	PAOZZ	5340-01-486-1936	80298	50389214	STRAP, SAFETY	2
3	PAOZZ	4720-01-486-4342	0U5N7	47011050-1	HOSE ASSEMBLY, EXTERNAL DRAIN	1
4	PAOZZ	5330-01-486-2809	7S077	B03	. GASKET, BUNA N.....	2
5	PAOZZ	8340-01-495-0449	0U5N7	47018028	FABRIC COVER, PREPARATION WING (GREEN).	1
5	PAOZZ	8340-01-515-2979	0U5N7	47018028-2TAN	FABRIC COVER, PREPARATION WING (TAN).....	1
6	PAOZZ	8340-01-495-0450	80298	60401008	FABRIC COVER, SERVING WING (GREEN).....	1
6	PAOZZ	8340-01-515-2981	80298	60401008-25TAN	FABRIC COVER, SERVING WING (TAN)	1
7	KFOZZ		00147	601-SS	TIE-DOWN PROVISION (PART OF KIT P/N 47017001)	1
8	KFOZZ		96906	MS51862-59C	.SCREW, TAPPING (PART OF KIT P/N47017001)	2
9	KFOZZ	5305-00-269-0770	96906	MS51862-56C	.SCREW, TAPPING (PART OF KIT P/N47017001)	1
	PAOOO	7360-01-516-0963	0U5N7	47017001	PARTS KIT, TIE-DOWN RING	25
				TIE-DOWN PROVISION (1) 1-7	
				SCREW, TAPPING (2) 1-8	
				SCREW, TAPPING (1) 1-9	
END OF FIGURE						

**CONTAINERIZED KITCHEN (WITH TRAILER)
GROUP 01 SHELTER ASSEMBLY
WINCH/CABLE/SHELTER FRAME ASSEMBLIES**

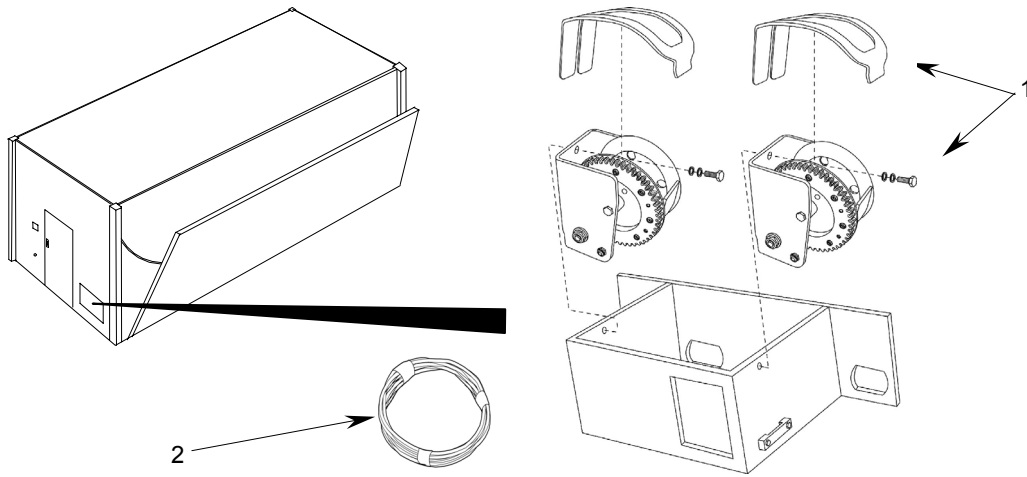

Figure 2. Winch/Cable Assembly.

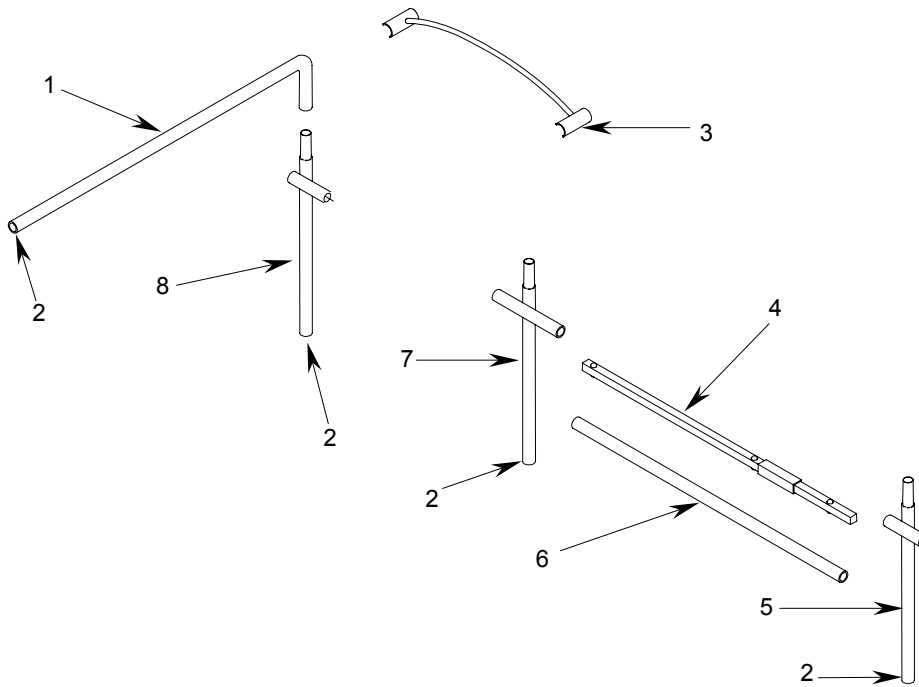

Figure 2A. Shelter Frame Assembly

**GROUP 01 SHELTER ASSEMBLY
WINCH/CABLE/SHELTER FRAME ASSEMBLIES
REPAIR PARTS LISTS**

(1) ITEM NO.	(2) SMR CODE	(3) NSN	(4) CAGEC	(5) PART NUMBER	(6) DESCRIPTION AND USABLE ON CODE (UOC)	(7) QTY
					GROUP 01 SHELTER ASSEMBLY FIGURE 2 WINCH/CABLE ASSEMBLY	
1	PAOZZ	3950-01-515-2999	80298	50389-201	ASSEMBLY, WINCH DRUM.....	2
2	PAOZZ	4010-01-486-3503	80298	50389-297	ROPE, WIRE	2
					END OF FIGURE	

(1) ITEM NO.	(2) SMR CODE	(3) NSN	(4) CAGEC	(5) PART NUMBER	(6) DESCRIPTION AND USABLE ON CODE (UOC)	(7) QTY
					GROUP 01 SHELTER ASSEMBLY FIGURE 2A SHELTER FRAME ASSEMBLY	
1	XDOZZ		80298	50389347	ARCH, SHELTER	1
2	PAOZZ	5340-01-492-3315	80298	50389357	CAP, PROTECTIVE, DUST AND MOISTURE	4
3	XDOZZ		80298	50389202	SPACER, ARCH, CURVED	1
4	XDOZZ		80298	50389351	SPACER, ARCH, ADJUSTABLE	1
5	XDOZZ		80298	50389349	VERTICLE "T", RIGHT SIDE	1
6	XDOZZ		80298	50389355	SPACER, ARCH	1
7	XDOZZ		80298	50389353	VERTICLE "X"	1
8	XDOZZ		80298	50389348	VERTICLE "T", LEFT SIDE.....	1
					END OF FIGURE	

**CONTAINERIZED KITCHEN (WITH TRAILER)
GROUP 01 SHELTER ASSEMBLY
JACKS**

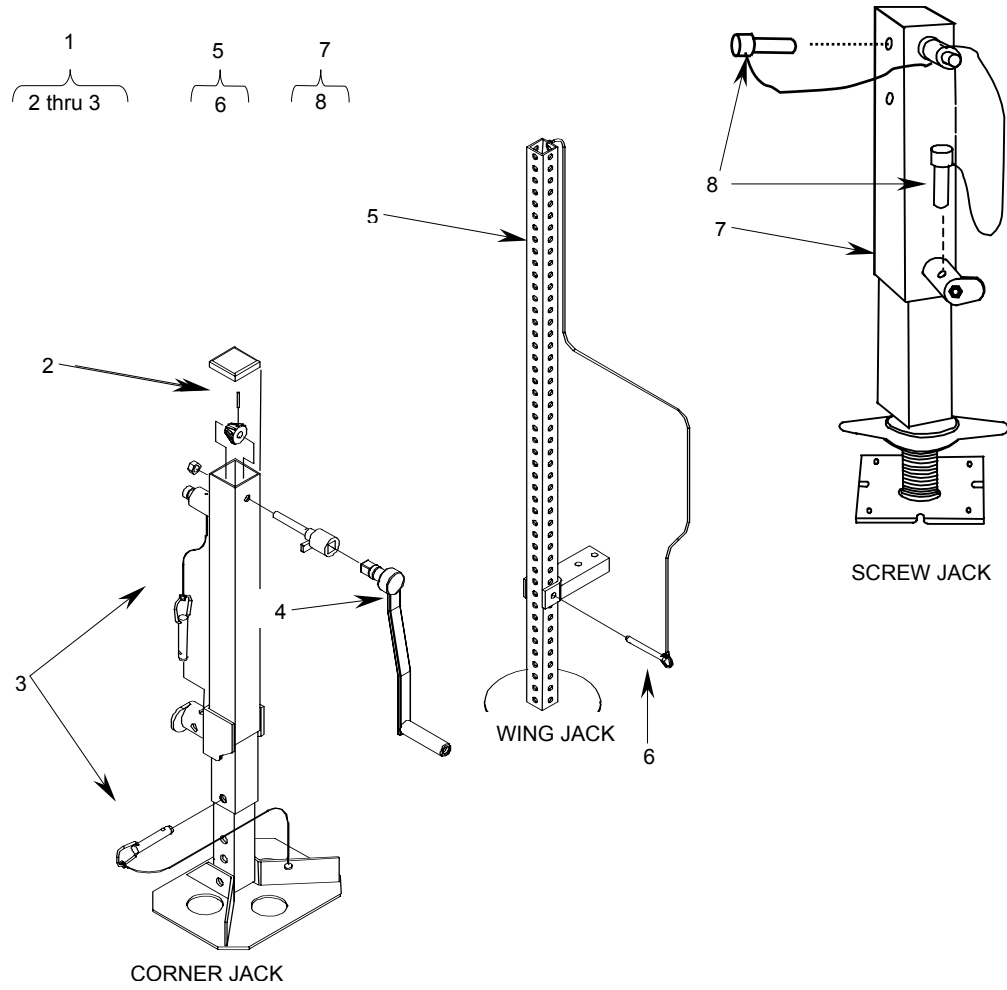

Figure 3. Jacks.

**GROUP 01 SHELTER ASSEMBLY
JACKS
REPAIR PARTS LIST**

(1) ITEM NO.	(2) SMR CODE	(3) NSN	(4) CAGEC	(5) PART NUMBER	(6) DESCRIPTION AND USABLE ON CODE (UOC)	(7) QTY
					GROUP 01 SHELTER ASSEMBLY FIGURE 3 JACKS	
1	XDOOO		80298	50389328	JACK, CORNER	2
2	PAOZZ	5306-01-486-1828	80298	50389341	PIN, SHEAR, CORNER JACK	1
3	PAOZZ	5315-01-486-2020	80298	50389299	PIN, ASSEMBLY, CORNER JACK	2
4	PAOZZ	5340-01-486-2219	80298	50389298	HANDLE, JACK/WINCH	1
5	PAOOO	5120-01-493-1762	80298	50389327	JACK, WING	8
6	PAOZZ	5315-01-486-2021	80298	50389343	PIN, ASSEMBLY, WING JACK	1
7	XDOOO		2C081	10291-JACK	JACK, SCREW	2
8	PAOZZ	5315-01-486-2498	80298	50389330	PIN, ASSEMBLY, SCREW JACK	2
					END OF FIGURE	

**GROUP 02 MECHANICAL ROOM
MECHANICAL ROOM ASSEMBLIES
REPAIR PARTS LIST**

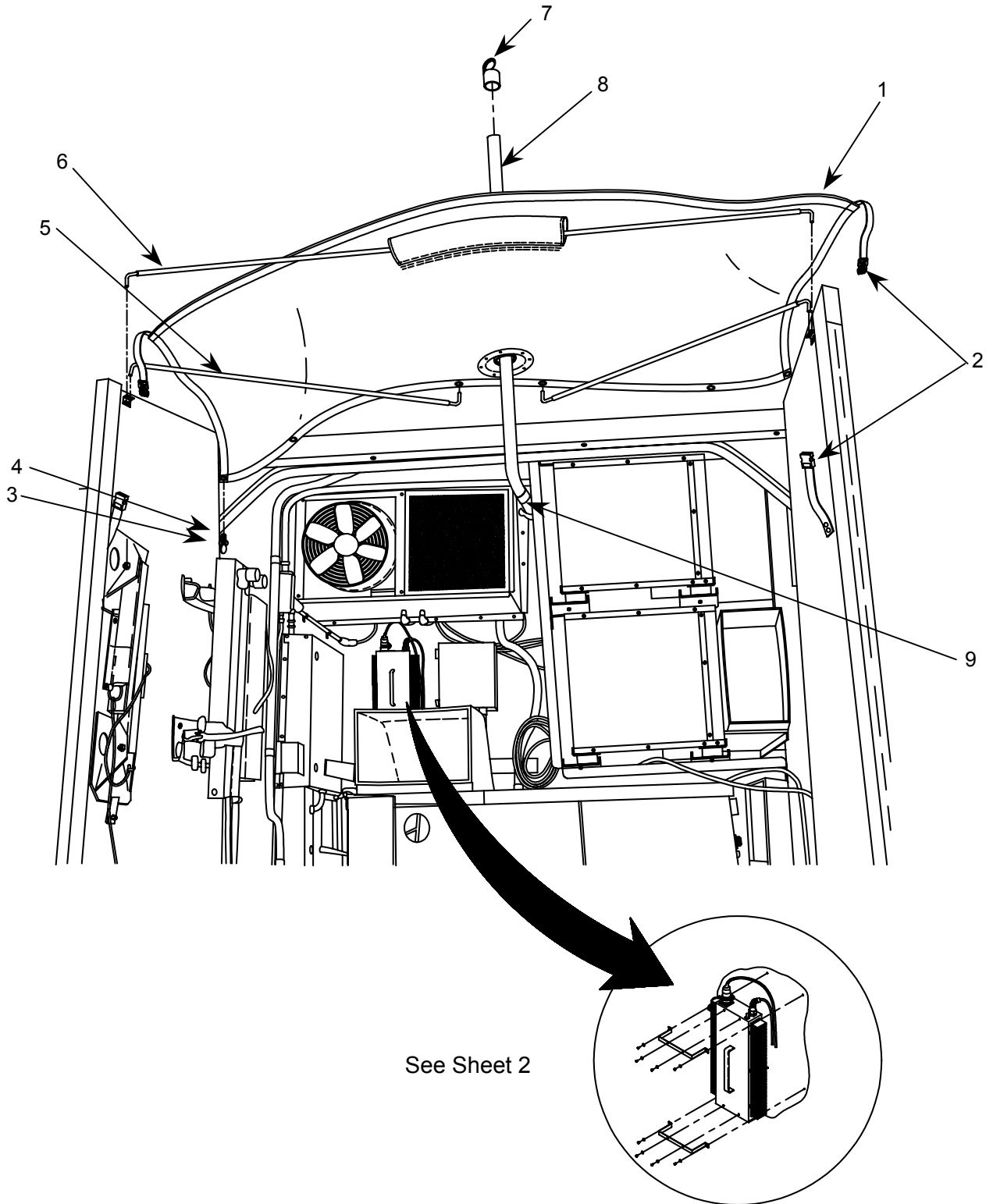

Figure 4. Mechanical Room Assemblies (Sheet 1 of 2)

CONTAINERIZED KITCHEN (WITH TRAILER)
GROUP 02 MECHANICAL ROOM
MECHANICAL ROOM ASSEMBLIES

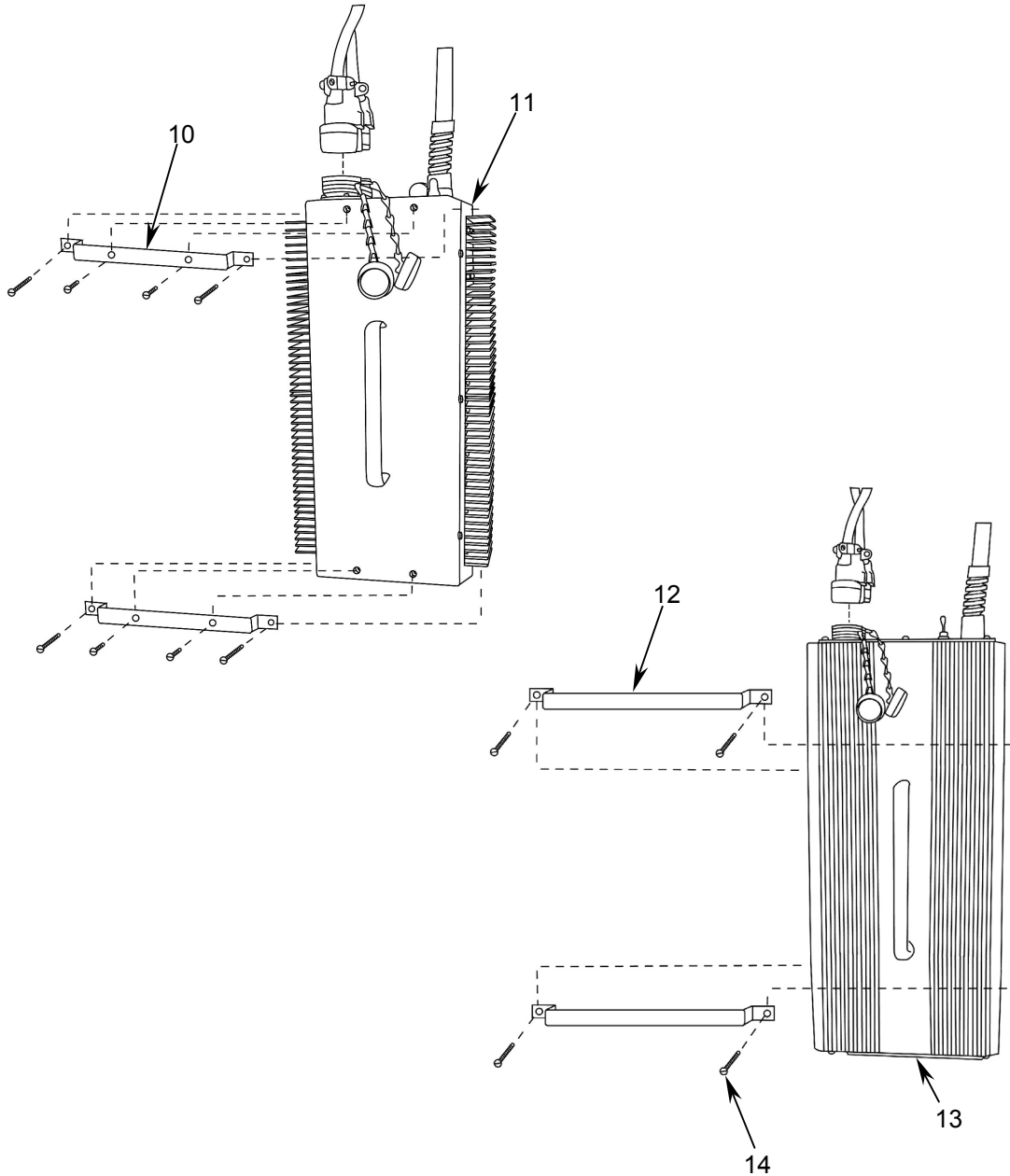

Figure 4. Mechanical Room Assemblies (Sheet 2 of 2)

**CONTAINERIZED KITCHEN (WITH TRAILER)
GROUP 02 MECHANICAL ROOM
MECHANICAL ROOM ASSEMBLIES**

(1) ITEM NO.	(2) SMR CODE	(3) NSN	(4) CAGEC	(5) PART NUMBER	(6) DESCRIPTION AND USABLE ON CODE (UOC)	(7) QTY
GROUP 02 MECHANICAL ROOM FIGURE 4 MECHANICAL ROOM ASSEMBLIES						
1	PAOZZ	7230-01-503-0230	0U5N7	47011056-1	AWNING, GREEN	1
1	PAOZZ	7230-01-515-2978	0U5N7	47011056-2	AWNING, TAN	1
2	PAOZZ	5340-01-378-9445	02768	101-0100-5614	BUCKLE.....	2
3	PAOZZ		39428	91744A583	THUMB SCREW.....	6
4	PAOZZ		39428	94800A730	RETAINER.....	6
5	PAOZZ	5340-01-519-2753	0U5N7	47012175	DOOR HOLDER, SHORT.....	2
6	PAOZZ	5340-01-519-2755	0U5N7	47012177	ROD, AWNING, LONG.....	1
7	PAOZZ	2990-01-486-3801	76700	89417A	CAP, RAIN	1
8	PAOZZ	4730-01-486-4235	0U5N7	47012265	ELBOW, EXHAUST	1
9	PAOZZ	4730-01-486-4366	39428	6815K13	COUPLING, PIPE, QUICK-LOCK.....	1
10	XDOZZ		0U5N7	47012196	BRACKET (USE WITH ITEM 11)	2
11	PAOFF	7310-01-453-6513	3AD06	MS0150	MBU POWER CONVERTER (OLD STYLE)	1
12	PAOZZ	5340-01-519-2751	0U5N7	47012383	BRACKET (USE WITH ITEM 13)	2
13	PAOFF	7310-01-502-9455	3AD06	MS0160	MBU POWER CONVERTER (NEW STYLE)	1
14	PAOZZ	5305-00-477-0122	96906	MS51861-47C	SCREW, TAPPING.....	4
END OF FIGURE						

**GROUP 02 MECHANICAL ROOM
ECU CONTROL BOX AND MODE SWITCH
REPAIR PARTS LIST**

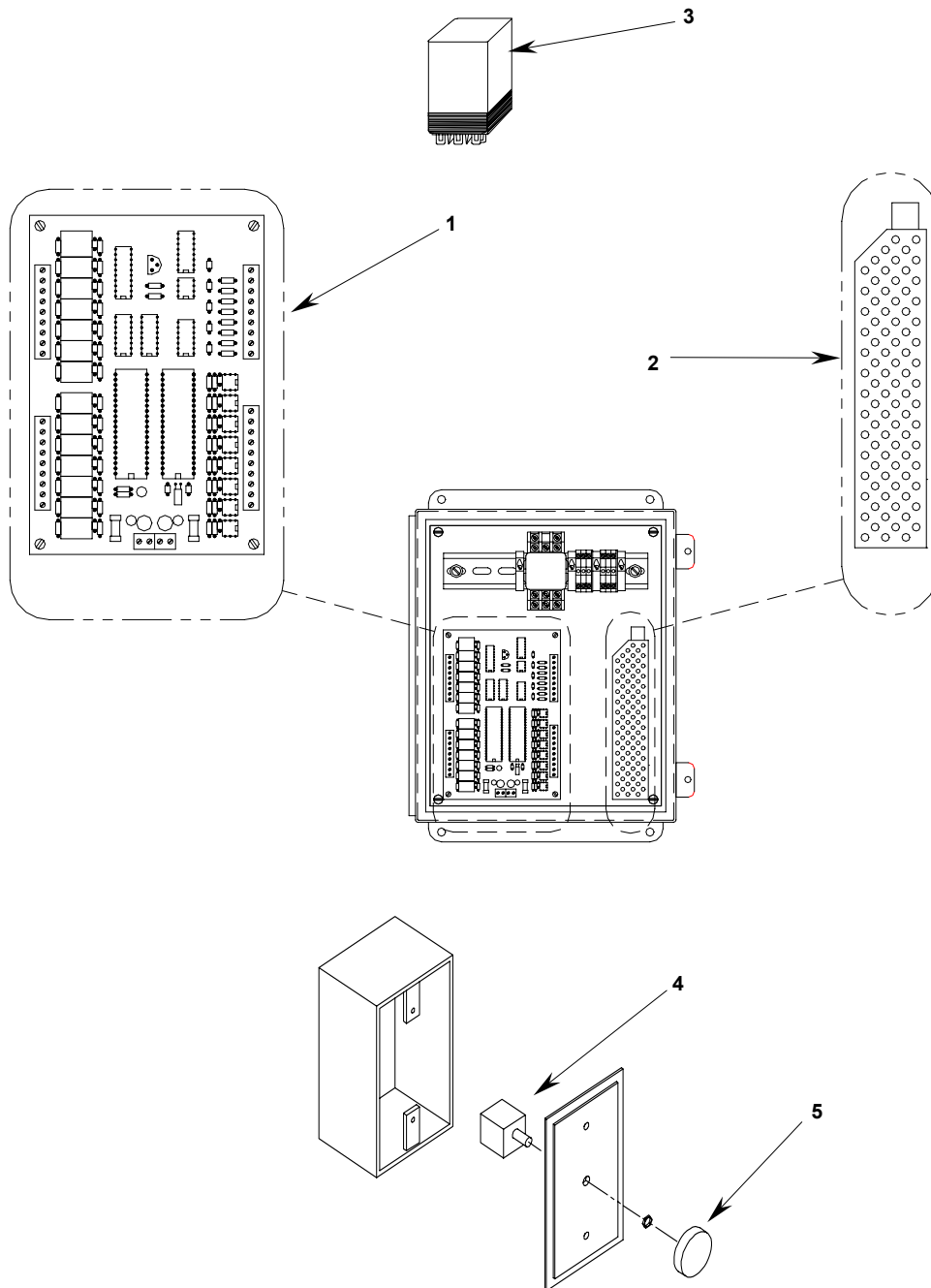

Figure 5. ECU Control Box And Mode Switch.

**CONTAINERIZED KITCHEN (WITH TRAILER)
 GROUP 02 MECHANICAL ROOM
 ECU CONTROL BOX AND MODE SWITCH**

(1) ITEM NO.	(2) SMR CODE	(3) NSN	(4) CAGEC	(5) PART NUMBER	(6) DESCRIPTION AND USABLE ON CODE (UOC)	(7) QTY
					GROUP 02 MECHANICAL ROOM FIGURE 5 ECU CONTROL BOX AND MODE SWITCH	
1	PAOZZ	5998-01-486-4470	0U5N7	47013014	BOARD, ECU CONTROLLER.....	1
2	PAOZZ	6130-01-486-4462	0XM44	800-1035	POWER SUPPLY	1
3	PAOZZ	5945-01-428-2685	77342	KUMP-14018-12	RELAY	1
4	PAOZZ	5930-01-486-4740	02929	HS13-Z	SWITCH, ROTARY, 4-POSITION	1
5	PAOZZ	5355-01-486-2419	0XM44	753-2454	. KNOB.....	1
					END OF FIGURE	

**GROUP 02 MECHANICAL ROOM
AIR DISCHARGE DUCTS
REPAIR PARTS LIST**

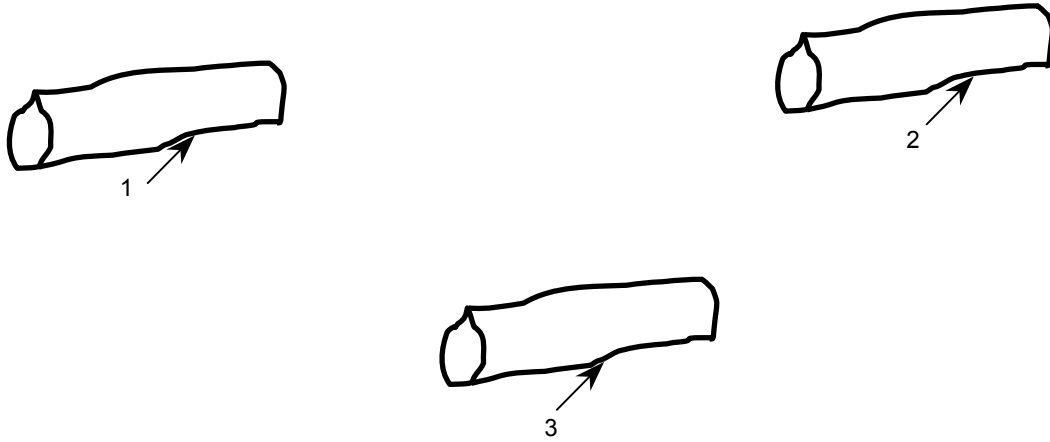

Figure 6. Air Discharge Ducts

**GROUP 02 MECHANICAL ROOM
AIR DISCHARGE DUCTS
REPAIR PARTS LIST**

(1) ITEM NO.	(2) SMR CODE	(3) NSN	(4) CAGEC	(5) PART NUMBER	(6) DESCRIPTION AND USABLE ON CODE (UOC)	(7) QTY
					GROUP 02 MECHANICAL ROOM FIGURE 6 AIR DISCHARGE DUCTS	
1	PAOZZ	4720-01-508-7406	0U5N7	47012181	AIR DISCHARGE DUCT, ECU, GREEN	1
1	PAOZZ	4720-01-515-2983	0U5N7	47012181-2TAN	AIR DISCHARGE DUCT, ECU, TAN	1
2	PAOZZ	4720-01-508-7404	0U5N7	47012180	AIR DISCHARGE DUCT, GENERATOR, GREEN	1
2	PAOZZ	4720-01-515-2998	0U5N7	47012180-2TAN	AIR DISCHARGE DUCT, GENERATOR, TAN	1
3	PAOZZ	4720-01-508-7405	0U5N7	47012190	AIR DISCHARGE DUCT, VENTHOOD, GREEN	1
3	PAOZZ	4720-01-515-2988	0U5N7	47012190-2TAN	AIR DISCHARGE DUCT, VENTHOOD, TAN	1
					END OF FIGURE	

CONTAINERIZED KITCHEN (WITH TRAILER)
GROUP 02 MECHANICAL ROOM
AIR CONDITIONER

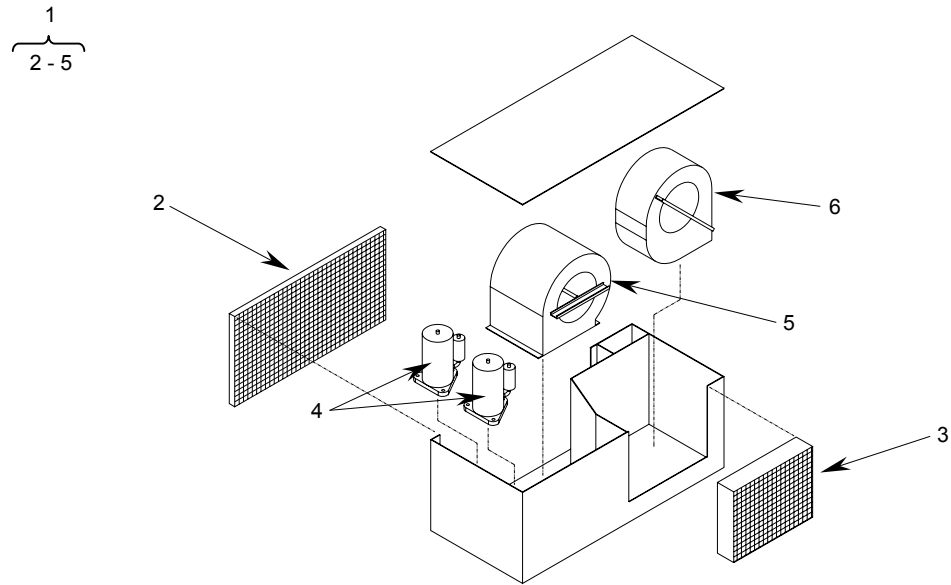

Figure 7. Air Conditioner.

**GROUP 02 MECHANICAL ROOM
AIR CONDITIONER
REPAIR PARTS LIST**

(1) ITEM NO.	(2) SMR CODE	(3) NSN	(4) CAGEC	(5) PART NUMBER	(6) DESCRIPTION AND USABLE ON CODE (UOC)	(7) QTY
					GROUP 02 MECHANICAL ROOM FIGURE 7 AIR CONDITIONER	
1	PBOFF	4120-01-486-4465	0U5N7	47011034	AIR CONDITIONER.....	2
2	XAFFF		1F3Y7	1452-1541	. COIL, CONDENSER.....	1
3	XAFFF		1F3Y7	1452-1531	. COIL, EVAPORATOR.....	1
4	XAFFF		1F3Y7	1450A2119	. COMPRESSOR.....	2
5	PBFZZ	6105-01-486-4354	1F3Y7	1468A3029	. MOTOR, BLOWER, CONDENSER.....	1
6	PBFZZ	6105-01-486-3600	1F3Y7	1468A3129	. MOTOR, BLOWER, EVAPORATOR.....	1
					END OF FIGURE	

**CONTAINERIZED KITCHEN (WITH TRAILER)
GROUP 02 MECHANICAL ROOM
INTAKE AND EXHAUST FAN INSTALLATION**

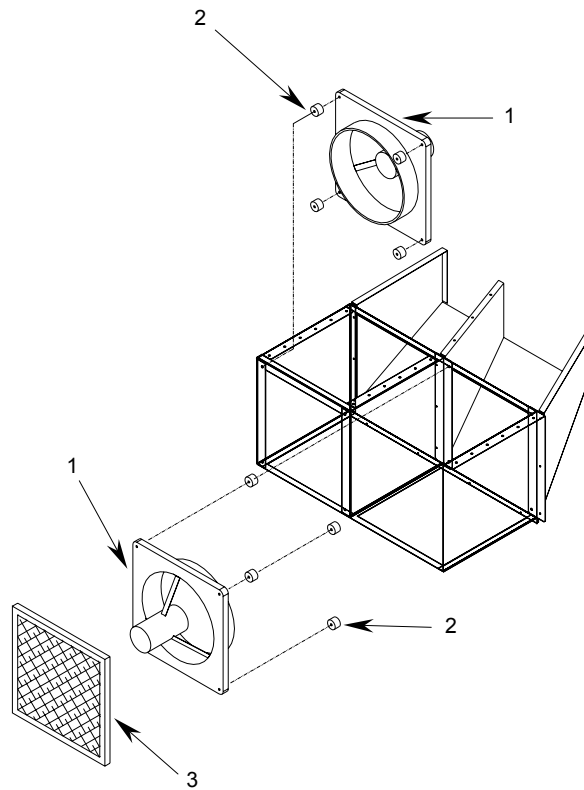

Figure 8. Intake and Exhaust Fan Installation

**GROUP 02 MECHANICAL ROOM
INTAKE AND EXHAUST FAN INSTALLATION
REPAIR PARTS LIST**

(1) ITEM NO.	(2) SMR CODE	(3) NSN	(4) CAGEC	(5) PART NUMBER	(6) DESCRIPTION AND USABLE ON CODE (UOC)	(7) QTY
					GROUP 02 MECHANICAL ROOM FIGURE 8 INTAKE AND EXHAUST FAN INSTALLATION	
1	PAOZZ	4140-01-486-2783	25795	4C865	FAN, MEDIUM PRESSURE, 14" BLADE, ALUMINUM SHROUD, 240V/60HZ.....2	
2	PAOZZ	5340-01-486-4115	2V507	9376K113	VIBRATION MOUNT, NEOPRENE.....8	
3	PAOZZ	4130-01-486-3708	39428	2150K48	FILTER, AIR INTAKE.....1	
					END OF FIGURE	

**CONTAINERIZED KITCHEN (CK)
GROUP 03 COOK CENTER REPAIR PARTS**

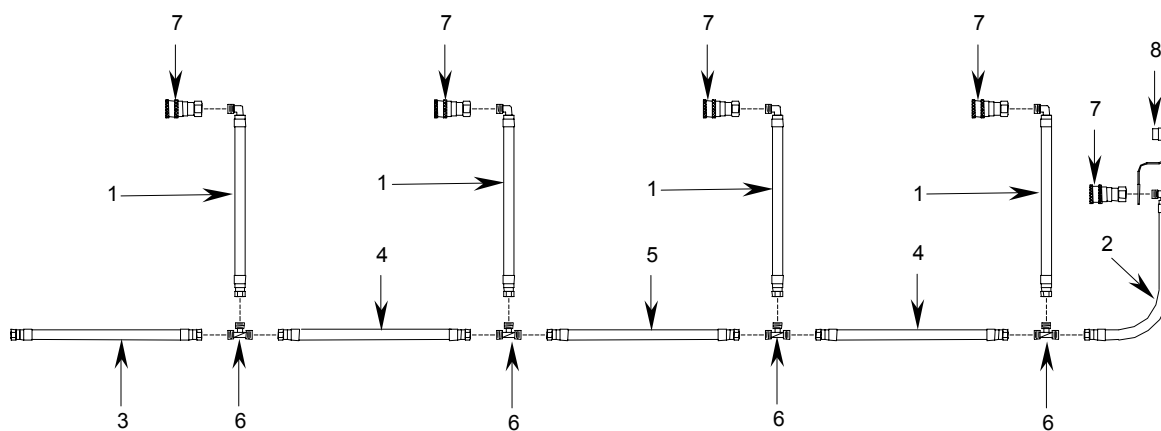

Figure 9. Fuel Line Assembly.

**CONTAINERIZED KITCHEN (CK)
GROUP 03 COOK CENTER REPAIR PARTS**

(1) ITEM NO.	(2) SMR CODE	(3) NSN	(4) CAGEC	(5) PART NUMBER	(6) DESCRIPTION AND USABLE ON CODE (UOC)	(7) QTY
GROUP 03 COOK CENTER FIGURE 9 FUEL LINE ASSEMBLY						
1	PAOZZ	4720-01-486-3785	0U5N7	47012152-1	HOSE ASSEMBLY, FUEL, MALE ELBOW TO FEMALE, 24"	4
2	PAOZZ	4720-01-486-3784	0U5N7	47012152-3	HOSE ASSEMBLY, FUEL, MALE ELBOW TO FEMALE, 66"	1
3	PAOZZ	4720-01-486-3777	0U5N7	47012153-3	HOSE ASSEMBLY, FUEL, FEMALE SWIVEL BOTH ENDS, 84"	1
4	PAOZZ	4720-01-486-3734	0U5N7	47012153-1	HOSE ASSEMBLY, FUEL, FEMALE SWIVEL BOTH ENDS, 24"	2
5	PAOZZ	4720-01-486-3727	0U5N7	47012153-4	HOSE ASSEMBLY, FUEL, FEMALE SWIVEL BOTH ENDS, 36"	1
6	PAOZZ	4730-00-092-3883	7S077	44X	TEE, UNION, BRASS	4
7	PAOZZ	4730-00-795-6959	73992	B2-H16	COUPLING, FEMALE	5
8	PAOZZ	5340-01-144-2649	7S077	P-SDC-2-HK	PLUG, DUST	1
END OF FIGURE						

**CONTAINERIZED KITCHEN (CK)
GROUP 03 COOK CENTER REPAIR PARTS**

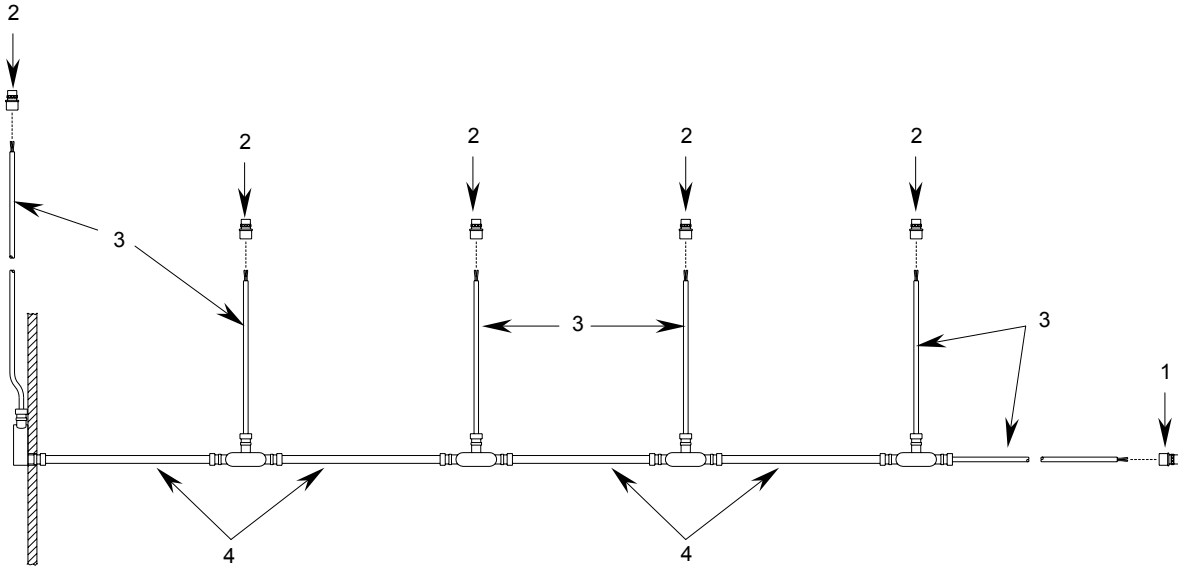

Figure 10. 24 VDC Power Cable Assembly.

**CONTAINERIZED KITCHEN (CK)
GROUP 03 COOK CENTER REPAIR PARTS**

(1) ITEM NO.	(2) SMR CODE	(3) NSN	(4) CAGEC	(5) PART NUMBER	(6) DESCRIPTION AND USABLE ON CODE (UOC)	(7) QTY
GROUP 03 COOK CENTER						
FIGURE 10 24VDC POWER CABLE ASSEMBLY						
1	PAOZZ	5935-01-116-3615	96906	MS3106F16-11P	CONNECTOR, PLUG, MALE, 2-PIN.....	1
2	PAOZZ	5935-00-321-8295	96906	MS3106F16-11S	CONNECTOR, PLUG, FEMALE, 2-PIN	5
3	MOOZZ		0U5N7	47013007	CABLE, MAKE FROM CAGE 097M6, PN 85022	V
4	MOOZZ		0U5N7	47013007	CABLE, MAKE FROM CAGE 097M6, PN RM-WIRE12RED AND PN RM-WIRE12BLK.....	V
END OF FIGURE						

**CONTAINERIZED KITCHEN (WITH TRAILER)
GROUP 05 OVEN ASSEMBLY**

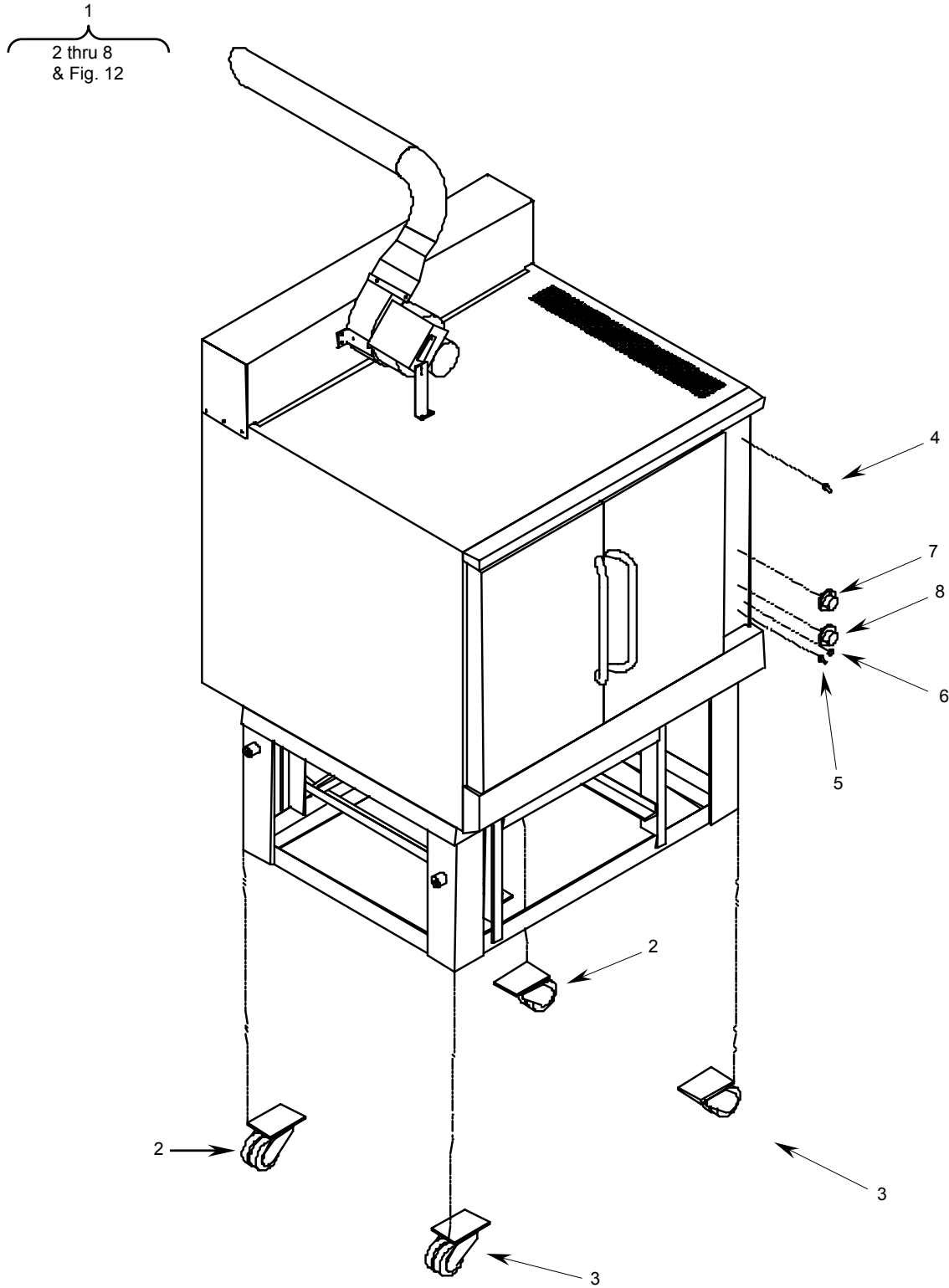

Figure 11. Oven Assembly.

**GROUP 05 OVEN ASSEMBLY
REPAIR PARTS LIST**

(1) ITEM NO.	(2) SMR CODE	(3) NSN	(4) CAGEC	(5) PART NUMBER	(6) DESCRIPTION AND USABLE ON CODE (UOC)	(7) QTY
					GROUP 05 OVEN ASSEMBLY	
					FIGURE 11 OVEN ASSEMBLY	
1	PAOFF	7310-01-486-4360	0U5N7	47011084	OVEN ASSEMBLY, SINGLE	1
2	PBOZZ	5340-01-493-9359	86420	060-3PJ-DW	CASTER, SWIVEL.....	2
3	PBOZZ	5340-01-493-9348	86420	060-3PJ-DW-WK	CASTER, SWIVEL, WITH BRAKE	2
4	PAOZZ	5930-01-486-4747	097M6	HBL11SP	SWITCH, TOGGLE, SPST	1
5	PAOZZ	5930-01-289-4219	75582	5744	SWITCH, TOGGLE, DPDT	1
6	PAOZZ	4940-01-125-1755	3V171	5SF2LRN2	LIGHT, INDICATOR.....	1
7	XDOZZ		38379	98-1480	TIMER, 60 MINUTE	1
8	PAOZZ	6645-01-238-8659	38379	10-5553	TIMER, 5 HOUR	1
					END OF FIGURE	

CONTAINERIZED KITCHEN (WITH TRAILER)
GROUP 05 OVEN ASSEMBLY
OVEN FAN ASSEMBLY

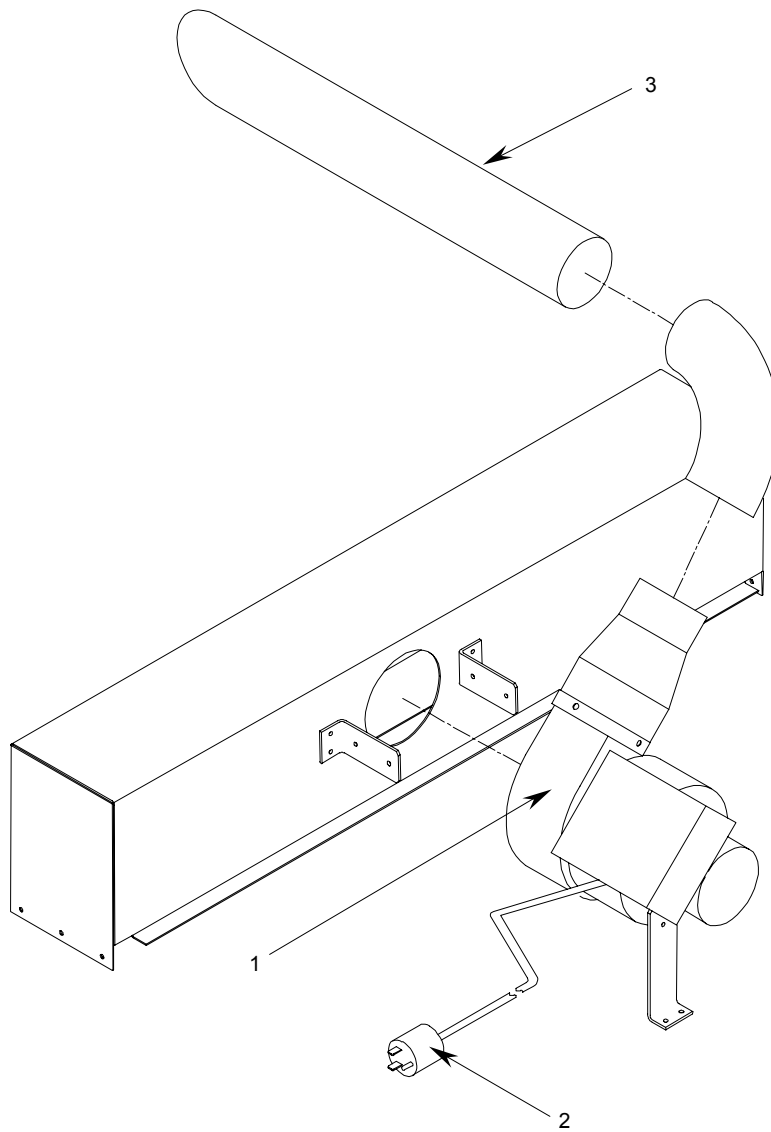

Figure 12. Oven Fan Assembly.

**GROUP 05 OVEN ASSEMBLY
OVEN FAN ASSEMBLY
REPAIR PARTS LIST**

(1) ITEM NO.	(2) SMR CODE	(3) NSN	(4) CAGEC	(5) PART NUMBER	(6) DESCRIPTION AND USABLE ON CODE (UOC)	(7) QTY
					GROUP 05 OVEN ASSEMBLY	
					FIGURE 12 OVEN FAN ASSEMBLY	
1	PAOZZ	4140-01-486-4727	25795	4C727	BLOWER	1
2	PAOZZ	5930-01-486-4756	097M6	7594V	PLUG, TWIST-LOC	1
3	PAOZZ	4520-01-508-5410	0U5N7	47012266	PIPE, AIR CONDITIONING HEATING	1
					END OF FIGURE	

CONTAINERIZED KITCHEN (WITH TRAILER)
GROUP 05 OVEN ASSEMBLY
FUEL LINE ASSEMBLY

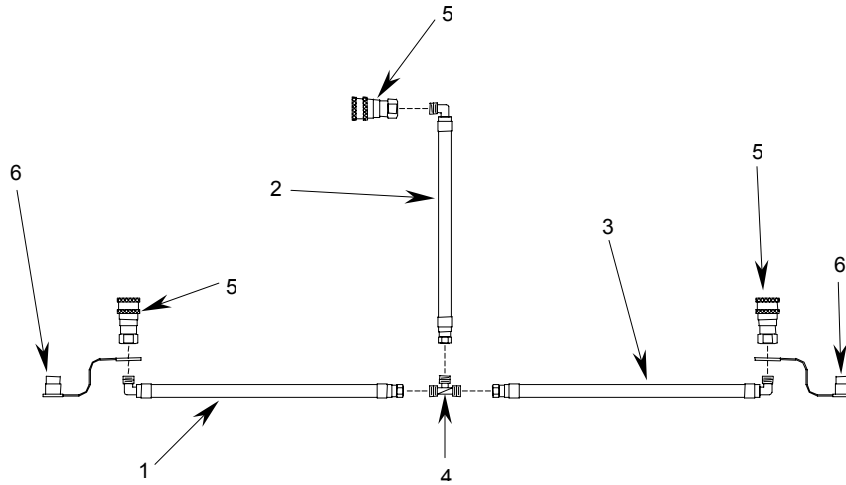

Figure 13. Fuel Line Assembly.

**GROUP 05 OVEN ASSEMBLY
FUEL LINE ASSEMBLY
REPAIR PARTS LIST**

(1) ITEM NO.	(2) SMR CODE	(3) NSN	(4) CAGEC	(5) PART NUMBER	(6) DESCRIPTION AND USABLE ON CODE (UOC)	(7) QTY
					GROUP 05 OVEN ASSEMBLY FIGURE 13 FUEL LINE ASSEMBLY	
1	PAOZZ	4720-01-486-1981	0U5N7	47012152-5	HOSE ASSEMBLY, FUEL, MALE ELBOW TO FEMALE, 114"	1
2	PAOZZ	4720-01-486-4606	0U5N7	47012152-2	HOSE ASSEMBLY, FUEL, MALE ELBOW TO FEMALE, 36"	1
3	PAOZZ	4720-01-486-4418	0U5N7	47012152-4	HOSE ASSEMBLY, FUEL, MALE ELBOW TO FEMALE, 84"	1
4	PAOZZ	4730-00-092-3883	7S077	44X	TEE, UNION, BRASS	1
5	PAOZZ	4730-00-795-6959	73992	B2-H16	COUPLING, FEMALE	3
6	PAOZZ	5340-01-144-2649	7S077	P-SDC-2-HK	PLUG, DUST	2
					END OF FIGURE	

CONTAINERIZED KITCHEN (WITH TRAILER)
GROUP 05 OVEN ASSEMBLY
24 VDC POWER CABLE ASSEMBLY

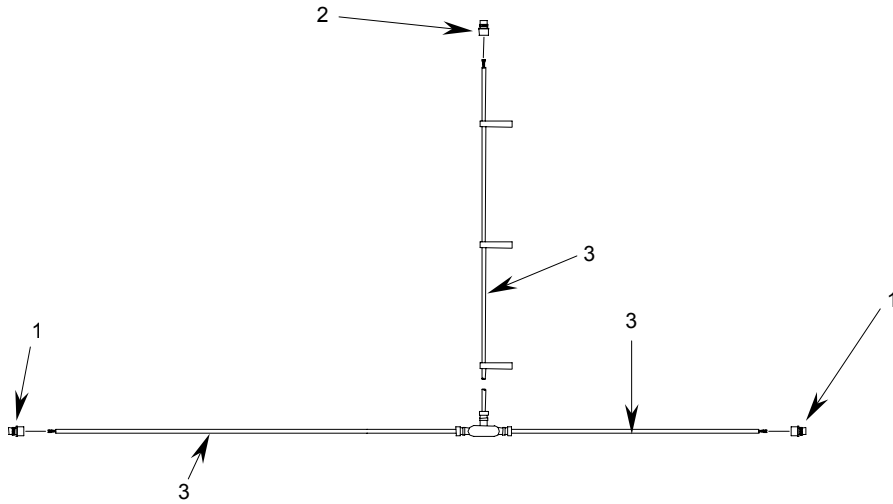

Figure 14. 24 VDC Power Cable Assembly.

**GROUP 05 OVEN ASSEMBLY
24 VDC POWER CABLE ASSEMBLY
REPAIR PARTS LIST**

(1) ITEM NO.	(2) SMR CODE	(3) NSN	(4) CAGEC	(5) PART NUMBER	(6) DESCRIPTION AND USABLE ON CODE (UOC)	(7) QTY
					GROUP 05 OVEN ASSEMBLY FIGURE 14 24 VDC POWER CABLE ASSEMBLY	
1	PAOZZ	5935-00-321-8295	96906	MS3106F16-11S	CONNECTOR, PLUG, FEMALE, 2-PIN2	
2	PAOZZ	5935-01-116-3615	96906	MS3106F16-11P	CONNECTOR, PLUG, MALE, 2-PIN.....1	
3	MOOZZ		0U5N7	47013009	CABLE, MAKE FROM CAGE 097M6, PN 85022 V	
					END OF FIGURE	

**CONTAINERIZED KITCHEN (WITH TRAILER)
GROUP 06 MOBILE WARMING CABINET**

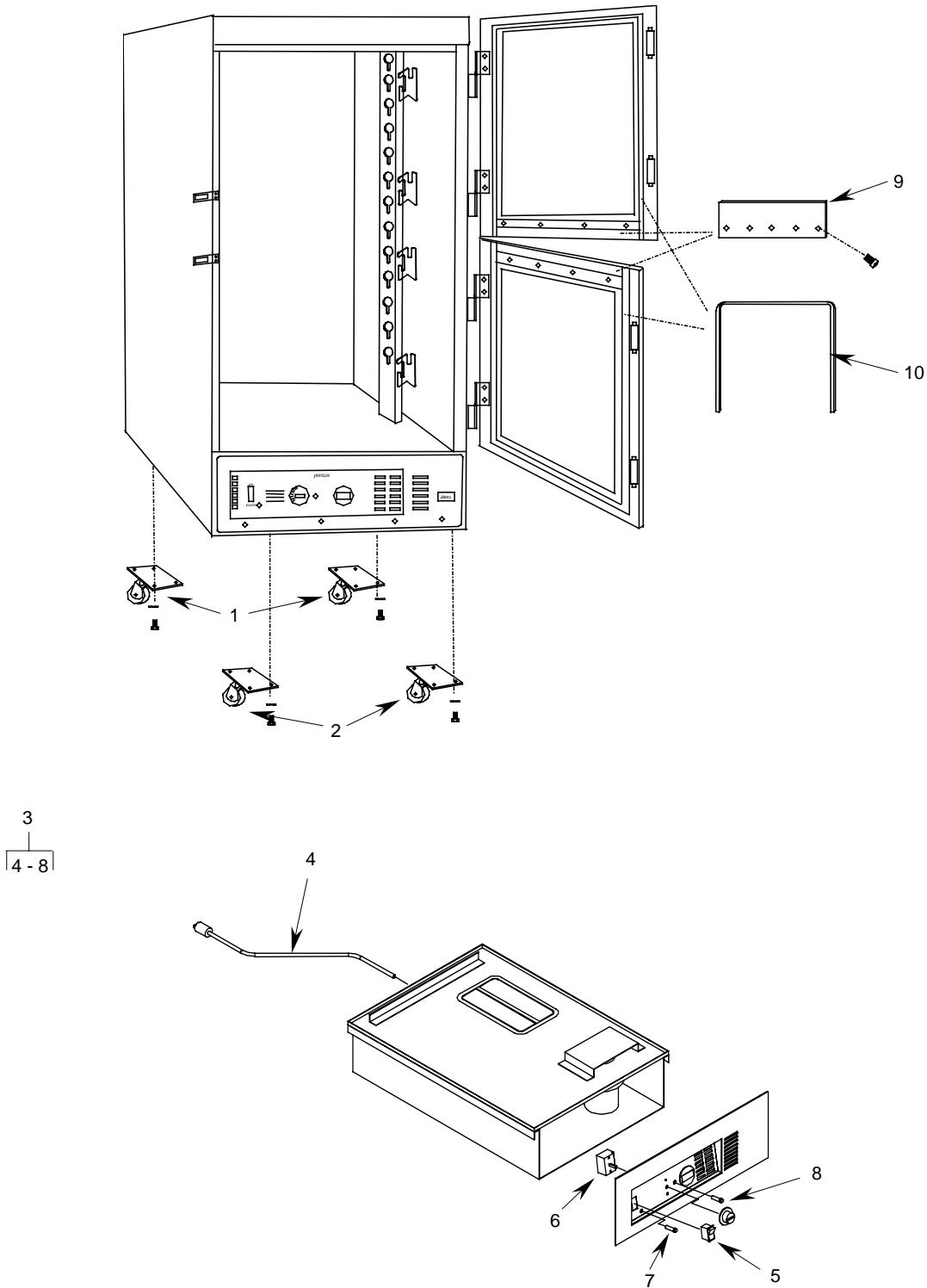

Figure 15. Mobile Warming Cabinet.

**GROUP 06 MOBILE WARMING CABINET
REPAIR PARTS LIST**

(1) ITEM NO.	(2) SMR CODE	(3) NSN	(4) CAGEC	(5) PART NUMBER	(6) DESCRIPTION AND USABLE ON CODE (UOC)	(7) QTY
					GROUP 06 MOBILE WARMING CABINET FIGURE 15 MOBILE WARMING CABINET	
1	PBOZZ	5340-01-486-1832	40038	RPB5D	CASTER, SWIVEL	2
2	PBOZZ	5340-01-486-1916	40038	RPB5NB	CASTER, SWIVEL, WITH BRAKE	2
3	PBOZZ	7360-01-486-8328	40038	RP-HM2000	MODULE, HOLDING.....	1
4	PAOZZ	6150-01-486-4603	0U5N7	47013012	. ASSEMBLY, POWER CORD	1
5	PAOZZ	5930-01-486-4250	40038	RPC13-127	. SWITCH, POWER.....	1
6	PAOZZ	6685-01-486-3679	40038	RPC13-129	. THERMOSTAT	1
7	PAOZZ	6210-01-486-1826	40038	RPC13-105	. LIGHT, INDICATOR, YELLOW	1
8	PAOZZ	6210-01-486-1824	40038	RPC13-064	. LIGHT, INDICATOR, RED.....	1
9	PBOZZ	5330-01-486-2447	40038	RPC07-032- 23.250	SEAL, DOOR	2
10	PBOZZ	5330-01-486-3183	40038	RPC06-317	GASKET, DOOR.....	2
					END OF FIGURE	

**CONTAINERIZED KITCHEN (WITH TRAILER)
GROUP 07 REFRIGERATOR**

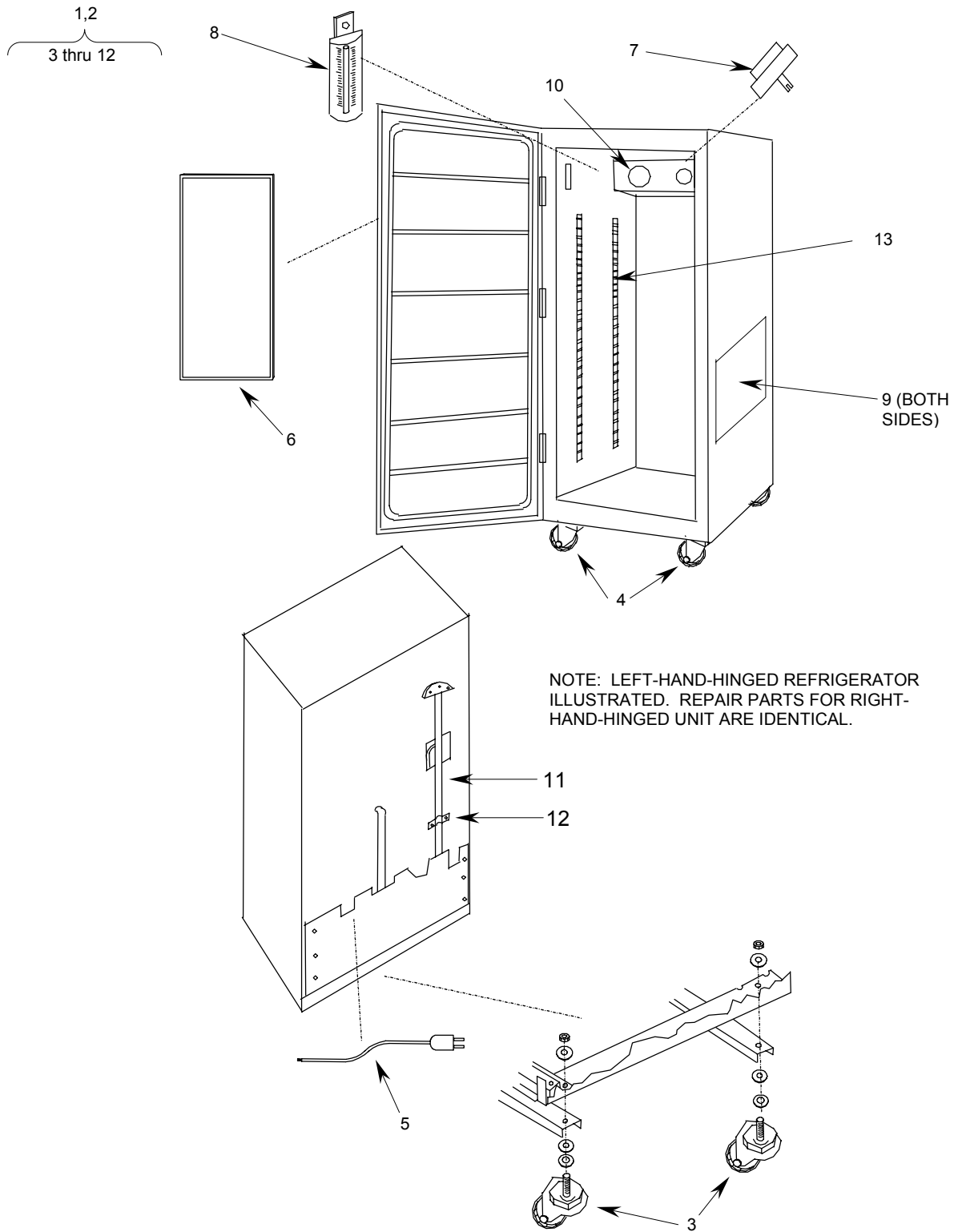

Figure 16. Refrigerator.

**GROUP 07 REFRIGERATOR
REPAIR PARTS LIST**

(1) ITEM NO.	(2) SMR CODE	(3) NSN	(4) CAGEC	(5) PART NUMBER	(6) DESCRIPTION AND USABLE ON CODE (UOC)	(7) QTY
GROUP 07 REFRIGERATORS						
FIGURE 16 REFRIGERATOR						
1	PAOOO	4110-01-486-4390	0U5N7	47011031	REFRIGERATOR, LEFT HAND	1
2	PAOOO	4110-01-486-4388	0U5N7	47011026	REFRIGERATOR, RIGHT HAND	1
3	PAOZZ	5340-01-486-1825	9R633	18202-002	CASTER, SWIVEL	2
4	PA OZZ	5340-01-486-2455	9R633	18202-001	CASTER, SWIVEL, WITH BRAKE	2
5	PAOZZ	6150-01-486-4603	0U5N7	47013012	ASSEMBLY, POWER CORD	1
6	PBOZZ	5330-01-486-1410	9R633	17963-000	GASKET, DOOR.....	1
7	PAOZZ	6685-01-486-4748	9R633	16830-000	TEMPERATURE CONTROL	1
8	PBOZZ	6685-01-486-4758	9R633	17465-000	THERMOMETER.....	1
9	PAOZZ	9330-01-486-5500	39428	8689K31	FILM, POLYESTER, CLEAR, 2 MIL, ADHESIVE-BACKED	2
10	PAOZZ	6240-00-944-8202	9R633	14597-000	LAMP, INCANDESCENT	1
11	PAOZZ		9R633	8921-045	HOSE, CONDENSATE DRAIN.....	1
12	PAOZZ		9R633	6246-000	CLIP, RETAINER.....	1
13	PAOZZ		9R633	8468-301	CLIP, SHELF	12
END OF FIGURE						

**CONTAINERIZED KITCHEN (WITH TRAILER)
GROUP 08 TRAY PACK HEATER**

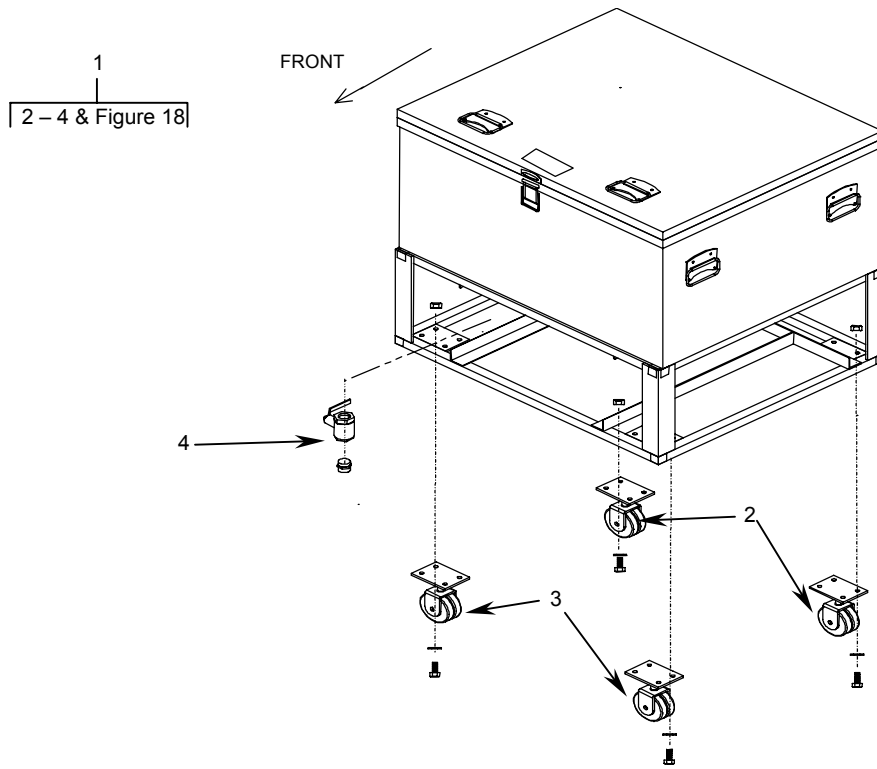

Figure 17. Tray Pack Heater

**GROUP 08 TRAY PACK HEATER
TRAY PACK HEATER
REPAIR PARTS LIST**

(1) ITEM NO.	(2) SMR CODE	(3) NSN	(4) CAGEC	(5) PART NUMBER	(6) DESCRIPTION AND USABLE ON CODE (UOC)	(7) QTY
					GROUP 08 TRAY PACK HEATER FIGURE 17 TRAY PACK HEATER	
1	PAOOO	7310-01-486-4353	0USN7	47011062	HEATER, TRAY PACK.....	1
2	PBOZZ	5340-01-486-2450	39428	9908T18	CASTER, SWIVEL.....	2
3	PBOZZ	5340-01-486-2490	39428	9908T31	CASTER, SWIVEL, WITH BRAKE	2
4	PAOZZ	4820-01-486-3823	79227	B6002	VALVE, DRAIN	1
					END OF FIGURE	

CONTAINERIZED KITCHEN (WITH TRAILER)
GROUP 08 TRAY PACK HEATER
HEATER FAN ASSEMBLY

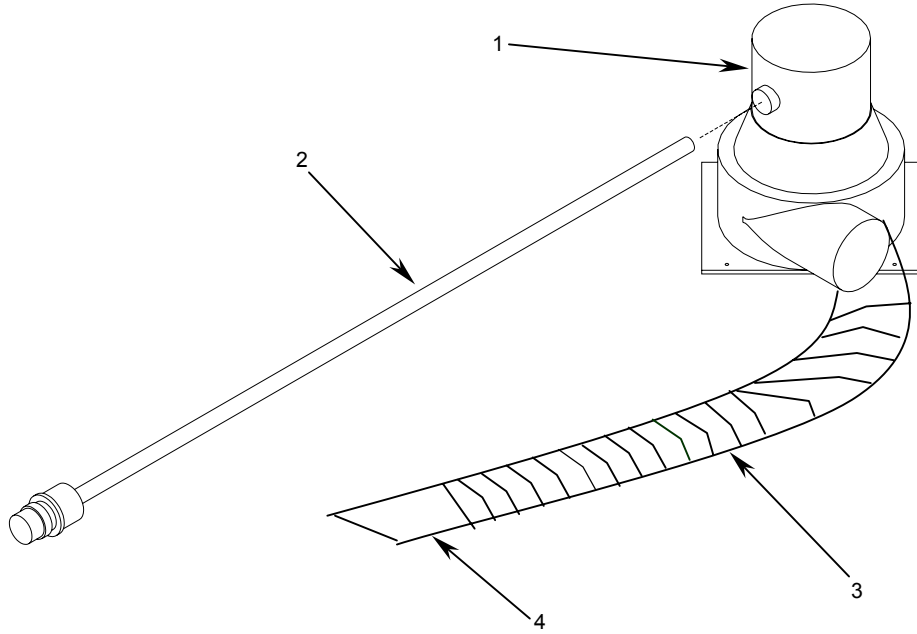

Figure 18. Heater Fan Assembly.

**GROUP 08 TRAY PACK HEATER
HEATER FAN ASSEMBLY
REPAIR PARTS LIST**

(1) ITEM NO.	(2) SMR CODE	(3) NSN	(4) CAGEC	(5) PART NUMBER	(6) DESCRIPTION AND USABLE ON CODE (UOC)	(7) QTY
					GROUP 08 TRAY PACK HEATER	
					FIGURE 18 HEATER FAN ASSEMBLY	
1	PAOZZ	4140-01-486-3873	0LD16	A128	BLOWER	1
2	PAOZZ	6150-01-486-3711	097M6	40905	ASSEMBLY, POWER CABLE	1
3	PAOZZ	4720-01-519-8206	39428	5262K29	FLEXIBLE HOSE	1
4	PAOZZ	4710-01-519-2748	39428	47012399-1	TUBE, EXHAUST EXTENSION (Green)	1
4	PAOZZ	4710-01-519-2747	39428	47012399-2	TUBE, EXHAUST EXTENSION (Tan)	1
					END OF FIGURE	

**CONTAINERIZED KITCHEN (WITH TRAILER)
GROUP 09 HAND SINK ASSEMBLY**

1
2 thru 9

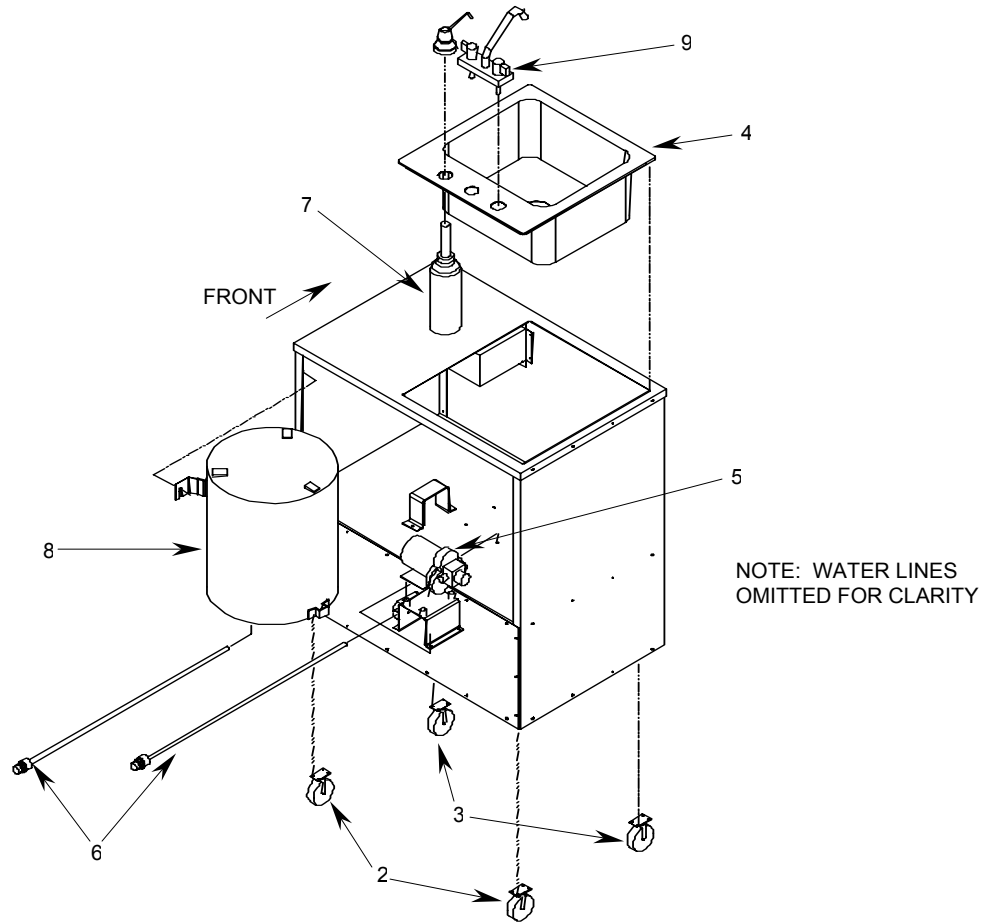

10
11

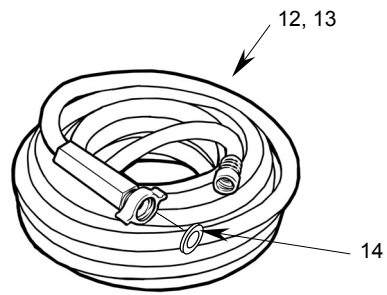
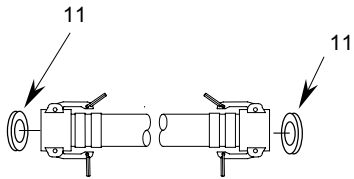

Figure 19. Hand Sink Assembly.

**GROUP 09 HAND SINK ASSEMBLY
REPAIR PARTS LIST**

(1) ITEM NO.	(2) SMR CODE	(3) NSN	(4) CAGEC	(5) PART NUMBER	(6) DESCRIPTION AND USABLE ON CODE (UOC)	(7) QTY
					GROUP 09 HAND SINK ASSEMBLY	
					FIGURE 19 HAND SINK ASSEMBLY	
1	PAOOO	4540-01-486-4399	0U5N7	47011028	SINK ASSEMBLY, HAND	1
2	PBOZZ	5340-01-486-2436	39428	22785T63	CASTER, SWIVEL	2
3	PBOZZ	5340-01-486-2469	39428	22785T68	CASTER, SWIVEL, WITH BRAKE	2
4	XDOZZ		80298	23605K52	SINK, HAND	1
5	PAOZZ	4320-01-486-3601	09BX1	2088-594-154	PUMP, WATER.....	1
6	PAOZZ	6150-01-486-3711	097M6	40905	ASSEMBLY, POWER CABLE	2
7	PAOZZ	4510-01-465-5541	39428	2773K1	DISPENSER, SOAP	1
8	PAOZZ	4520-01-486-3781	86458	M-I-WH6U3SS	HEATER, WATER	1
9	PAOZZ	4510-01-486-3718	20247	LK-2490-BH	FAUCET, LAUNDRY, HOSE THREADED	1
10	PAOZZ	4720-01-486-4464	0U5N7	47011050-2	HOSE ASSEMBLY, INTERNAL DRAIN	1
11	PAOZZ	5330-01-486-2809	7S077	B03	. GASKET, BUNA N.....	2
12	PAOZZ	4720-01-482-0367	39428	6226T12	HOSE, WATER SUPPLY, 50-FT	1
13	PAOZZ	4720-01-486-4309	39428	6226T11	HOSE, WATER SUPPLY, 25-FT	2
14	PAOZZ	5310-01-483-6326	39428	66215T78	. WASHER, HOSE	6
					END OF FIGURE	

**CONTAINERIZED KITCHEN (WITH TRAILER)
GROUP 10 MOBILE STORAGE CABINET**

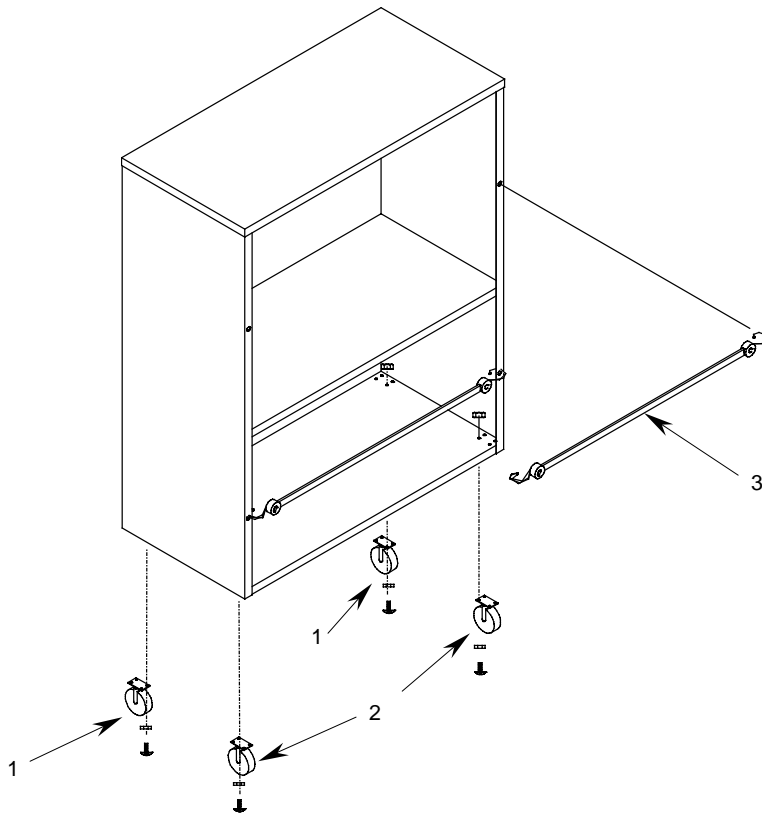

Figure 20. Mobile Storage Cabinet.

**GROUP 10 MOBILE STORAGE CABINET
REPAIR PARTS LIST**

(1) ITEM NO.	(2) SMR CODE	(3) NSN	(4) CAGEC	(5) PART NUMBER	(6) DESCRIPTION AND USABLE ON CODE (UOC)	(7) QTY
					GROUP 10 MOBILE STORAGE CABINETS FIGURE 20 MOBILE STORAGE CABINET	
1	PBOZZ	5340-01-486-2436	39428	22785T63	CASTER, SWIVEL	2
2	PBOZZ	5340-01-486-2469	39428	22785T68	CASTER, SWIVEL, WITH BRAKE	2
3	PAOZZ	2030-01-168-9371	39428	3891T16	TIE-DOWN, MOLDED RUBBER, 28"	2
					END OF FIGURE	

CONTAINERIZED KITCHEN (WITH TRAILER)
GROUP 11 PREP/SERVING TABLE

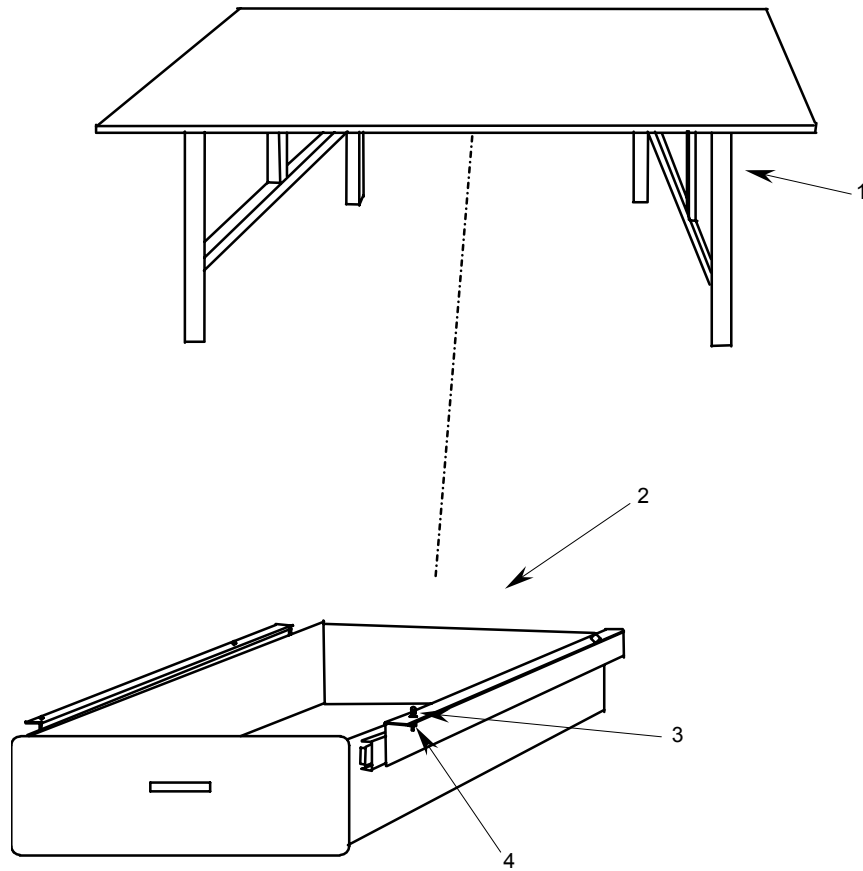

Figure 21. Prep/Serving Table.

**GROUP 11 PREP/SERVING TABLE
REPAIR PARTS LIST**

(1) ITEM NO.	(2) SMR CODE	(3) NSN	(4) CAGEC	(5) PART NUMBER	(6) DESCRIPTION AND USABLE ON CODE (UOC)	(7) QTY
					GROUP 11 PREP/SERVING TABLES	
					FIGURE 21 PREP/SERVING TABLE	
1	PBOZZ	7105-01-486-5929	0U5N7	47016030	TABLE, FOLDING LEGS	1
2	PBOZZ	7195-01-486-5461	0U5N7	47011047	ASSEMBLY, TABLE DRAWER	1
3	PBOZZ		51506	C18080-S-31	THUMB SCREW	4
4	PBOZZ		51506	10614-S-31	SPLIT WASHER	4
					END OF FIGURE	

**CONTAINERIZED KITCHEN (WITH TRAILER)
GROUP 12 ELECTRICAL SYSTEM
POWER ENTRANCE PANEL**

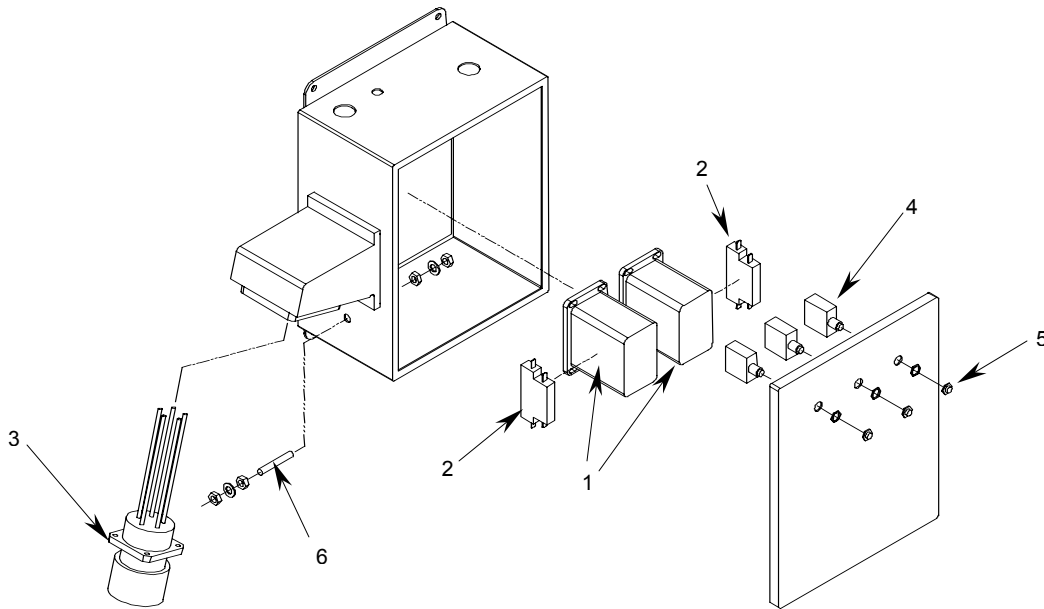

Figure 22. Power Entrance Panel.

**GROUP 12 ELECTRICAL SYSTEM
POWER ENTRANCE PANEL
REPAIR PARTS LIST**

(1) ITEM NO.	(2) SMR CODE	(3) NSN	(4) CAGEC	(5) PART NUMBER	(6) DESCRIPTION AND USABLE ON CODE (UOC)	(7) QTY
GROUP 12 ELECTRICAL SYSTEM FIGURE 22 POWER ENTRANCE PANEL						
1	PAOZZ	6110-01-486-3904	097M6	DPA63-VO2	CONTACTOR, 3-POLE, 60 AMP.....	2
2	PAOZZ	6110-01-486-4604	097M6	DPA-D11	CONTACTOR, AUXILIARY	2
3	PAOZZ	5999-01-486-4304	0U5N7	47013023	ASSEMBLY, RECEPTACLE, EXTERNAL POWER	1
4	PAOZZ	5925-01-486-4721	097M6	W58-XB4A4A-5	CIRCUIT BREAKER, 5 AMP	3
5	PAOZZ	5930-00-832-3269	097M6	N3030B	BOOT, PUSHBUTTON	3
6	PAOZZ	5305-01-486-2475	0U5N7	47012381	TERMINAL, GROUND	1
(Cut to length)						
END OF FIGURE						

**CONTAINERIZED KITCHEN (WITH TRAILER)
GROUP 12 ELECTRICAL SYSTEM
POWER DISTRIBUTION PANEL**

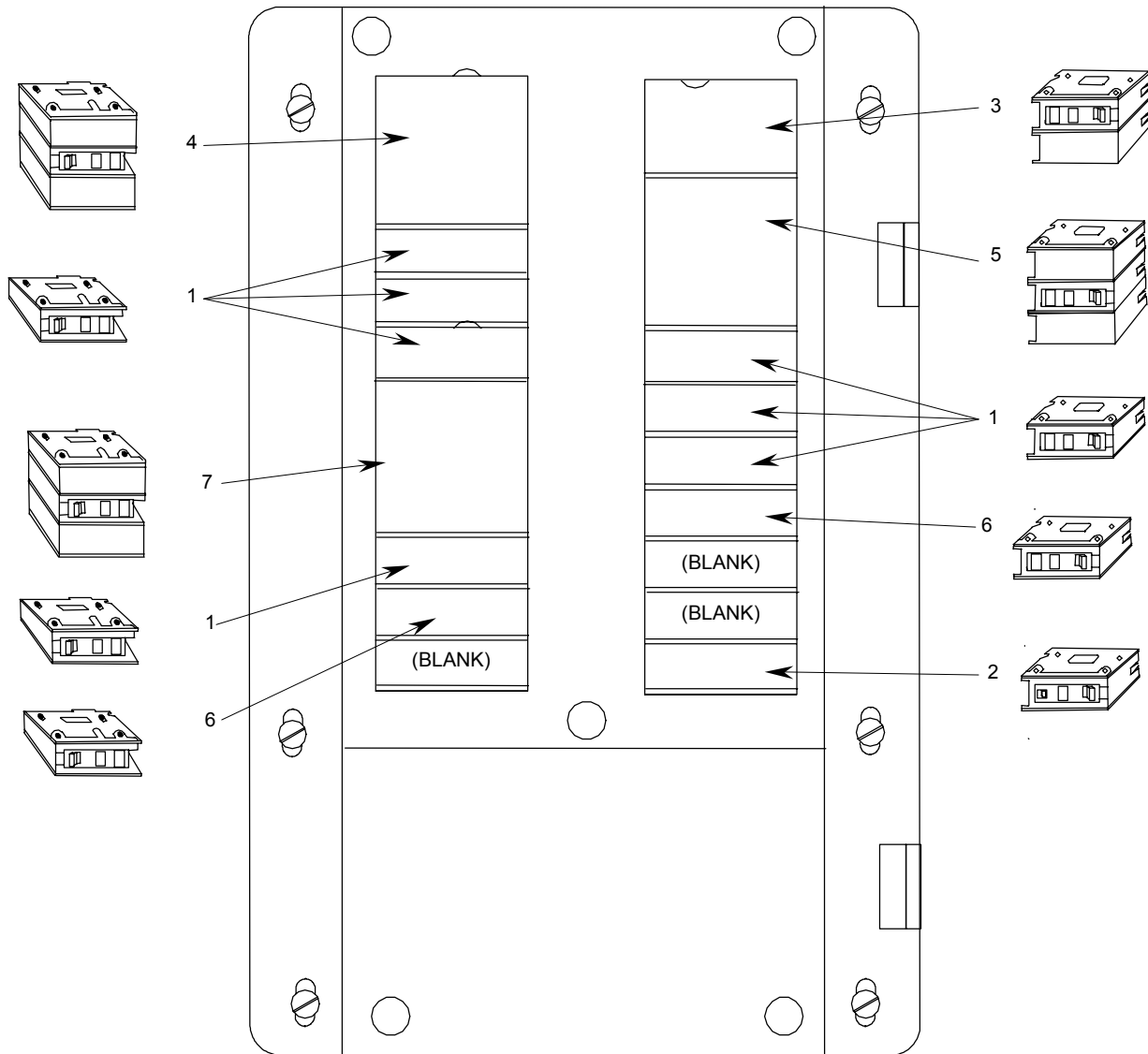

Figure 23. Power Distribution Panel.

**GROUP 12 ELECTRICAL SYSTEM
POWER DISTRIBUTION PANEL
REPAIR PARTS LIST**

(1) ITEM NO.	(2) SMR CODE	(3) NSN	(4) CAGEC	(5) PART NUMBER	(6) DESCRIPTION AND USABLE ON CODE (UOC)	(7) QTY
GROUP 12 ELECTRICAL SYSTEM FIGURE 23 POWER DISTRIBUTION PANEL						
1	PAOZZ	5925-00-984-2163	56303	QOB115	CIRCUIT BREAKER, 1 POLE, 15 A	7
2	PAOZZ	5925-01-018-3041	56303	QOB115GFI	CIRCUIT BREAKER, 1 POLE, 15 A, GFI	1
3	PAOZZ	5925-01-245-6479	56303	QOB210	CIRCUIT BREAKER, 2 POLE 10 A	1
4	PAOZZ	5925-00-936-3933	56303	QOB360	CIRCUIT BREAKER, 3 POLE, 60 A	1
5	PAOZZ	5925-00-983-5666	56303	QOB315	CIRCUIT BREAKER, 3 POLE, 15 A	1
6	PAOZZ	5925-01-056-5127	56303	QOB110	CIRCUIT BREAKER, 1 POLE, 10 A	2
7	PAOZZ	5925-00-728-1969	56365	QOB330	CIRCUIT BREAKER, 3 POLE, 30 A	1
END OF FIGURE						

CONTAINERIZED KITCHEN (WITH TRAILER)
GROUP 12 ELECTRICAL SYSTEM
MAIN CONTROL PANEL

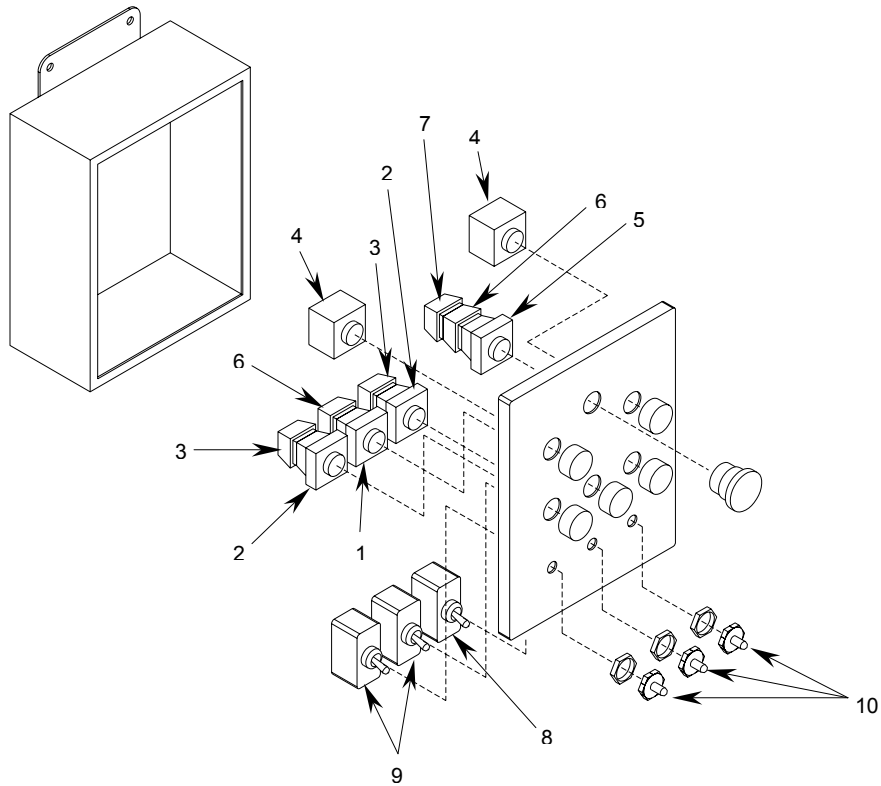

Figure 24. Main Control Panel.

**GROUP 12 ELECTRICAL SYSTEM
MAIN CONTROL PANEL
REPAIR PARTS LIST**

(1) ITEM NO.	(2) SMR CODE	(3) NSN	(4) CAGEC	(5) PART NUMBER	(6) DESCRIPTION AND USABLE ON CODE (UOC)	(7) QTY
					GROUP 12 ELECTRICAL SYSTEM FIGURE 24 MAIN CONTROL PANEL	
1	PAOZZ	5930-01-302-9739	0ET52	ZB2BA2	PUSH BUTTON, MOMENTARY.....	1
2	PAOZZ	5930-01-367-5513	52090	ZB2BW33	PUSH BUTTON, ILLUMINATED, GREEN.....	2
3	PAOZZ	5930-01-291-5467	52090	ZB2BW061	CONTACT BLOCK, LIGHT MODULE	2
4	PAOZZ	6210-01-172-5978	37833	ZB2BV05	LIGHT, PILOT, AMBER	2
5	PAOZZ	5930-01-306-9740	37833	ZB2BT4	PUSH BUTTON, RED, 40 MM, MAINTAINED	1
6	PAOZZ	5930-01-174-8604	37833	ZB2BZ104	CONTACT BLOCK, 2 N.C. CIRCUITS	2
7	PAOZZ	5930-01-289-0884	52090	ZB2BZ102	CONTACT BLOCK, 1 N.C. CIRCUIT.....	1
8	PAOZZ	5930-01-486-4714	097M6	HBL22SP	SWITCH, TOGGLE, DPDT, SPADE TERMINAL.....	1
9	PAOZZ	5930-01-486-4747	097M6	HBL11SP	SWITCH, TOGGLE, SPST, SPADE TERMINAL	2
10	PAOZZ	5930-01-486-4755	097M6	SSB1	BOOT, SWITCH.....	3
					END OF FIGURE	

CONTAINERIZED KITCHEN (WITH TRAILER)
GROUP 12 ELECTRICAL SYSTEM
APPLIANCE CONTROL BOX

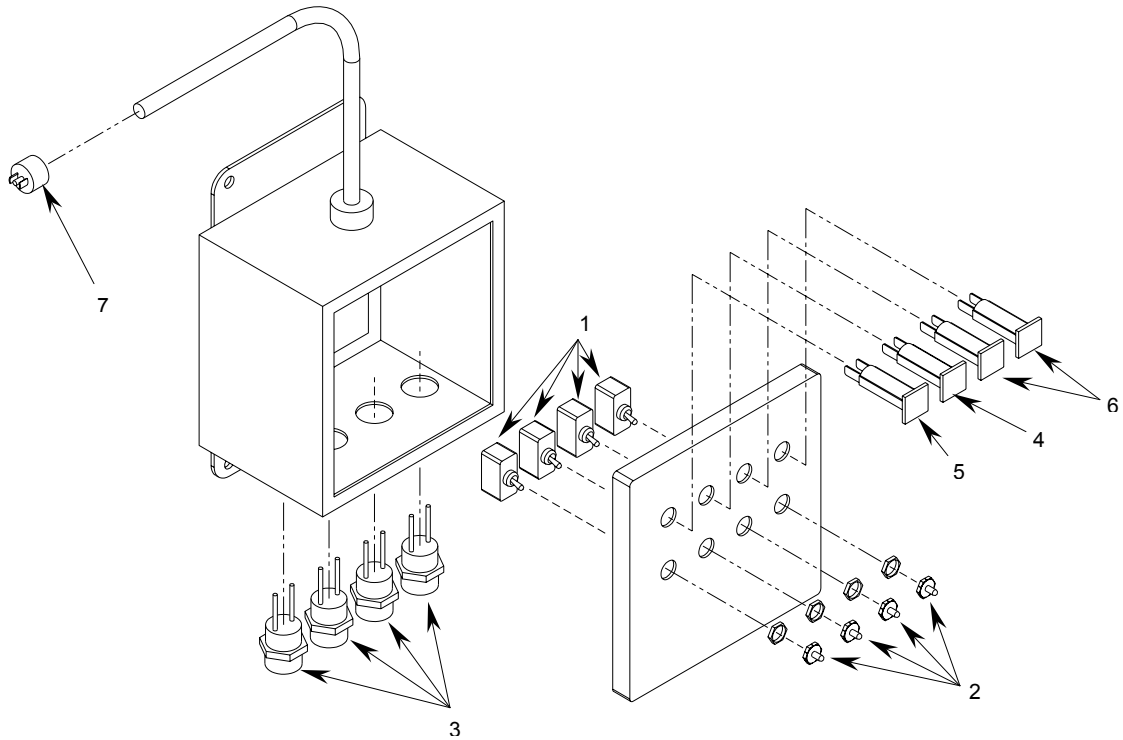

Figure 25. Appliance Control Box.

**GROUP 12 ELECTRICAL SYSTEM
 APPLIANCE CONTROL BOX
 REPAIR PARTS LIST**

(1) ITEM NO.	(2) SMR CODE	(3) NSN	(4) CAGEC	(5) PART NUMBER	(6) DESCRIPTION AND USABLE ON CODE (UOC)	(7) QTY
					GROUP 12 ELECTRICAL SYSTEM FIGURE 25 APPLIANCE CONTROL BOX	
1	PAOZZ	5930-01-486-4747	097M6	HBL11SP	SWITCH, TOGGLE, SPST, SPADE TERMINAL.....	4
2	PAOZZ	5930-01-486-4755	097M6	SSB1	BOOT, SWITCH.....	4
3	PAOZZ	5935-01-486-4703	097M6	40910	RECEPTACLE, MINI-CHANGE, 3-POLE.....	4
4	PAOZZ	5925-01-280-0280	77342	W28XQ1A-2	CIRCUIT BREAKER, 2 A.....	1
5	PAOZZ	5925-01-486-3911	097M6	W28XQ1A-6	CIRCUIT BREAKER, 6 A.....	1
6	PAOZZ	5925-01-299-1282	77342	W28XQ1A-1	CIRCUIT BREAKER, 1 A.....	2
7	PAOZZ	5935-01-486-4756	097M6	7594V	PLUG, TWIST-LOC, 15 A IDC.....	1
					END OF FIGURE	

CONTAINERIZED KITCHEN (WITH TRAILER)
GROUP 12 ELECTRICAL SYSTEM
MBU POWER SWITCH ASSEMBLY

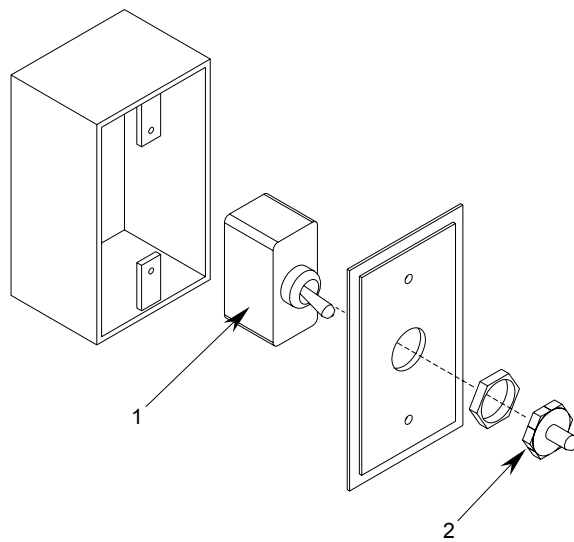

Figure 26. MBU Power Switch Assembly.

**GROUP 12 ELECTRICAL SYSTEM
 MBU POWER SWITCH ASSEMBLY
 REPAIR PARTS LIST**

(1) ITEM NO.	(2) SMR CODE	(3) NSN	(4) CAGEC	(5) PART NUMBER	(6) DESCRIPTION AND USABLE ON CODE (UOC)	(7) QTY
					GROUP 12 ELECTRICAL SYSTEM FIGURE 26 MBU POWER SWITCH ASSEMBLY	
1	PAOZZ	5930-01-486-4747	097M6	HBL11SP	SWITCH, TOGGLE, SPST, SPADE TERMINAL.....	1
2	PAOZZ	5930-01-486-4755	097M6	SSB1	BOOT, SWITCH.....	1
					END OF FIGURE	

**CONTAINERIZED KITCHEN (WITH TRAILER)
GROUP 12 ELECTRICAL SYSTEM
CEILING LIGHT - FIXED**

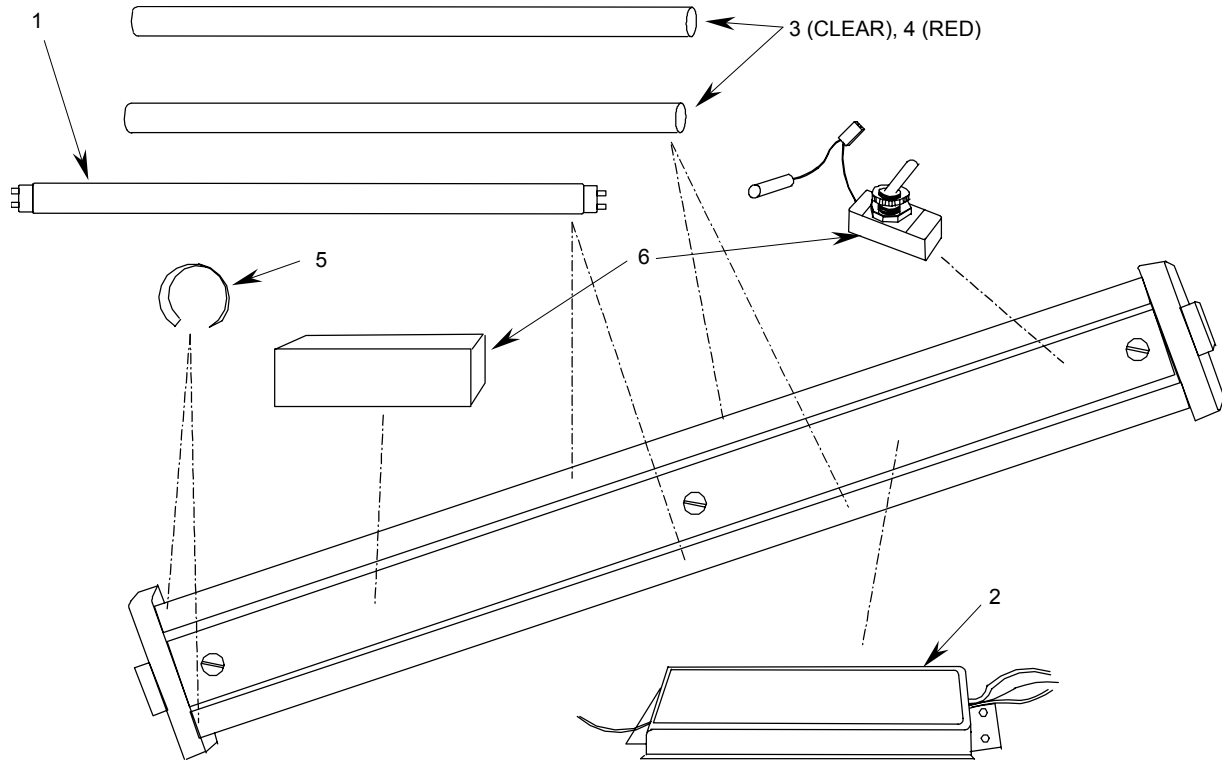

Figure 27. Ceiling Light – Fixed.

**GROUP 12 ELECTRICAL SYSTEM
CEILING LIGHT - FIXED
REPAIR PARTS LIST**

(1) ITEM NO.	(2) SMR CODE	(3) NSN	(4) CAGEC	(5) PART NUMBER	(6) DESCRIPTION AND USABLE ON CODE (UOC)	(7) QTY
GROUP 12 ELECTRICAL SYSTEM FIGURE 27 CEILING LIGHT - FIXED						
1	PAOZZ	6240-01-424-9648	097M6	F40CW/RS/WM	TUBE, FLUORESCENT.....	2
2	PAOZZ	6250-01-486-3452	98775	RC-2SP40-TP	BALLAST, FLUORESCENT LAMP.....	1
3	PAOZZ	6210-01-486-2396	39428	1626K31	FILTER, CLEAR.....	2
4	PAOZZ	6210-01-486-2402	39428	1626K4RED	FILTER, RED	2
NOTE: ITEM 3 OR 4 BY SPECIFIC FIXTURE						
5	PAOZZ	6210-01-486-1458	0U5N7	47012311	RETAINER, LIGHT TUBE.....	2
6	PAOZZ	6130-01-486-3737	097M6	PS-6000	ASSEMBLY, EMERGENCY LIGHT.....	1
NOTE: ITEM 6 FOR FIXTURE AT PERSONNEL DOOR ONLY						
END OF FIGURE						

**CONTAINERIZED KITCHEN (WITH TRAILER)
GROUP 12 ELECTRICAL SYSTEM
CEILING LIGHT - REMOVABLE**

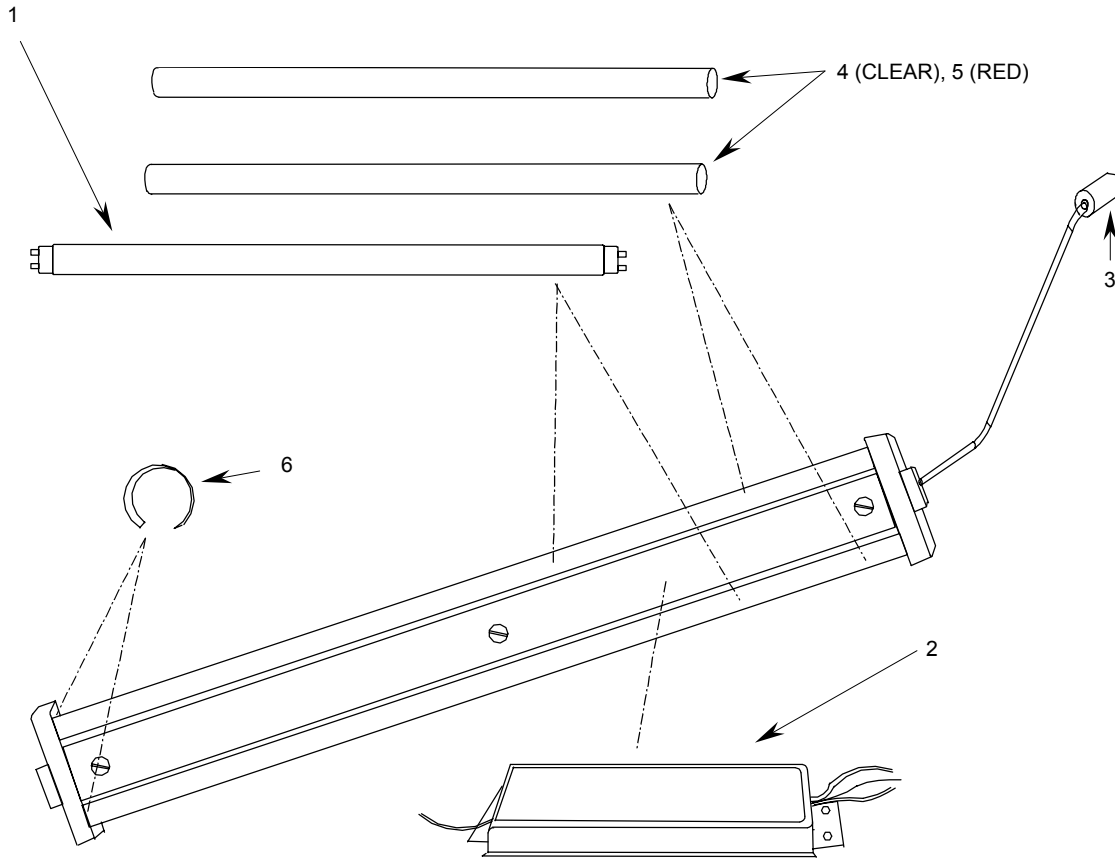

Figure 28. Ceiling Light – Removable.

**GROUP 12 ELECTRICAL SYSTEM
CEILING LIGHT – REMOVABLE
REPAIR PARTS LIST**

(1) ITEM NO.	(2) SMR CODE	(3) NSN	(4) CAGEC	(5) PART NUMBER	(6) DESCRIPTION AND USABLE ON CODE (UOC)	(7) QTY
					GROUP 12 ELECTRICAL SYSTEM FIGURE 28 CEILING LIGHT - REMOVABLE	
1	PAOZZ	6240-01-424-9648	097M6	F40CW/RS/WM	TUBE, FLUORESCENT.....	2
2	PAOZZ	6250-01-486-3452	98775	RC-2SP40-TP	BALLAST, FLUORESCENT LAMP.....	1
3	PAOZZ	5935-01-486-4756	097M6	7594V	PLUG, TWIST-LOC	1
4	PAOZZ	6210-01-486-2396	39428	1626K31	FILTER, CLEAR.....	2
5	PAOZZ	6210-01-486-2402	39428	1626K4RED	FILTER, RED	2
					NOTE: ITEM 4 OR 5 BY SPECIFIC FIXTURE	
6	PAOZZ	6210-01-486-1458	0U5N7	47012311	RETAINER, LIGHT TUBE.....	2
					END OF FIGURE	

**CONTAINERIZED KITCHEN (WITH TRAILER)
GROUP 99 BULK MATERIAL
REPAIR PARTS LIST**

(1) ITEM NO.	(2) SMR CODE	(3) NSN	(4) CAGEC	(5) PART NUMBER	(6) DESCRIPTION AND USABLE ON CODE (UOC)	(7) QTY
					GROUP 99 BULK MATERIAL FIGURE BULK	
1	PAOZZ	6145-01-486-3666	097M6	85022	CORD, TYPE SJOOW, 2 CONDUCTOR, 12 AWG (FOR COOK CENTER, OVEN ASSY POWER CABLES).....	1
2	PAOZZ	6145-01-486-3840	097M6	RM-WIRE12RED	WIRE, HOOKUP, THHN, 12 AWG RED (FOR COOK CENTER POWER CABLE)	1
3	PAOZZ	6145-01-486-3849	097M6	RM-WIRE12BLK	WIRE, HOOKUP, THHN, 12 AWG BLACK (FOR COOK CENTER POWER CABLE).....	1
4	PAOZZ	4720-01-486-3792	39428	5233K57	TUBING, PVC, 1/4" ID, 7/16" OD, CLEAR (FOR AIR CONDITIONER CONDENSATION DRAIN).....	1
					END OF FIGURE	

**CONTAINERIZED KITCHEN (WITH TRAILER)
SPECIAL TOOLS LIST**

No special tools are required to maintain the Containerized Kitchen (with Trailer) [CK].

**CONTAINERIZED KITCHEN (WITH TRAILER)
NATIONAL STOCK NUMBER INDEX**

STOCK NUMBER	FIG.	ITEM	STOCK NUMBER	FIG.	ITEM
4730-00-092-3883	9	6	6210-01-486-1458	28	6
4730-00-092-3883	13	5	6210-01-486-1824	15	8
5305-00-269-0770	1	9	5340-01-486-1825	16	3
5935-00-321-8295	10	2	6210-01-486-1826	15	7
5935-00-321-8295	14	1	5306-01-486-1828	3	2
5305-00-447-0122	4	12	5340-01-486-1832	15	1
5305-00-477-0122	4	14	5340-01-486-1916	15	2
5925-00-728-1969	23	7	5340-01-486-1936	1	2
4730-00-795-6959	9	7	4720-01-486-1981	13	1
4730-00-795-6959	13	6	5315-01-486-2020	3	3
5930-00-832-3269	22	5	5315-01-486-2021	3	6
5925-00-936-3933	23	4	5340-01-486-2219	3	4
6420-00-944-8202	16	10	5340-01-486-2238	1	1
5925-00-983-5666	23	5	6210-01-486-2396	27	3
5925-00-984-2163	23	1	6210-01-486-2396	28	4
5925-01-018-3041	23	2	6210-01-486-2402	27	4
5925-01-056-5127	23	6	6210-01-486-2402	28	5
5935-01-116-3615	10	1	5355-01-486-2419	5	5
5935-01-116-3615	14	2	5340-01-486-2436	19	2
4940-01-125-1755	11	6		20	1
5340-01-144-2649	9	8	5330-01-486-2447	15	9
5340-01-144-2649	13	7	5340-01-486-2450	17	2
2030-01-168-9371	20	3	5340-01-486-2455	16	4
6210-01-172-5978	24	4	5340-01-486-2457	11	1
5930-01-174-8604	24	6	5340-01-486-2469	19	3
6645-01-238-8659	11	8		20	2
5925-01-245-6479	23	3	5306-01-486-2475	22	6
5925-01-280-0280	25	4	5340-01-486-2477	11	2
5920-01-289-0884	24	7	5340-01-486-2490	17	3
5930-01-289-4219	11	5	5315-01-486-2498	3	8
5930-01-291-5467	24	3	4140-01-486-2783	8	1
5925-01-299-1282	25	6	5330-01-486-2809	1	4
5930-01-302-9739	24	1		19	11
5930-01-306-9740	24	5	5330-01-486-3183	15	10
5930-01-367-5513	24	2	6250-01-486-3452	27	2
5340-01-378-9445	4	2	6250-01-486-3452	28	2
6240-01-424-9648	27	1	4010-01-486-3503	2	2
6240-01-424-9648	28	1	6105-01-486-3600	7	6
5945-01-428-2685	5	3	4320-01-486-3601	19	5
7310-01-453-6513	4	11	6145-01-486-3666	Bulk	1
4510-01-465-5541	19	7	6685-01-486-3679	15	6
5930-01-480-4755	24	10	4130-01-486-3708	8	3
4720-01-482-0367	19	12	6150-01-486-3711	12	2
5310-01-483-6326	19	14		18	2
5330-01-486-1410	16	6		19	6
6210-01-486-1458	27	5	4510-01-486-3718	19	9

**CONTAINERIZED KITCHEN (WITH TRAILER)
NATIONAL STOCK NUMBER INDEX**

STOCK NUMBER	FIG.	ITEM	STOCK NUMBER	FIG.	ITEM
4720-01-486-3727	9	5	5930-01-486-4747	24	9
4720-01-486-3734	9	4	5930-01-486-4747	25	1
6130-01-486-3737	27	6	5930-01-486-4747	26	1
4720-01-486-3777	9	3	6685-01-486-4748	16	7
4520-01-486-3781	19	8	5930-01-486-4755	24	10
4720-01-486-3784	9	2	5930-01-486-4755	25	2
4720-01-486-3785	9	1	5930-01-486-4755	26	2
4720-01-486-3792	Bulk	4	5935-01-486-4756	12	2
2990-01-486-3801	4	7		25	7
3950-01-515-2999	2	1		28	3
4820-01-486-3823	17	4	6685-01-486-4758	16	8
6145-01-486-3840	Bulk	2	7195-01-486-5461	21	2
6145-01-486-3849	Bulk	3	9330-01-486-5500	16	9
4140-01-486-3873	18	1	7105-01-486-5929	21	1
6110-01-486-3904	22	1	7360-01-486-8328	15	3
5925-01-486-3911	25	5	5340-01-492-3315	2A	2
5340-01-486-4115	8	2	5120-01-493-1763	3	5
4730-01-486-4235	4	8	5340-01-493-9348	11	3
5930-01-486-4250	15	5	5340-01-493-9359	11	2
5999-01-486-4304	22	3	8340-01-495-0449	1	5
4720-01-486-4309	19	13	8340-01-495-0450	1	6
4720-01-486-4342	1	3	7310-01-502-9455	4	13
7310-01-486-4353	17	1	7230-01-503-0230	4	1
6105-01-486-4354	7	5	4520-01-508-5410	12	3
4720-01-486-4356	13	4	4720-01-508-7404	6	2
7310-01-486-4360	11	1	4720-01-508-7405	6	3
4730-01-486-4366	4	9	4720-01-508-7406	6	1
4110-01-486-4388	16	2	7230-01-515-2978	4	1
4110-01-486-4390	16	1	8340-01-515-2979	1	5
4540-01-486-4399	19	1	8340-01-515-2981	1	6
4720-01-486-4418	13	3	4720-01-515-2983	6	1
6130-01-486-4462	5	2	4720-01-515-2988	6	3
4720-01-486-4464	19	10	4720-01-515-2998	6	2
4120-01-486-4465	7	1	3950-01-515-2999	2	1
5998-01-486-4470	5	1	7360-01-516-0963	1	
6150-01-486-4603	15	4	4710-01-519-2747	18	4
6150-01-486-4603	16	5	4710-01-519-2748	18	4
6110-01-486-4604	22	2	5340-01-519-2751	4	12
4720-01-486-4606	13	2	5340-01-519-2753	4	5
5935-01-486-4703	25	3	5340-01-519-2755	4	6
5930-01-486-4714	24	8	4720-01-519-8206	18	3
5925-01-486-4721	22	4			
4140-01-486-4727	12	1			
5930-01-486-4740	5	4			
5930-01-486-4747	11	4			

**CONTAINERIZED KITCHEN (WITH TRAILER)
PART NUMBER INDEX**

<u>PART NUMBER</u>	<u>FIG.</u>	<u>ITEM</u>	<u>PART NUMBER</u>	<u>FIG.</u>	<u>ITEM</u>
060-3PJ-DW	11	2	47011056-2	4	1
	12	2	47011062	17	1
	18	2	47011084	11	1
	19	6	47012152-1	9	1
060-3PJ-DW-WK	11	3	47012152-2	13	2
10-5553	11	8		6	4
101-0100-5614	4	2	47012152-3	9	2
10291-JACK	3	7	47012152-4	13	3
10614-S-31	21	4	47012152-5	13	1
1450A2119	7	3	47012153-1	9	4
1452-1531	7	2	47012153-3	9	3
1452-1541	7	1	47012153-4	9	5
14597-000	16	10	47012175	4	5
1468A3029	7	4	47012177	4	
1468A3129	7	5	47012180	6	2
1626K31	27	3	47012180-2TAN	6	2
	28	4	47012181	6	1
1626K4RED	27	4	47012181-2TAN	6	1
	28	5	47012190	6	3
16830-000	16	7	47012190-2TAN	6	3
17465-000	16	8	47012196	4	10
17963-000	16	6	47012265	4	8
2088-594-154	19	5	47012266	12	3
2150K48	8	3	47012311	27	5
22785T63	19	2		28	6
	20	1	47012383	4	12
22785T68	19	3	47012399-1	18	4
	20	2	47012399-2	18	4
23605K52	19	4	47013007	10	3
2773K1	19	7		10	4
2834T39	16	3	47013009	14	3
2834T46	16	4	47013012	15	4
3891T16	20	3		16	5
40905	11	2	47013014	5	1
	12	2	47013023	22	3
	18	2	47016030	21	1
	19	6	47017001	1	
40910	25	3	47018028	1	5
44X	9	6	47018028-2TAN	1	5
47011026	16	2	47078028	1	5
47011028	19	1	4C727	12	1
47011031	16	1	4C865	8	1
47011034	7	1	50389-201	2	1
47011047	21	2	50389202	2A	3
47011050-1	1	3	50389214	1	2
47011050-2	19	10	50389-297	2	2
47011056-1	4	1	50389328	3	1
			50389330	3	8

**CONTAINERIZED KITCHEN (WITH TRAILER)
PART NUMBER INDEX**

PART NUMBER	FIG.	ITEM	PART NUMBER	FIG.	ITEM
50389341	3	2	HBL11SP	24	9
50389343	3	6		25	1
50389344	1	1		26	1
50389347	2A	1	HBL22SP	24	8
50389348	2A	8	HS13-Z	5	4
50389349	2A	5	LK-2490-BH	19	9
50389350	2A	6	KUMP-14018-12	5	3
50389351	2A	4	M-I-WH6U3SS	19	8
50389353	2A	7	MSO150	4	11
50389357	2A	2	MSO160	4	13
5233K57	BULK	4	MS3106F16-11P	10	1
5744	11	5		13	2
5SF2LRN2	11	6		14	2
601-SS	1	7	MS3106F16-11S	10	2
60401008	1	6		13	1
60401008-25TAN	1	6		14	1
62215T78	19	14			
6226T11	19	13	MS51861-47C	4	14
6226T12	19	12	MS51862-56C	1	9
6246-000	16	12	MS51862-59C	1	8
6815K13	4	6	N3030B	22	5
753-2454	5	5	PS-6000	27	6
7594V	12	2	P-SDC-2-HK	9	8
	25	7		13	6
	28	3	QOB110	23	6
800-1035	5	2	QOB115	23	1
8468-301	16	13	QOB115GFI	23	2
85022	BULK	1	QOB210	23	3
8689K31	16	9	QOB315	23	5
8921-045	16	11	QOB330	23	7
89417A	4	7	QOB360	23	4
91744A583	4	3	RC-2SP40-TP	27	2
9376K113	8	2		28	2
94800A730	4	4	RM-WIRE12BLK	BULK	3
98-1480	11	7	RM-WIRE12RED	BULK	2
98812A030	22	6	RPB5D	15	1
9908T18	17	2	RPB5NB	15	2
9908T31	17	3	RPC06-317	15	10
A128	18	1	RPC07-032-23.250	15	9
B03	1	4	RPC13-064	15	8
	19	11	RPC13-105	15	7
B2-H16	9	7	RPC13-127	15	5
B6002	17	4	RPC13-129	15	6
C18080-S-31	21	3	SSB1	24	2
DPA63-V02	22	1		24	10
DPA-D11	22	2		26	2
F40CW/RS/WM	27	1	RP-HM2000	15	3
	28	1		25	2
HBL11SP	11	4	RP-HM2000	26	2

CONTAINERIZED KITCHEN (WITH TRAILER)
PART NUMBER INDEX

PART NUMBER	FIG.	ITEM
W28XQ1A-1	25	6
W28XQ1A-2	25	4
W28XQ1A-6	25	5
W58-XB4A4A-5	22	4
ZB2BA2	24	1
ZB2BT4	24	5
ZB2BV05	24	4
ZB2BW061	24	3
ZB2BW33	24	2
ZB2BZ102	24	7
ZB2BZ104	24	6

**CONTAINERIZED KITCHEN (WITH TRAILER)
COMPONENTS OF END ITEM AND BASIC ISSUE ITEMS LISTS**

INTRODUCTION**Scope**

This work package lists the Components of End Item (COEI) and Basic Issue Items (BII) for the CK to help you inventory items for safe and efficient operation of the equipment.

General

The COEI and BII information is divided into the following lists:

Components of End Item (COEI). This list is for information purposes only and is not authority to requisition replacements. These items are part of the CK. As part of the end item, these items must be with the end item whenever it is issued or transferred between property accounts. Items of COEI are removed and separately packaged for transportation or shipment only when necessary. Illustrations are furnished to help you find and identify the items.

Basic Issue Items (BII). These essential items are required to place the CK in operation, operate it, and to do emergency repairs. Although shipped separately packaged, BII must be with the CK during operation and when it is transferred between property accounts. Listing these items is your authority to request/requisition them for replacement based on authorization of the end item by the TOE/MTOE. Illustrations are furnished to help you find and identify the items.

Explanation of Columns in the COEI List and BII List

Column (1) – Illus Number. Gives you the number of the item illustrated.

Column (2) – National Stock Number (NSN). Identifies the stock number of the item to be used for requisitioning purposes.

Column (3) – Description, Commercial and Government Entity Code (CAGEC), and Part Number (P/N). Identifies the Federal item name (in all capital letters) followed by a minimum description when needed. The stowage location of COEI and BII is also included in this column. The last line below the description is the CAGEC (in parentheses) and the part number.

Column (4) – Usable On Code. When applicable, gives you a code if the item you need is not the same for different models of equipment.

Column (5) – Unit of Measure (U/M). Indicates the physical measurement or count of the item as issued per the National Stock Number (NSN) shown in column (2).

Column (6) – Qty Rqr. Indicates the quantity required.

**CONTAINERIZED KITCHEN (WITH TRAILER)
COMPONENTS OF END ITEM AND BASIC ISSUE ITEMS LISTS**

COMPONENTS OF END ITEM (COEI) LIST

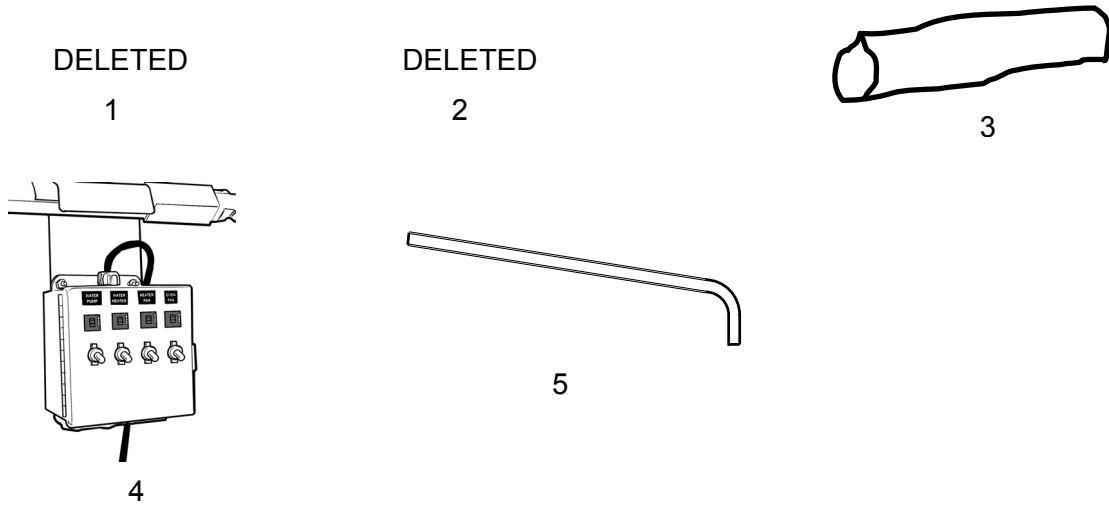
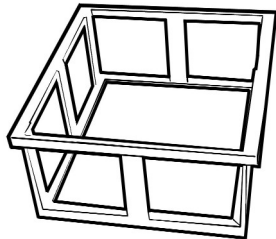

Table 1. Components of End Item List.

(1) ILLUS NUMBER	(2) NATIONAL STOCK NUMBER	(3) DESCRIPTION, (CAGEC) AND PART NUMBER	(4) USABLE ON CODE	(5) U/M	(6) QTY RQR
1		DELETED			
2		DELETED			
3	4720-01-508-7406	AIR DISCHARGE DUCT, ECU, Green (1M877) 47012181		EA	1
3	4720-01-508-7404	AIR DISCHARGE DUCT, GENERATOR, Green (1M877) 47012180		EA	1
3	4720-01-508-7405	AIR DISCHARGE DUCT, VENT HOOD, Green (1M877) 47012190		EA	1
3	4720-01-515-2983	AIR DISCHARGE DUCT, ECU, Tan (1M877) 47012181-2TAN		EA	1
3	4720-01-515-2998	AIR DISCHARGE DUCT, GENERATOR, Tan (1M877) 47012180-2TAN		EA	1
3	4720-01-515-2988	AIR DISCHARGE DUCT, VENT HOOD, Tan (1M877) 47012190-2TAN		EA	1
4		APPLIANCE CONTROL BOX (0U5N7) 47013001		EA	1
5	5340-01-492-3315	ARCH, SHELTER (80298) 50389347		EA	10

**CONTAINERIZED KITCHEN (WITH TRAILER)
COMPONENTS OF END ITEM AND BASIC ISSUE ITEMS LISTS**



6

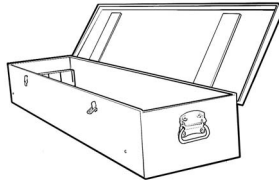

7

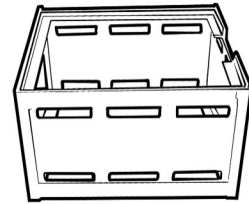

8

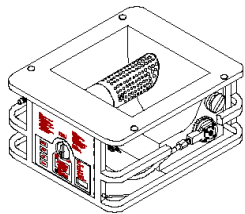

9

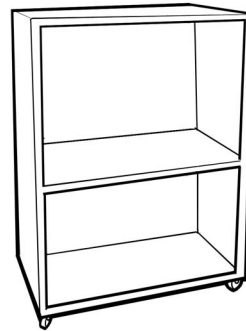

10

Table 1. Components of End Item List – Continued.

(1) ILLUS NUMBER	(2) NATIONAL STOCK NUMBER	(3) DESCRIPTION, (CAGEC) AND PART NUMBER	(4) USABLE ON CODE	(5) U/M	(6) QTY RQR
6		BASE RACK ASSEMBLY (0U5N7) 47016042		EA	1
7		BOX, LIGHT STORAGE (0U5N7) 47011041		EA	1
8		BURNER RACK ASSEMBLY (0U5N7) 47016041		EA	1
9	7310-01-452-8137 OR 7310-01-507-9310	BURNER UNIT, MODERN (MBU) (3AD06) MS0001 BURNER UNIT, MODERN (MBU) (3AD06) MS0003		EA	6
10		CABINET, MOBILE STORAGE (0U5N7) 47012111		EA	2

**CONTAINERIZED KITCHEN (WITH TRAILER)
COMPONENTS OF END ITEM AND BASIC ISSUE ITEMS LISTS**

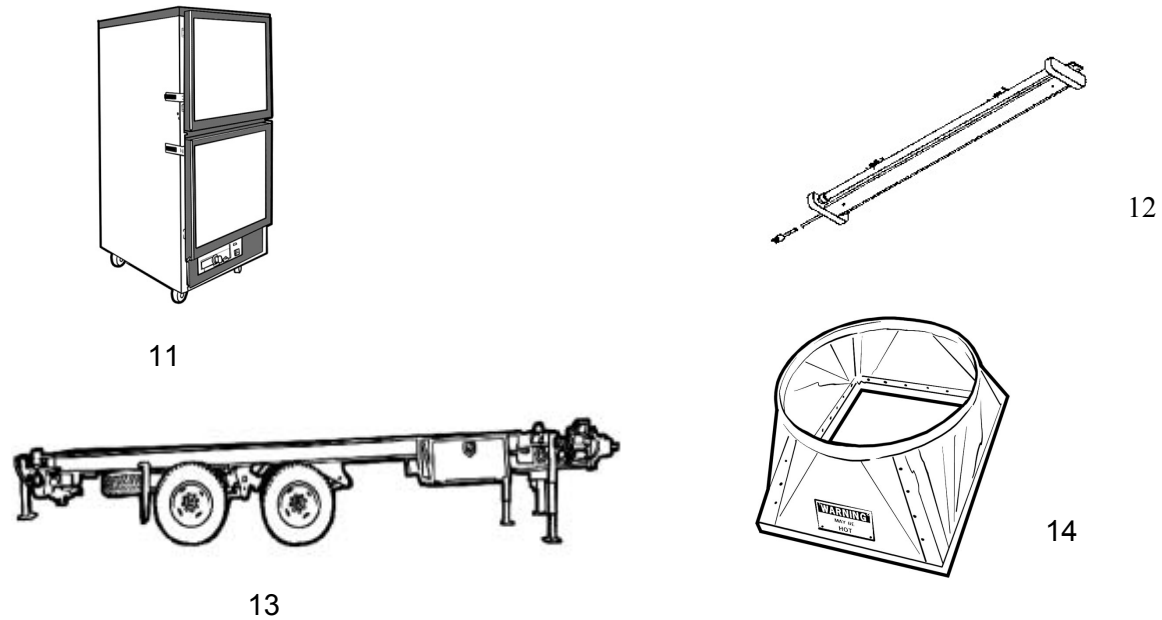
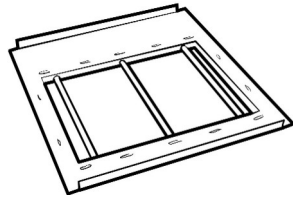

Table 1. Components of End Item List – Continued.

(1) ILLUS NUMBER	(2) NATIONAL STOCK NUMBER	(3) DESCRIPTION, (CAGEC) AND PART NUMBER	(4) USABLE ON CODE	(5) U/M	(6) QTY RQR
11		CABINET, MOBILE WARMING (0U5N7) 47011063		EA	1
12		CEILING LIGHT, REMOVABLE (0U5N7) 47013003-1		EA	3
12		CEILING LIGHT, REMOVABLE, BLACKOUT (0U5N7) 47013003-2		EA	2
13	2330-01-471-7006 OR 2330-01-506-5979	CHASSIS, TRAILER (2W888) 1103-1000-00 CHASSIS, TRAILER (2W888) 1103-3000-00		EA	1
14		COOK POT CRADLE (0U5N7) 47016040		EA	2

**CONTAINERIZED KITCHEN (WITH TRAILER)
COMPONENTS OF END ITEM AND BASIC ISSUE ITEMS LISTS**



15

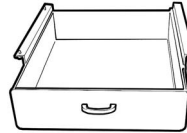

16

DELETED

17

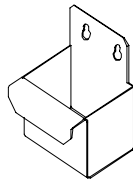

18

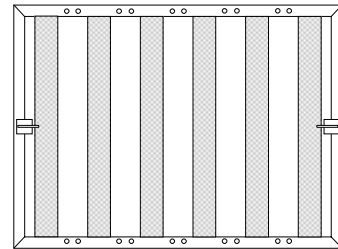

19

Table 1. Components of End Item List – Continued.

(1) ILLUS NUMBER	(2) NATIONAL STOCK NUMBER	(3) DESCRIPTION, (CAGEC) AND PART NUMBER	(4) USABLE ON CODE	(5) U/M	(6) QTY RQR
15		COOK POT CRADLE ADAPTER (0U5N7) 47012254		EA	4
16	7195-01-486-5461	DRAWER ASSEMBLY (0U5N7) 47011047		EA	2
17		DELETED			
18	7360-01-496-6839	CONTAINER EXCESS (0U5N7) 47012124		EA	1
19	7330-01-492-0372	FILTER, COOKING GREASE (26116) KG-2016/21		EA	7

**CONTAINERIZED KITCHEN (WITH TRAILER)
COMPONENTS OF END ITEM AND BASIC ISSUE ITEMS LISTS**

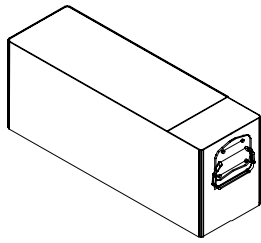

20

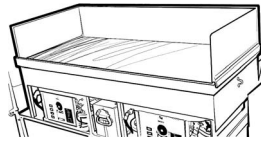

21

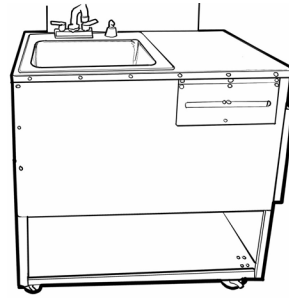

22



23

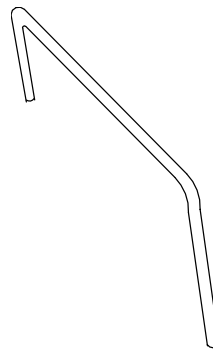

24

Table 1. Components of End Item List – Continued.

(1) ILLUS NUMBER	(2) NATIONAL STOCK NUMBER	(3) DESCRIPTION, (CAGEC) AND PART NUMBER	(4) USABLE ON CODE	(5) U/M	(6) QTY RQR
20		GREASE CONTAINER (0U5N7) 47012003		EA	1
21		GRIDDLE ASSEMBLY (0U5N7) 4011035		EA	1
22	4540-01-486-4399	SINK ASSEMBLY, HAND (0U5N7) 47011028		EA	1
23	5340-01-486-2219	HANDLE, JACK/WINCH (80298) 50389298		EA	2
24		HANDRAIL, STAIR (0U5N7) 47012314		EA	6

**CONTAINERIZED KITCHEN (WITH TRAILER)
COMPONENTS OF END ITEM AND BASIC ISSUE ITEMS LISTS**

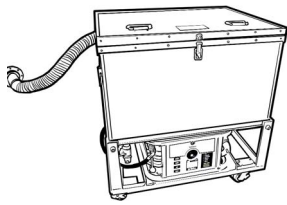

25

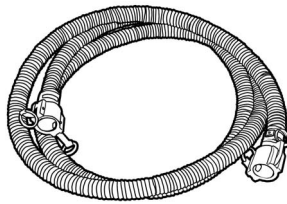

26

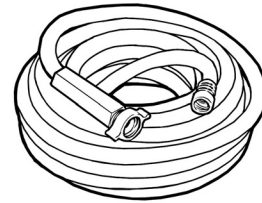

27

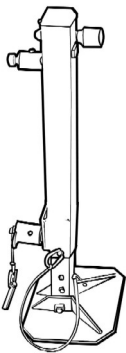

28

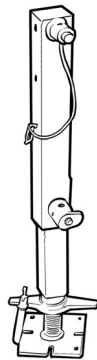

29

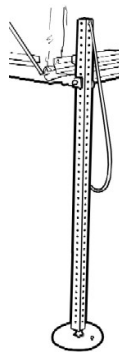

30

DELETED

31

Table 1. Components of End Item List – Continued.

(1) ILLUS NUMBER	(2) NATIONAL STOCK NUMBER	(3) DESCRIPTION, (CAGEC) AND PART NUMBER	(4) USABLE ON CODE	(5) U/M	(6) QTY RQR
25	7310-01-486-4353	HEATER, TRAY PACK (0U5N7) 47011062		EA	1
26	4720-01-486-4342	HOSE ASSEMBLY, NONMETALLIC (8B051) 47011050-1		EA	1
26	4720-01-486-4464	HOSE ASSEMBLY, DRAIN, INTERNAL (0U5N7) 47011050-2		EA	1
27	4720-01-486-4309	HOSE, WATER SUPPLY, 25-ft (39428) 6226T11		EA	2
27	4720-01-482-0367	HOSE, WATER SUPPLY, 50-ft (39428) 6626T12		EA	1
28		JACK, CORNER (80298) 50389328		EA	2
29		JACK, SCREW (2C081) 10291-JACK		EA	2
30	5120-01-493-1762	JACK, WING (2C081) 10239-JACK		EA	8
31		DELETED			

**CONTAINERIZED KITCHEN (WITH TRAILER)
COMPONENTS OF END ITEM AND BASIC ISSUE ITEMS LISTS**

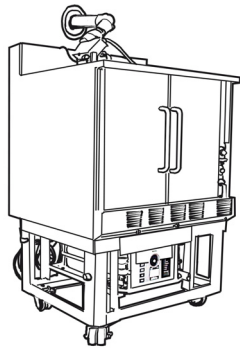

32

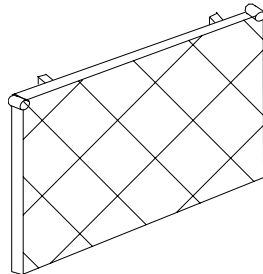

33

DELETED

34

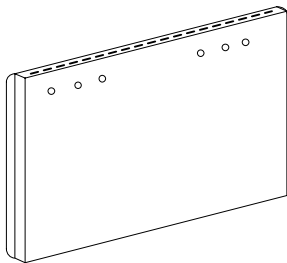

35

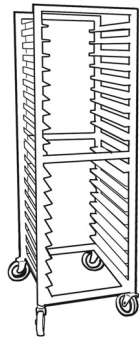

36

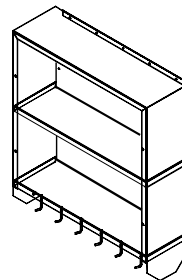

37

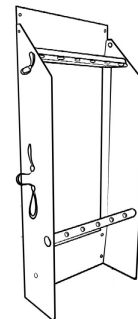

38

Table 1. Components of End Item List – Continued.

(1) ILLUS NUMBER	(2) NATIONAL STOCK NUMBER	(3) DESCRIPTION, (CAGEC) AND PART NUMBER	(4) USABLE ON CODE	(5) U/M	(6) QTY RQR
32	7310-01-486-4360	OVEN ASSEMBLY, SINGLE (0U5N7) 47011084		EA	1
33		PLATFORM (0U5N7) 47012320		EA	1
34		DELETED			
35		RACK, KNIFE (0U5N7) 47011075		EA	1
36		RACK, PAN (0U5N7) 47016047		EA	1
37		RACK, SPICE (0U5N7) 47012239		EA	1
38	8145-01-385-7524	WEAPONS RACK, REPLACEMENT (80298) 60042-002		EA	1

**CONTAINERIZED KITCHEN (WITH TRAILER)
COMPONENTS OF END ITEM AND BASIC ISSUE ITEMS LISTS**

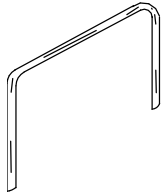

39

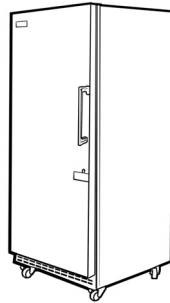

40

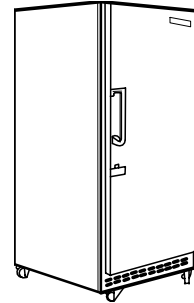

41

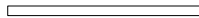

42

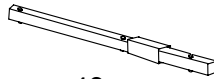

43



44

Table 1. Components of End Item List – Continued.

(1) ILLUS NUMBER	(2) NATIONAL STOCK NUMBER	(3) DESCRIPTION, (CAGEC) AND PART NUMBER	(4) USABLE ON CODE	(5) U/M	(6) QTY RQR
39		RAIL, PLATFORM (0U5N7) 47012321		EA	1
40	4110-01-486-4390	REFRIGERATOR, LEFT HAND (0U5N7) 47011031		EA	1
41	4110-01-486-4388	REFRIGERATOR, RIGHT HAND (0U5N7) 47011026		EA	1
42		SPACER, ARCH (80298) 50389350		EA	5
43		SPACER, ARCH, ADJUSTABLE (80298) 50389351		EA	1
44		SPACER, ARCH, CURVED (80298) 50389202		EA	2

**CONTAINERIZED KITCHEN (WITH TRAILER)
COMPONENTS OF END ITEM AND BASIC ISSUE ITEMS LISTS**

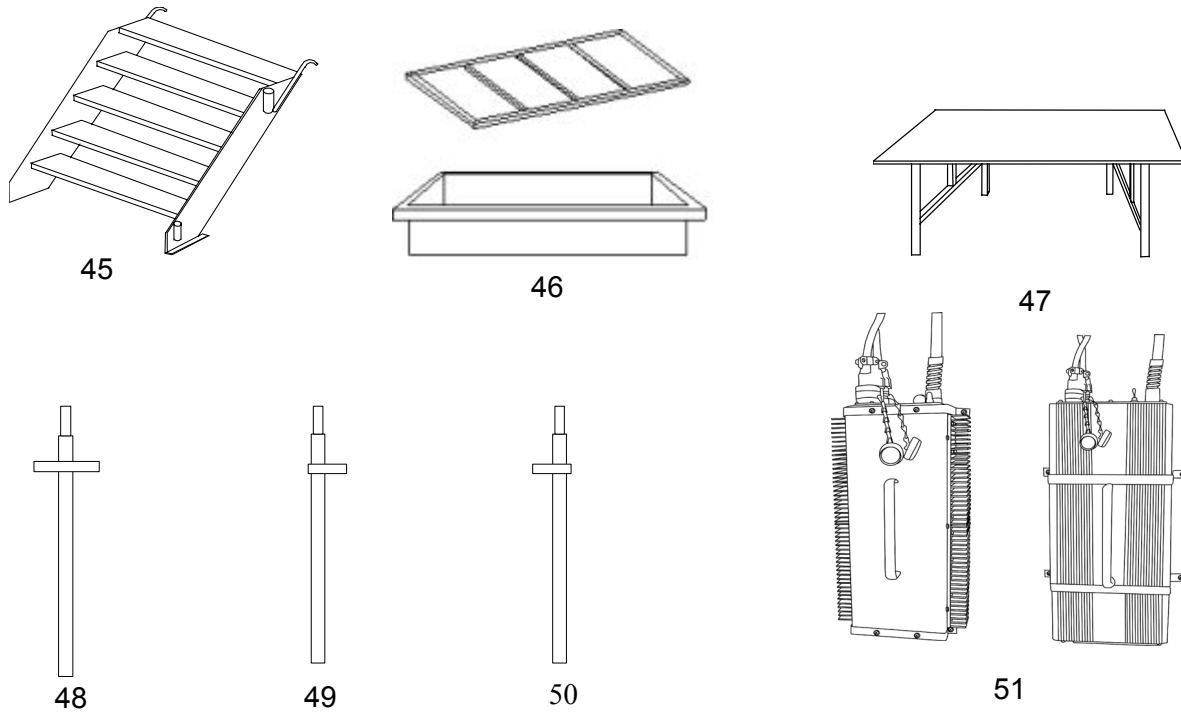
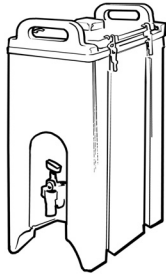

Table 1. Components of End Item List – Continued.

(1) ILLUS NUMBER	(2) NATIONAL STOCK NUMBER	(3) DESCRIPTION, (CAGEC) AND PART NUMBER	(4) USABLE ON CODE	(5) U/M	(6) QTY RQR
45		STAIR ASSEMBLY (0U5N7) 47012324		EA	3
46	7310-01-519-3553 AND 7310-01-518-9053	STEAM TABLE ADAPTER TOP (0U5N7) 47012144 STEAM TABLE (0U5N7) 47011036		EA	1
47		TABLE, FIELD, ALTERED (0U5N7) 47011049		EA	4
48		VERTICAL, "X" (80298) 50389353		EA	6
49		VERTICAL, "T", LEFT SIDE (80298) 50389348		EA	2
50		VERTICAL, "T", RIGHT SIDE (80298) 50389349		EA	2
51	7310-01-453-6513 OR 7310-01-502-9455	POWER CONVERTER, MBU (3AD06) MS0150 STANDARD ON CK UNITS SERIAL NUMBER CK000150 AND LOWER POWER CONVERTER, MBU (3AD06) MS0160 STANDARD ON CK UNITS SERIAL NUMBER CK000151 AND HIGHER		EA	1

**CONTAINERIZED KITCHEN (WITH TRAILER)
COMPONENTS OF END ITEM AND BASIC ISSUE ITEMS LISTS**

BASIC ISSUE ITEMS (BII) LIST



1

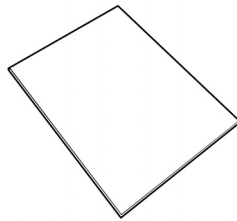

2

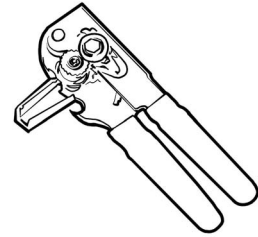

3



4



5

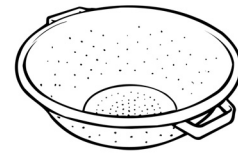

6

Table 2. Basic Issue Items List.

(1) ILLUS NUMBER	(2) NATIONAL STOCK NUMBER	(3) DESCRIPTION, (CAGEC) AND PART NUMBER	(4) USABLE ON CODE	(5) U/M	(6) QTY RQR
1	7310-01-245-6937	BEVERAGE DISPENSER (58536) A52190-2-2		EA	8
2	7330-00-078-5706	BOARD, FOOD CHOPPING & SLICING (58536) A-A-391		EA	2
3	7330-01-245-0201	CAN OPENER, HAND (81337) 5-13-3971		EA	2
4	7240-01-337-5269	CAN, FUEL (81349) MIL-C-53109		EA	3
5	7240-00-089-3827	CAN, WATER (81349) MIL-C-43613 Type 1		EA	6
6	7330-00-266-7453	COLANDER, STAINLESS STEEL (58536) A-A-469		EA	1

**CONTAINERIZED KITCHEN (WITH TRAILER)
COMPONENTS OF END ITEM AND BASIC ISSUE ITEMS LISTS**

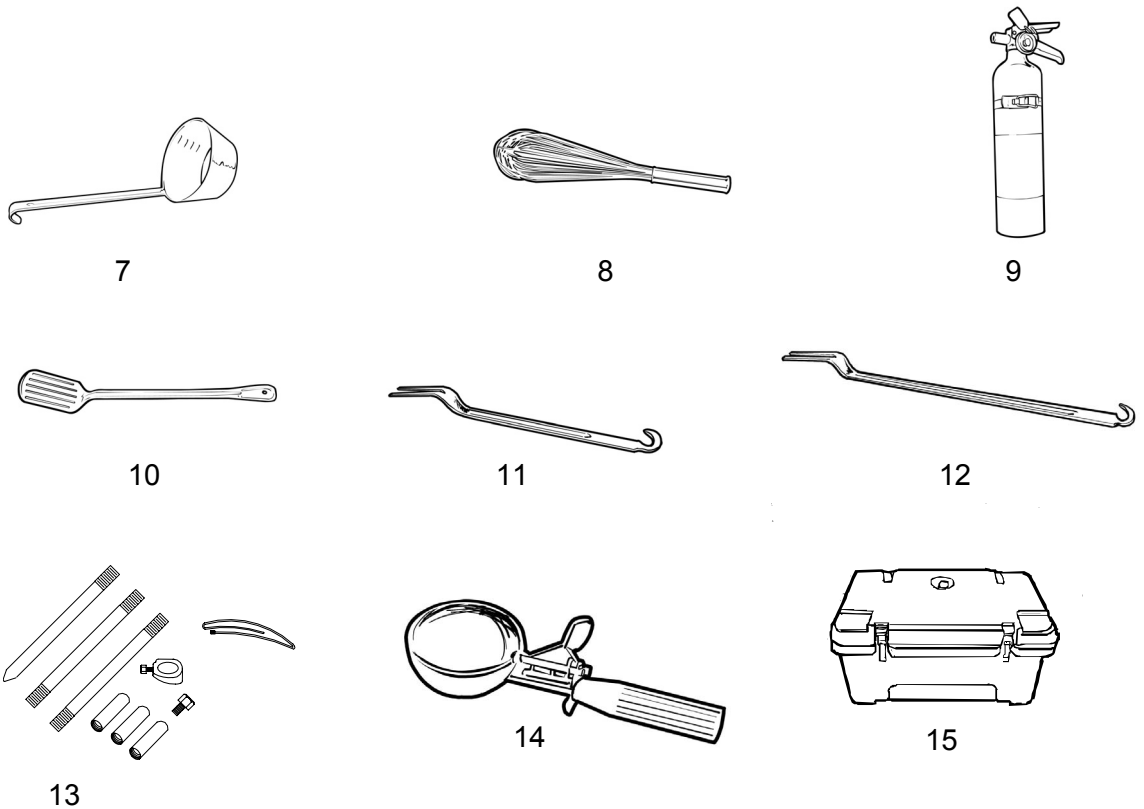

Table 2. Basic Issue Items List – Continued.

(1) ILLUS NUMBER	(2) NATIONAL STOCK NUMBER	(3) DESCRIPTION, (CAGEC) AND PART NUMBER	(4) USABLE ON CODE	(5) U/M	(6) QTY RQR
7	7330-00-272-2489	DIPPER, 32 oz. (58536) A-A-1752		EA	4
8	7330-00-815-1458	EGG WHIP (58536) A-A-394		EA	2
9	4210-01-324-5194	FIRE EXTINGUISHER, DRY CHEMICAL (39428) 6487T1		EA	4
10	7330-00-256-2158	FOOD TURNER (58536) A-A-52204		EA	4
11	7340-00-223-7791	FORK, FOOD PREPARATION, 15 in. (58536) A-A-52204		EA	4
12	7340-00-223-7792	FORK, FOOD PREPARATION, 21 in. (58536) A-A-52204		EA	4
13	3820-00-930-6086	GROUND ROD ASSEMBLY (18990) 30162		EA	1
14	7330-00-197-1280	ICE CREAM SCOOP, Size 6 (58536) A-A-43		EA	4
15	7360-01-408-4911	INSULATED FOOD TRANSPORTER (58536) A-A-52193		EA	16

**CONTAINERIZED KITCHEN (WITH TRAILER)
COMPONENTS OF END ITEM AND BASIC ISSUE ITEMS LISTS**



16

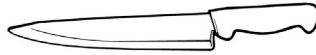

17



18

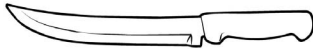

19

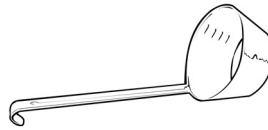

20



21



22

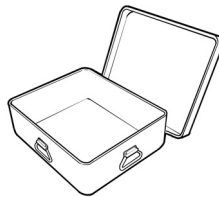

23

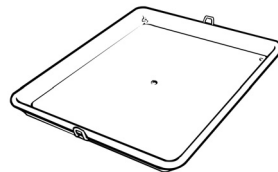

24

Table 2. Basic Issue Items List – Continued.

(1) ILLUS NUMBER	(2) NATIONAL STOCK NUMBER	(3) DESCRIPTION, (CAGEC) AND PART NUMBER	(4) USABLE ON CODE	(5) U/M	(6) QTY RQR
16	7340-00-197-1271	KNIFE, BONING, 10 in. (4Y739) 6447M		EA	3
17	7340-00-488-7950	KNIFE, COOK'S, 10 in. (58536) A-A-2733		EA	3
18	7340-00-488-7939	KNIFE, PARING, 3.25 in. (58536) A-A-2733		EA	4
19	7340-00-197-1274	KNIFE, STEAK, SCIMITAR (58536) A-A-2733		EA	3
20	7330-00-248-1153	LADLE, KITCHEN, 8 oz. (80244)		EA	4
21	7330-00-264-5368	MEASURING CUP, 4 qt. (58536) A-A-1751		EA	2
22	7330-00-272-7876	MEASURING SET, SPOON (80244)		EA	2
23	7330-00-263-8504	PAN, BAKING & ROASTING (58536) A-A-52201		EA	4
24	7330-00-272-2589	PAN, BAKING & ROASTING (81349) MIL-P-12851		EA	10

**CONTAINERIZED KITCHEN (WITH TRAILER)
COMPONENTS OF END ITEM AND BASIC ISSUE ITEMS LISTS**

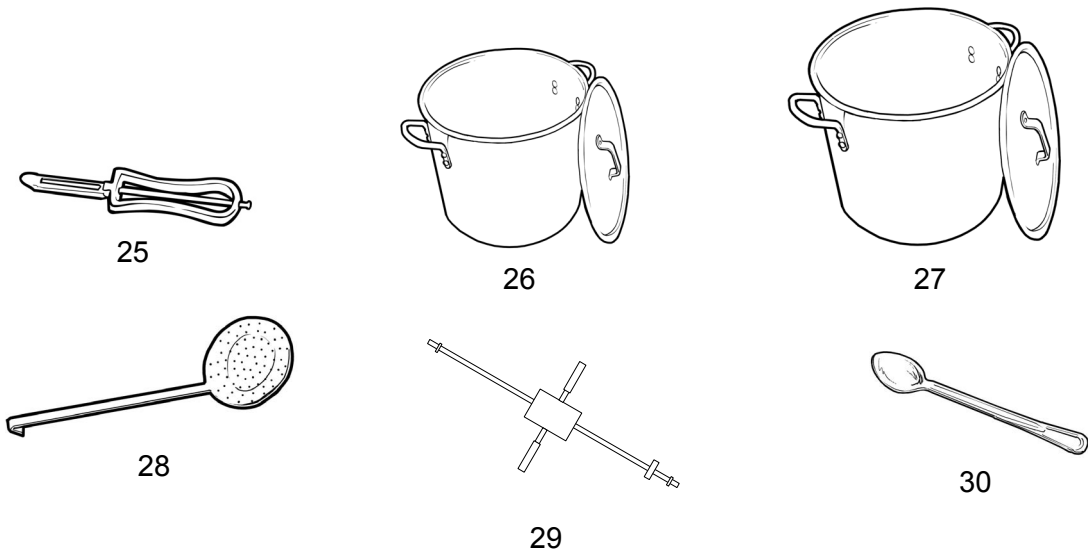

Table 2. Basic Issue Items List – Continued.

(1) ILLUS NUMBER	(2) NATIONAL STOCK NUMBER	(3) DESCRIPTION, (CAGEC) AND PART NUMBER	(4) USABLE ON CODE	(5) U/M	(6) QTY RQR
25	7330-00-238-8316	PEELER, POTATO, HAND (85812) W8097		EA	3
26	7330-00-292-2306	POT, COOKING, 10 gal., with Cover (81337) 2-9-35		EA	3
27	7330-00-292-2307	POT, COOKING, 15 gal., with Cover (81337) 2-9-120		EA	3
28	7330-00-680-2635	SKIMMER, KITCHEN (58536) A-A-1072		EA	2
29	5120-01-013-1676	SLIDE HAMMER, GROUND ROD (97403) 13226E7741		EA	1
30	7340-00-240-7080	SPOON, FOOD SERVICE, 15 in. (58536) A-A-1082		EA	4

**CONTAINERIZED KITCHEN (WITH TRAILER)
COMPONENTS OF END ITEM AND BASIC ISSUE ITEMS LISTS**

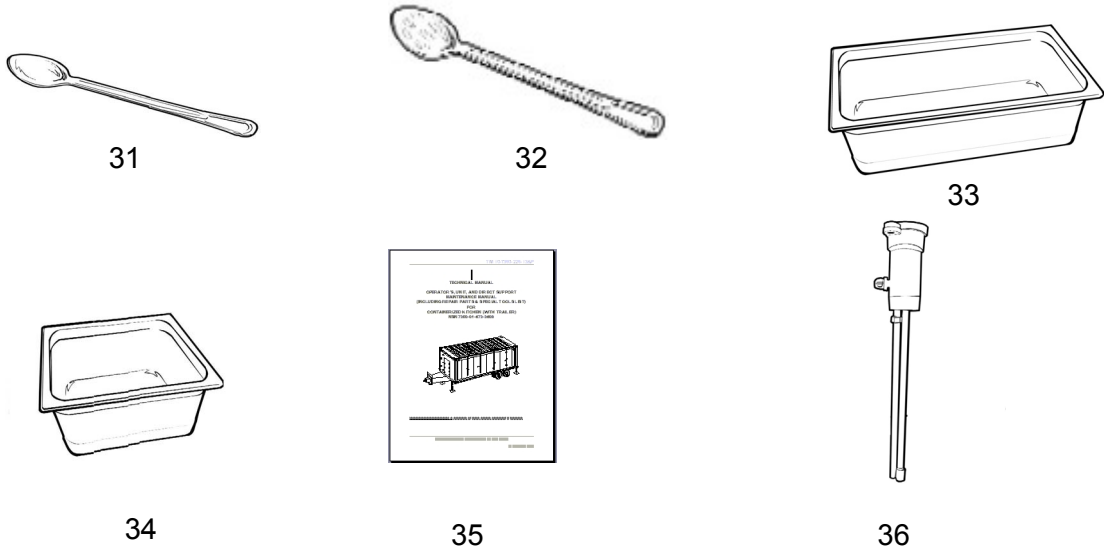
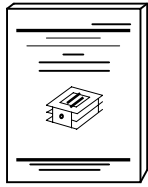

Table 2. Basic Issue Items List – Continued.

(1) ILLUS NUMBER	(2) NATIONAL STOCK NUMBER	(3) DESCRIPTION, (CAGEC) AND PART NUMBER	(4) USABLE ON CODE	(5) U/M	(6) QTY RQR
31	7340-00-223-7800	SPOON, FOOD SERVICE, 21 in. (58536) A-A-52204		EA	4
32	7340-00-205-1421	SPOON, FOOD SERVICE, SLOTTED (58536) A-A-1082		EA	4
33		STEAM TABLE PAN, FULL SIZE (0U5N7) 47016028		EA	8
34		STEAM TABLE PAN, HALF SIZE (0U5N7) 47016029		EA	4
35		TECHNICAL MANUAL TM 10-7360-226-13&P		EA	1
36	2910-00-066-1235	ADAPTER, FUEL, GENERATOR (97403) 13211E7541		EA	1

**CONTAINERIZED KITCHEN (WITH TRAILER)
COMPONENTS OF END ITEM AND BASIC ISSUE ITEMS LISTS**



37

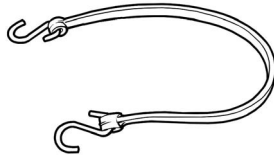

38

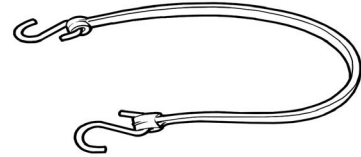

39

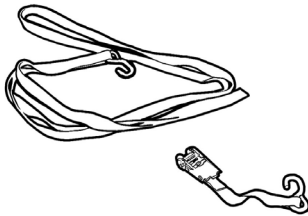

40

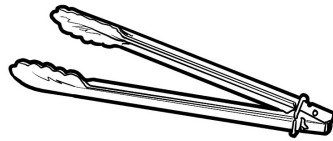

41

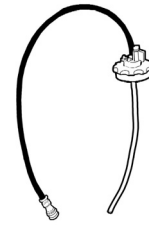

42



43

Table 2. Basic Issue Items List – Continued.

(1) ILLUS NUMBER	(2) NATIONAL STOCK NUMBER	(3) DESCRIPTION, (CAGEC) AND PART NUMBER	(4) USABLE ON CODE	(5) U/M	(6) QTY RQR
37		TECHNICAL MANUAL TM 10-7310-281-13&P		EA	1
38	2030-01-168-9371	TIE-DOWN, RUBBER, 28 in. (39428) 3891T16		EA	21
39	5340-01-492-4109	TIE-DOWN, RUBBER, 35 in. (39428) 3891T19		EA	4
40		TIE-DOWN STRAP, RATCHET (78325) 126-724		EA	19
41	7330-00-616-0997	TONGS, FOOD SERVICE, 12 in. (64067)		EA	4
42	7310-01-455-3736	ADAPTER, FUEL, MBU (3AD06) MS0300		EA	1
43	6545-00-656-1094	KIT, FIRST AID (04024) 6170-6 TY3		EA	1

**CONTAINERIZED KITCHEN (WITH TRAILER)
ADDITIONAL AUTHORIZATION LIST (AAL)**

INTRODUCTION

Scope

This work package lists additional items you are authorized for the support of the CK.

Explanation of Columns in the AAL

Column (1) – National Stock Number (NSN). Identifies the stock number of the item to be used for requisitioning purposes.

Column (2) - Description, Commercial and Government Entity Code (CAGEC), and Part Number (P/N). Identifies the Federal item name (in all capital letters) followed by a minimum description when needed. The stowage location of COEI and BII is also included in this column. The last line below the description is the CAGEC (in parentheses) and the part number.

Column (3) - Usable On Code. When applicable, gives you a code if the item you need is not the same for different models of equipment.

Column (4) - Unit of Measure (U/M). Indicates the physical measurement or count of the item as issued per the National Stock Number (NSN) shown in column (1).

Column (5) – Qty Recm. Indicates the quantity recommended.

ADDITIONAL AUTHORIZATION LIST ITEMS

Table 1. Additional Authorization List.

(1) NATIONAL STOCK NUMBER	(2) DESCRIPTION, (CAGEC) AND PART NUMBER	(3) USABLE ON CODE	(4) U/M	(5) QTY RECM
5935-00-114-8708	CONNECTOR, RECEPTACLE, ELECTRICAL (81349) MIL-C-22922		EA	1
7310-01-454-1241	ELECTRIC ADAPTER, MBU (81349) MIL-PRF-44485		EA	1
7310-01-458-5060	EXTENSION CORD, 110 VAC, 25 FT (3AD06) MS0425		EA	2

**CONTAINERIZED KITCHEN (WITH TRAILER)
EXPENDABLE AND DURABLE ITEMS LIST**

P1S1INTRODUCTION

Scope

This work package lists expendable and durable items that you will need to operate and maintain the CK. This list is for information only and is not authority to requisition the listed items. These items are authorized to you by CTA 50-970, Expendable/Durable Items (Except Medical, Class V Repair Parts, and Heraldic Items), or CTA 8-100, Army Medical Department Expendable/Durable Items.

Explanation of Columns in the Expendable and Durable Items List

Column (1) – Item Number. This number is assigned to the entry in the list and is referenced in the narrative instructions to identify the item (e.g.,” Use brake fluid (item 5, WP 0098 00).”).

Column (2) – Level. This column identifies the lowest level of maintenance that requires the listed item (C = Operator/Crew).

Column (3) – National Stock Number (NSN). This is the NSN assigned to the item which you can use to requisition it.

Column (4) – Item Name, Description, Commercial and Government Entity Code (CAGEC), and Part Number (P/N). This column provides the other information you need to identify the item.

Column (5) – Unit of Measure (U/M). This code shows the physical measurement or count of an item, such as gallon, dozen, gross, etc.

EXPENDABLE AND DURABLE ITEMS LIST

Table 1. Expendable and Durable Items List.

(1) ITEM NO.	(2) LEVEL	(3) NSN	(4) ITEM NAME, DESCRIPTION, (CAGEC), PART NUMBER	(5) U/M
1	C	5340-01-516-5289	PAD, CUSHION (39428) 2256T11	EA
2	C	7920-01-338-3329	CLOTH, CLEANING (21994) TX-1250	BG
3	C		COMPOUND, PIPE JOINT (53472) 31226	EA
4	C	9150-01-197-7690	GREASE, AUTOMOTIVE (81349) M-10924-C	CN
5	C	6850-01-265-3115	LUBRICANT, SILICONE (10136) 03030	EA
6	C	9150-01-152-4117	LUBRICATING OIL, ENGINE (81349) MIL-L-2104, OEA HDO 15/40	QT
7	C		TAPE, FABRIC REPAIR (1TVK0) 1744	EA
8	C		TIE, HOOK AND LOOP, 6-INCH (PACK OF 10) (39428) 6605K12	EA
9	C		TIE, HOOK AND LOOP, 8-INCH (PACK OF 10) (39428) 6605K11	EA
10	C	8030-00-180-6339	CAULKING COMPOUND, CLEAR, 10 OZ. TUBE(58536) A-A-272	CA

**CONTAINERIZED KITCHEN (WITH TRAILER
TOOL IDENTIFICATION LIST)**

INTRODUCTION**Scope**

This work package lists all common tools and supplements and special tools/fixtures needed to maintain the CK.

Explanation of Columns in the Tool Identification List

Column (1) – Item Number. This number is assigned to the entry in the list and is referenced in the initial setup to identify the item (e.g., Extractor (item 32, WP 0090 00)).

Column (2) – Item Name. This column lists the item by noun nomenclature and other descriptive features (e.g., Gage, belt tension).

Column (3) – National Stock Number. This is the National Stock Number (NSN) assigned to the item; use it to requisition the item.

Column (4) – Part Number. Indicates the primary number used by the manufacturer (individual, company, firm, corporation, or Government activity) which controls the design and characteristics of the item by means of its engineering drawings, specifications, standards, and inspection requirements to identify an item or range of items.

Column (5) – Reference. This column identifies the authorizing supply catalog or RPSTL for items listed in this work package.

TOOL IDENTIFICATION LIST**Table 1. Tool Identification List.**

(1) ITEM NO.	(2) ITEM NAME	(3) NATIONAL STOCK NUMBER	(4) PART NUMBER	(5) REFERENCE
1	TOOL KIT, GENERAL MECHANIC'S (GMTK)	5180-01-454-3787	12B470000	SC 5180-95-B47
2	SHOP EQUIPMENT, WELDING	4940-01-090-1231	11022000	

**CONTAINERIZED KITCHEN (WITH TRAILER)
MANDATORY REPLACEMENT PARTS**

Refer to TM 10-7310-281-13&P for mandatory replacement parts for the MBUs.

The only mandatory replacement part for the generator is the oil filter. Refer to LO 9-6115-642-12 for replacement information and procedure.

There are no mandatory replacement parts for any other components of the CK.

There are no mandatory replacement parts for the CK trailer.

**CONTAINERIZED KITCHEN (WITH TRAILER)
WIRING DIAGRAMS**

INTRODUCTION**Scope**

This work package describes the wiring provisions contained in the Containerized Kitchen (with Trailer) [CK], including all systems or equipment which can be installed or removed later. Wiring diagrams and essential wiring information are provided for all electrical systems and circuits. All critical wire and cable data has been included.

WIRE IDENTIFICATION

All wires are identified by number and/or color. A tabular list of circuit designators and wire identification diagrams is included.

ABBREVIATIONS

All abbreviations are in accordance with ASME-Y14.38M, except where the abbreviation stands for a marking actually found in the CK.

WIRING DIAGRAMS

Wiring diagrams are included for all electrical systems and circuits.

**CONTAINERIZED KITCHEN (WITH TRAILER)
WIRING DIAGRAMS**

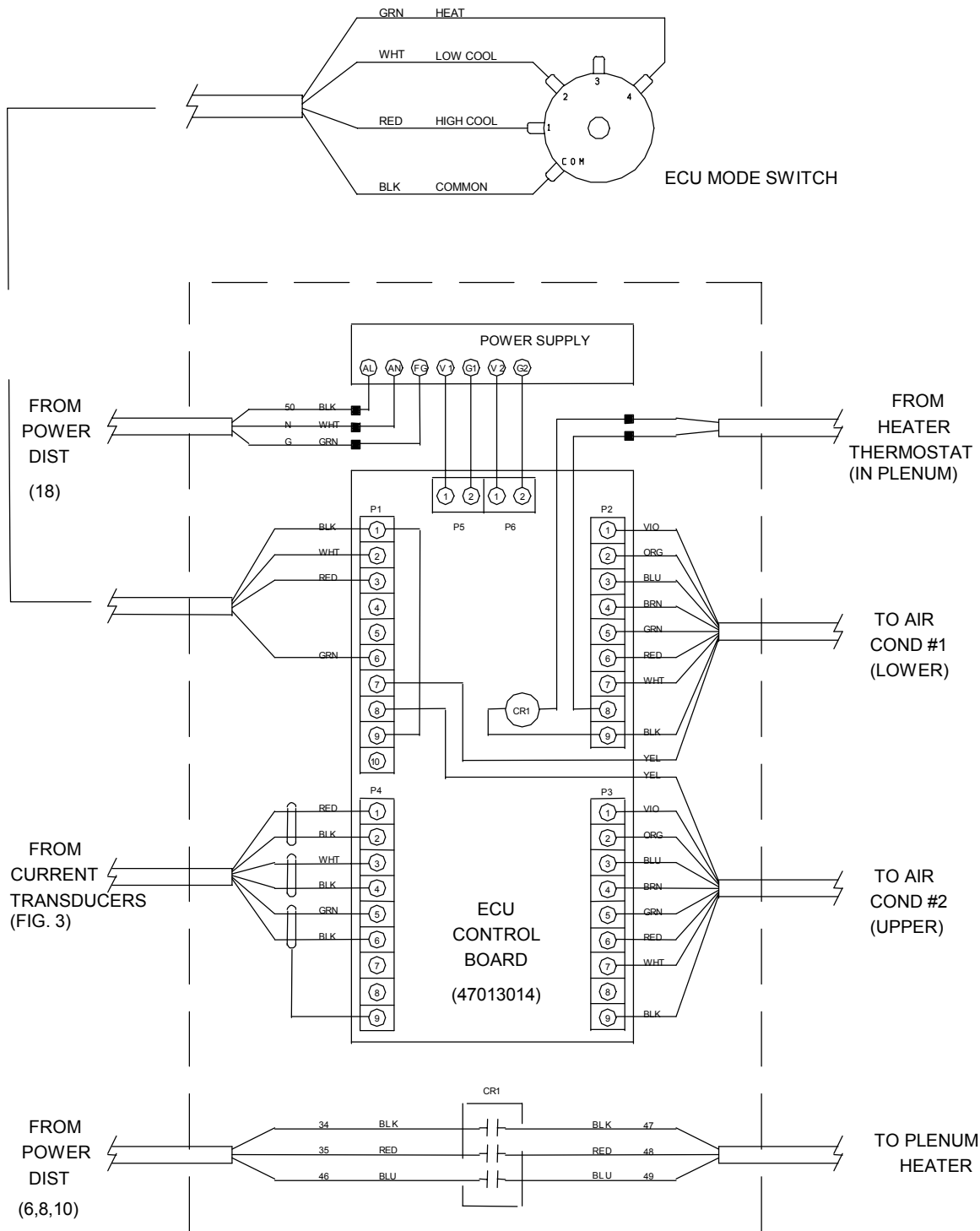

Figure 1. Wiring Diagram, ECU Controller.

**CONTAINERIZED KITCHEN (WITH TRAILER)
WIRING DIAGRAMS**

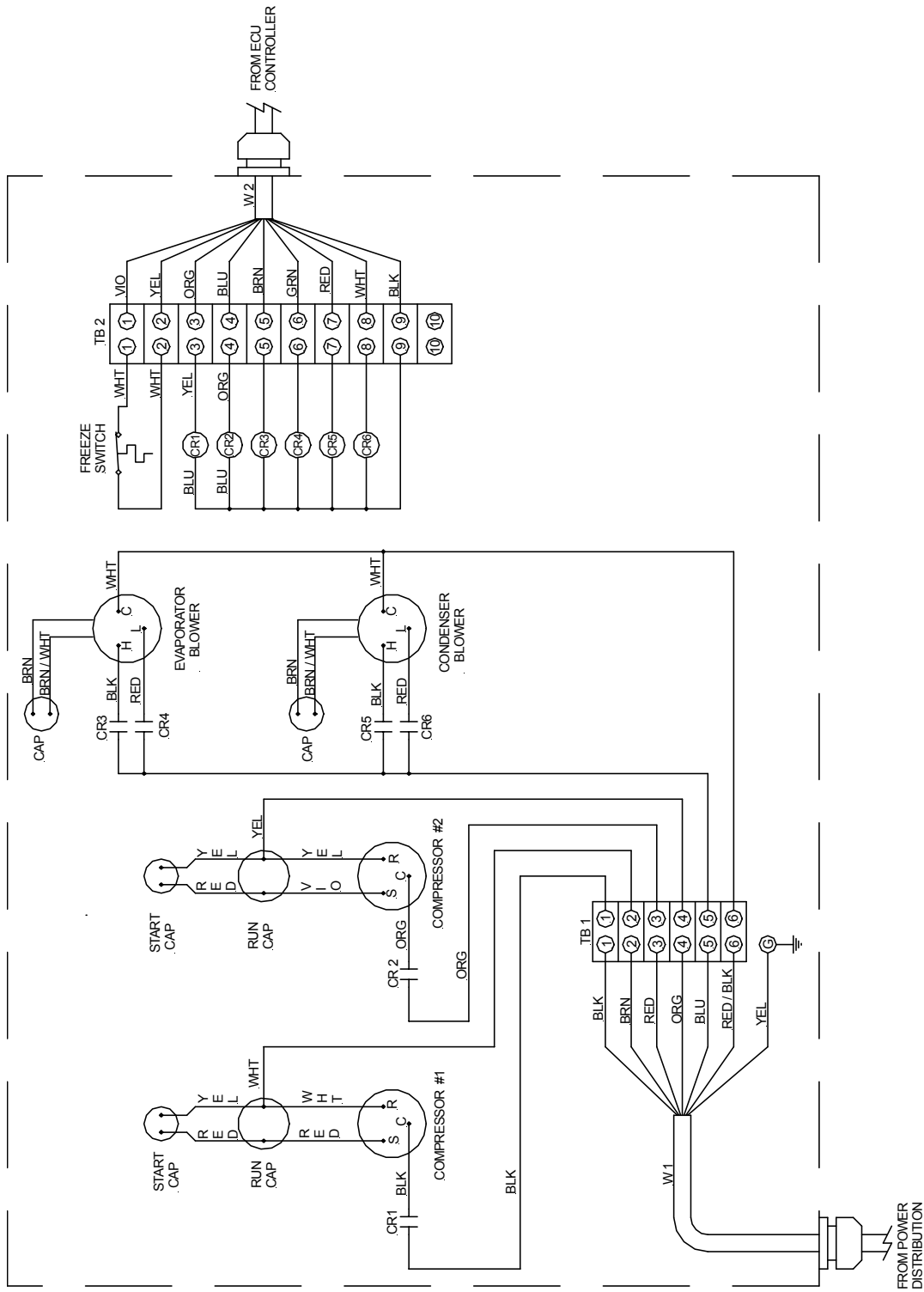

Figure 2. Wiring Diagram, ECU A/C Primary.

**CONTAINERIZED KITCHEN (WITH TRAILER)
WIRING DIAGRAMS**

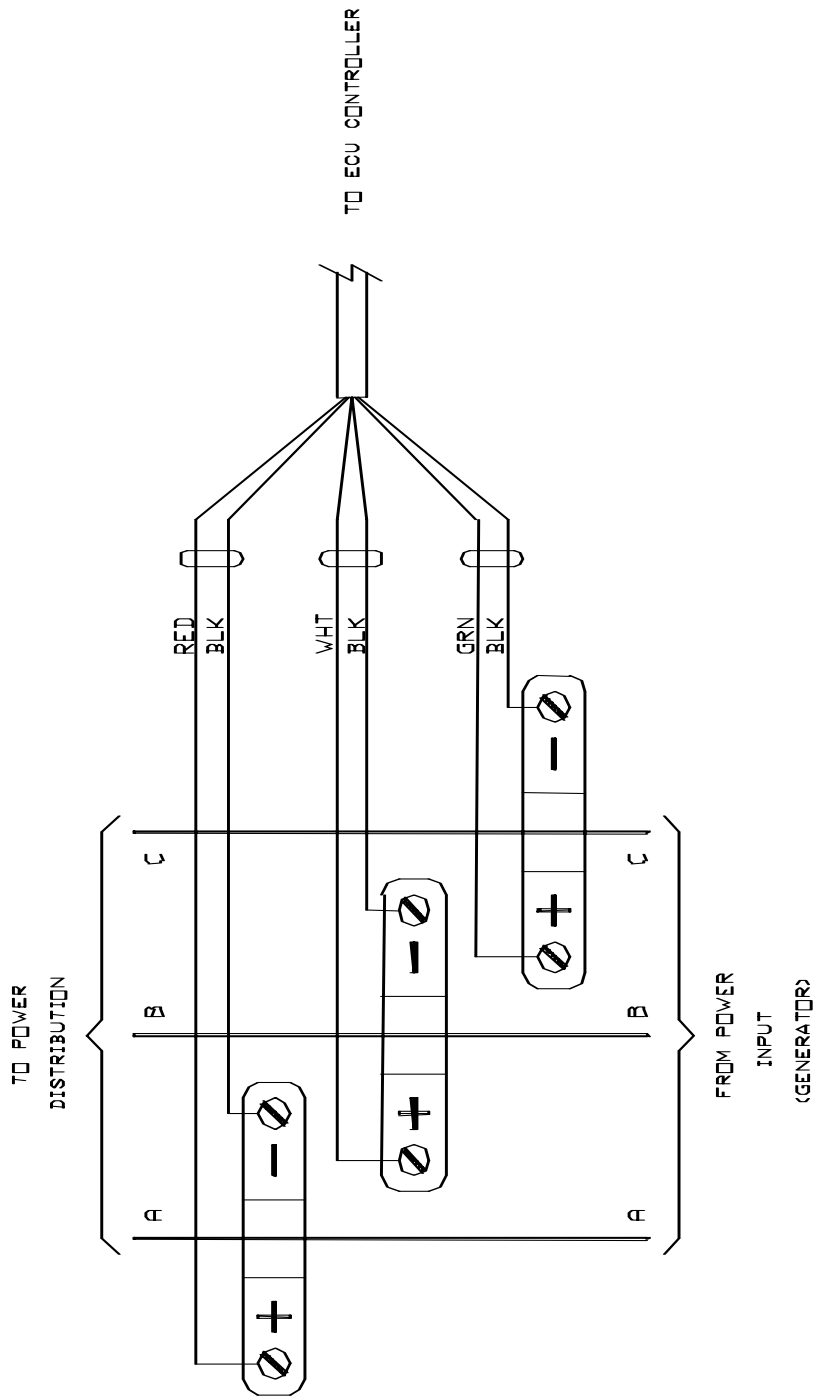

Figure 3. Wiring Diagram, Current Transducer.

**CONTAINERIZED KITCHEN (WITH TRAILER)
WIRING DIAGRAMS**

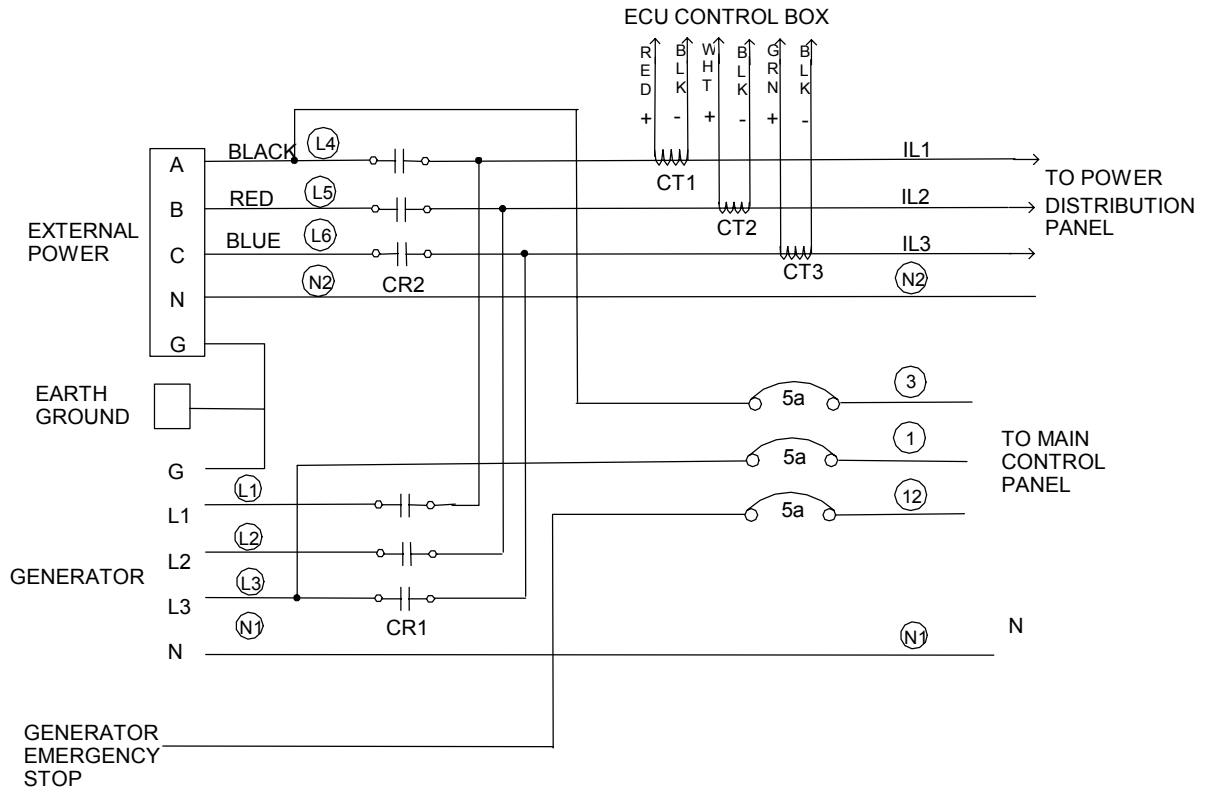

Figure 4. Wiring Diagram, Power Entrance Panel.

**CONTAINERIZED KITCHEN (WITH TRAILER)
WIRING DIAGRAMS**

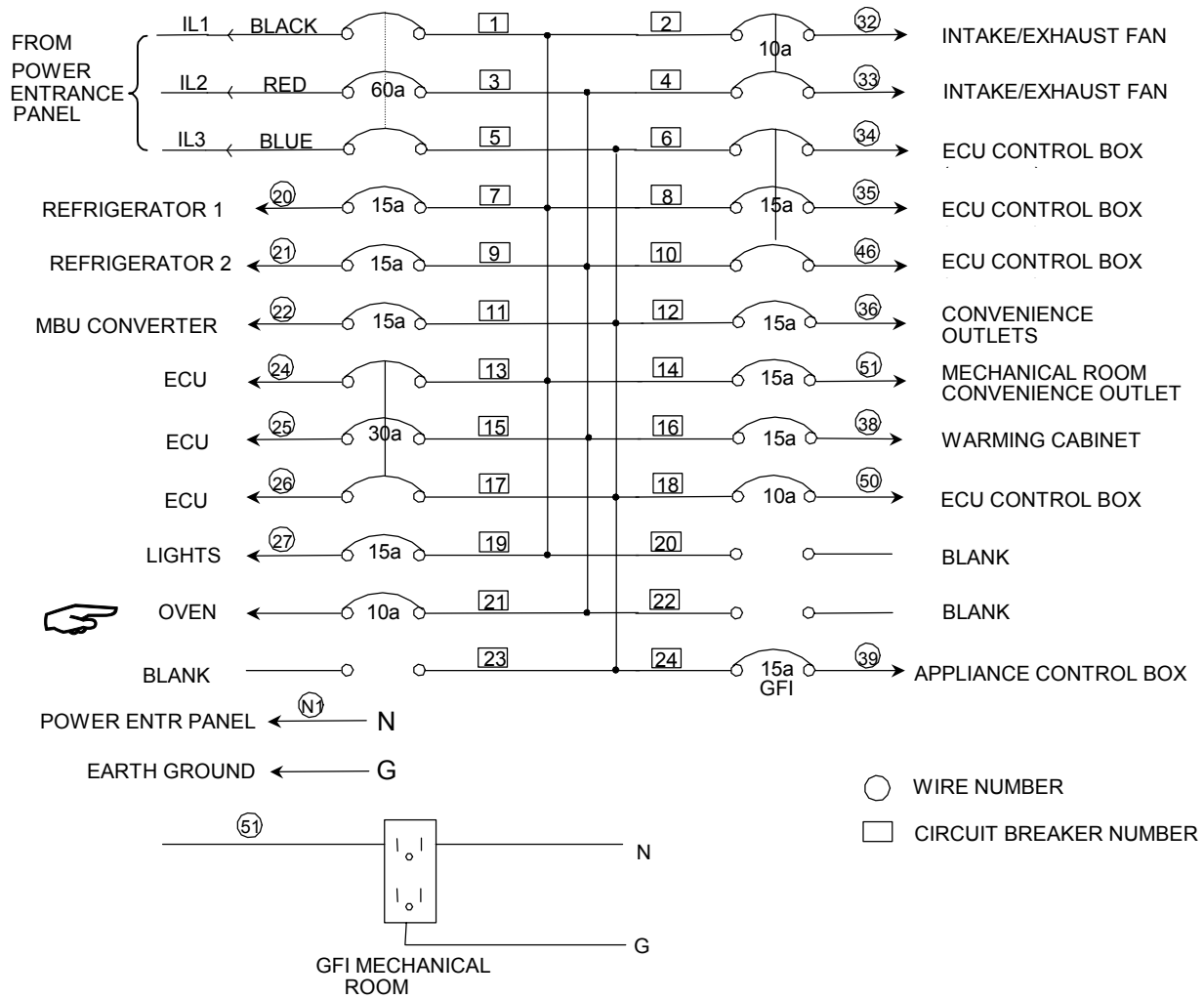

Figure 5. Wiring Diagram, Power Distribution Panel.

**CONTAINERIZED KITCHEN (WITH TRAILER)
WIRING DIAGRAMS**

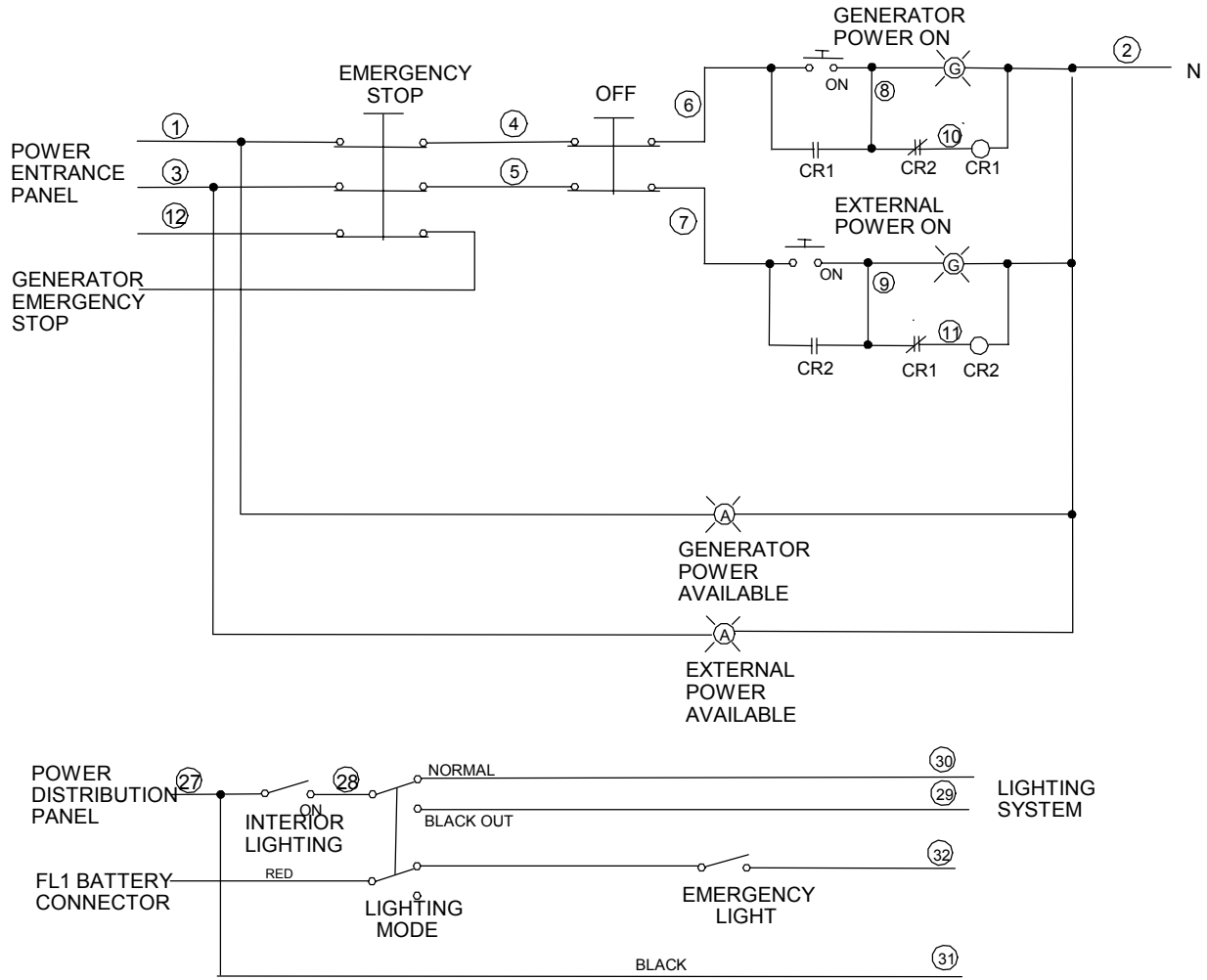

Figure 6. Wiring Diagram, Main Control Panel.

**CONTAINERIZED KITCHEN (WITH TRAILER)
WIRING DIAGRAMS**

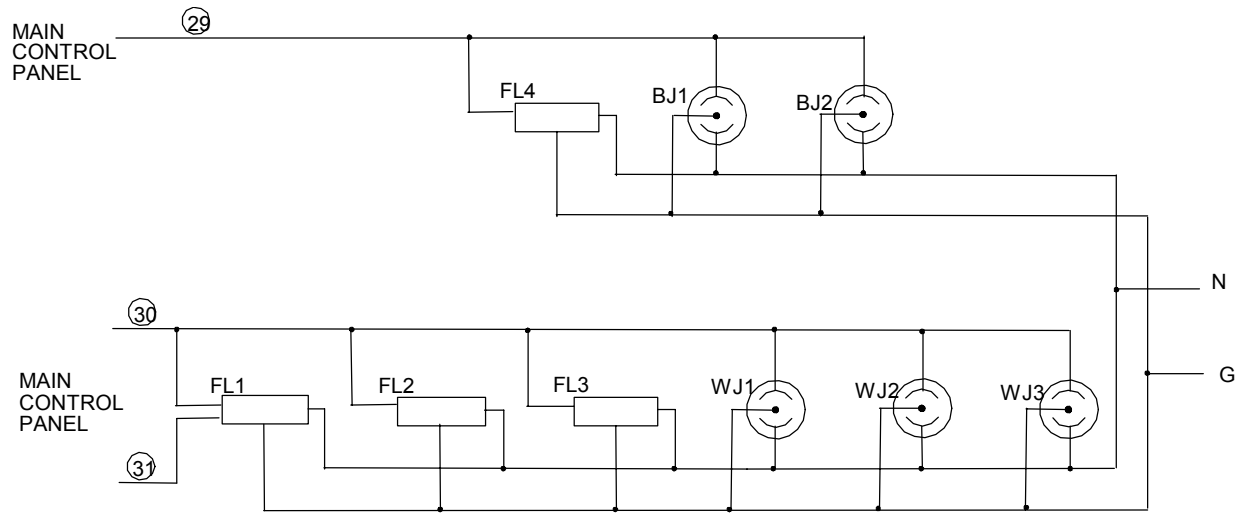

Figure 7. Wiring Diagram, Lighting System.

**CONTAINERIZED KITCHEN (WITH TRAILER)
WIRING DIAGRAMS**

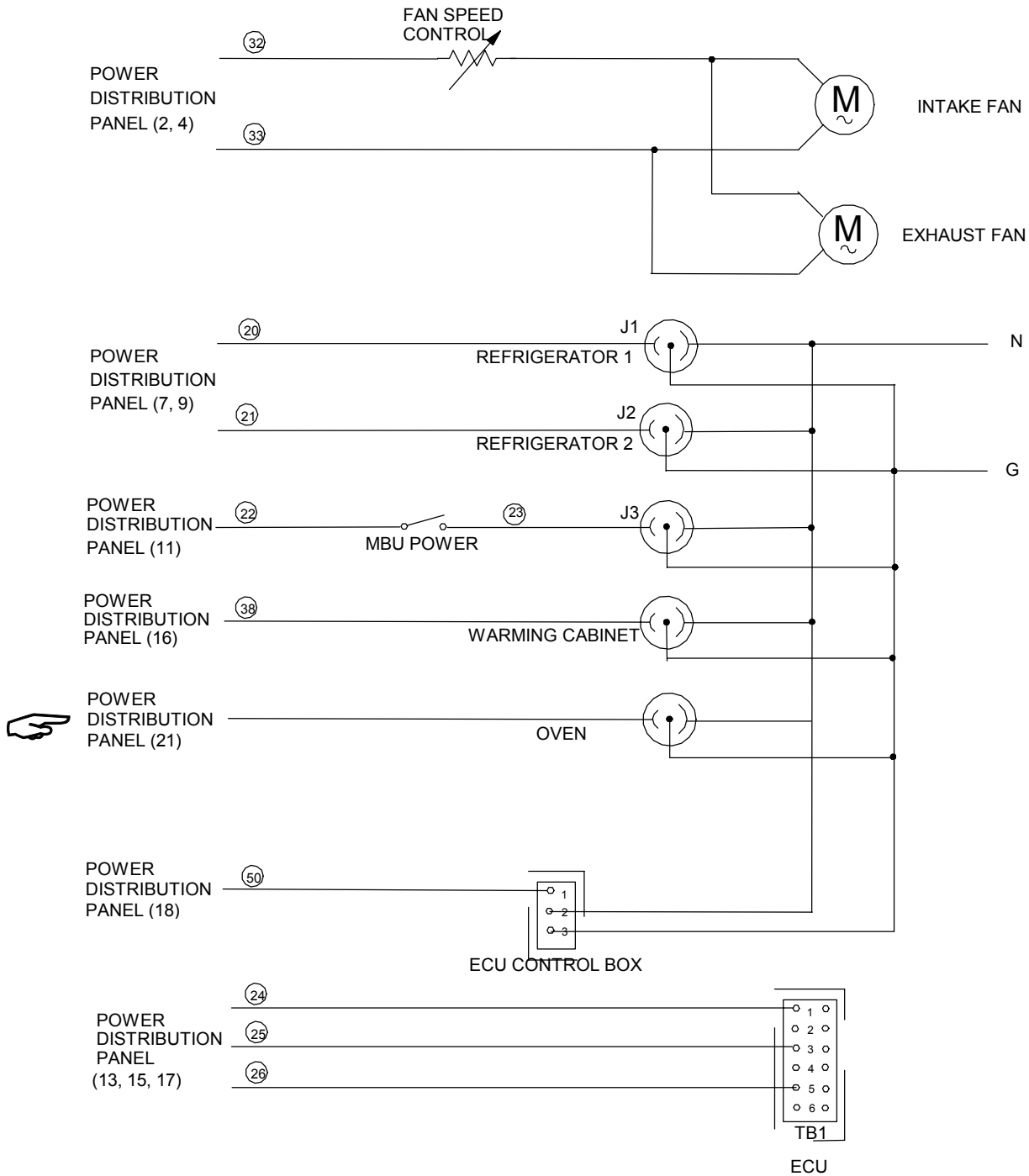
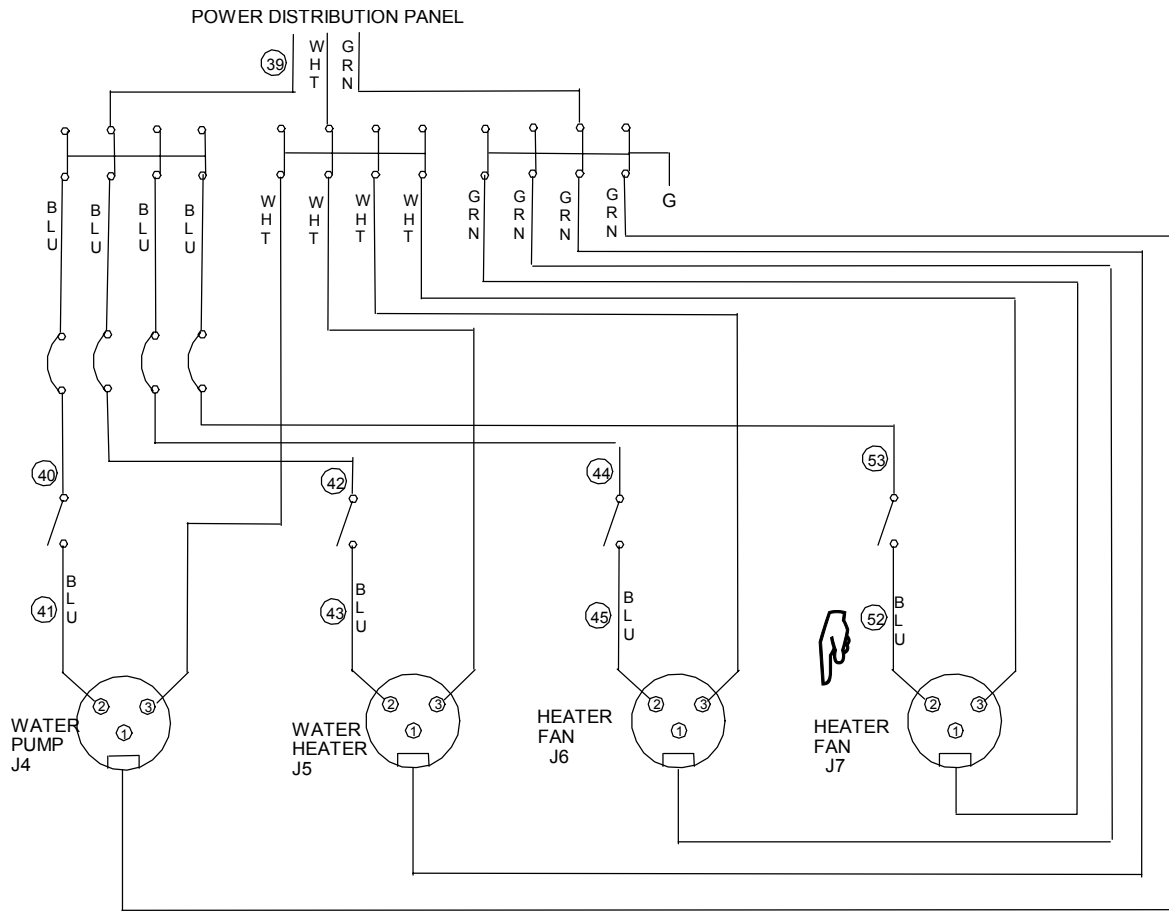

Figure 8. Wiring Diagram, Miscellaneous Circuits.

**CONTAINERIZED KITCHEN (WITH TRAILER)
WIRING DIAGRAMS**



■ Figure 9. Wiring Diagram, Appliance Control Box.

CONTAINERIZED KITCHEN (WITH TRAILER) TRAILER OPERATIONS

INTRODUCTION

The CK can be transported and deployed either mounted on, or separate from, its trailer (Chassis, Containerized Kitchen Trailer: 7½ Ton, 4-wheel XCK2000, NSN 2330-01-471-7006). The procedures for setting up, operating, and packing out the CK in either configuration are found in WP 0006 00. This work package provides instructions for mounting the CK on, and removing it from, the trailer. Refer to TM 9-2330-328-14&P for information about the trailer.

GENERAL INFORMATION

The CK container (Figure 1) is an 8-ft by 8-ft by 20-ft (2.44-m by 2.44-m by 6.1-m) International Organization for Standardization (ISO) container. The packed-out CK weighs approximately 14,080 lbs (6342 kg). It will normally be lifted using a Rough Terrain Container/Cargo Handler (RTCH) or a crane. Slots in the bottom edge of the container also allow it to be lifted using a fork lift with a capacity of at least 18,000 lbs (8172 kg). Since the container's center of gravity is not in the middle (the end with the double doors is heavier than the other end), only the outer pair of slots should be used to ensure stability when using a fork lift.

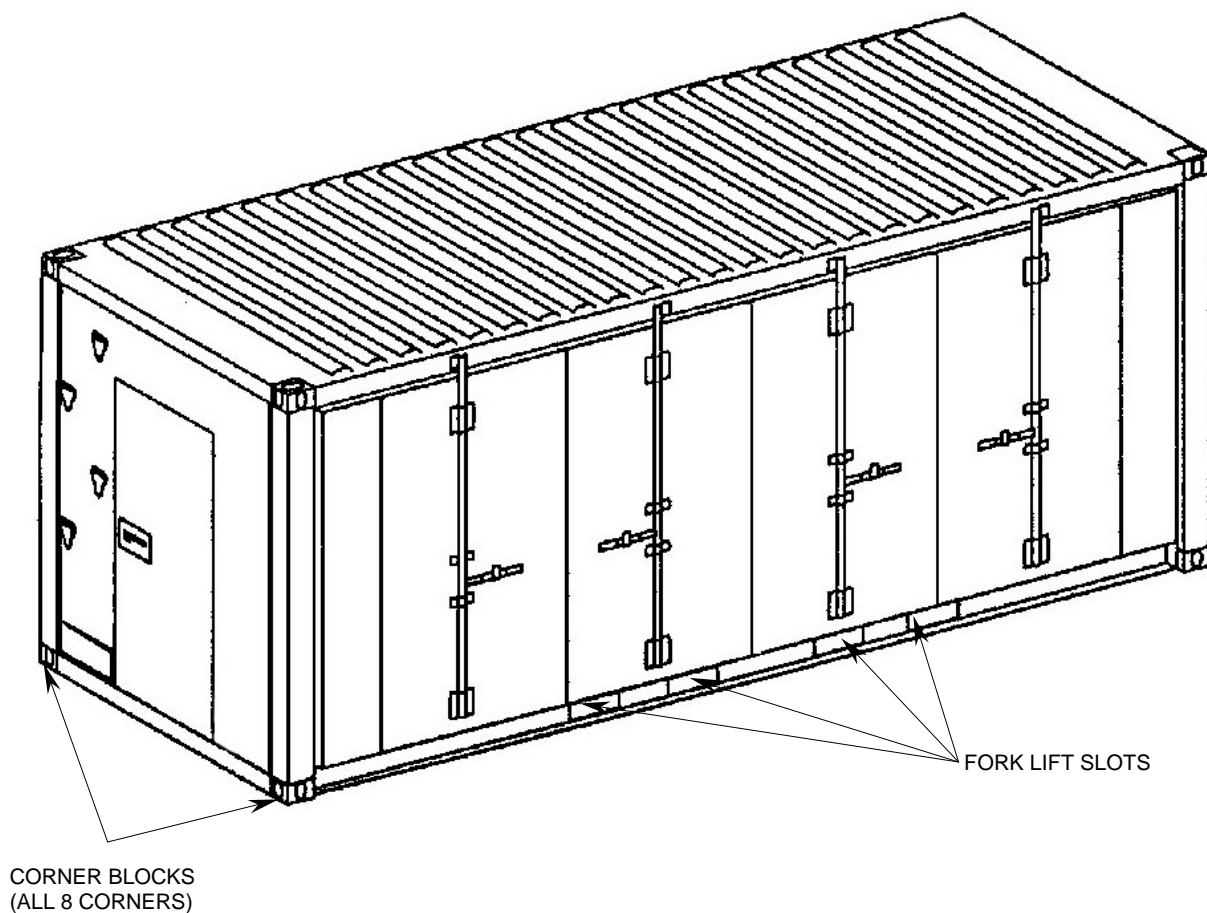

Figure 1. CK Container.

Corner blocks on each of the top corners provide attachment points for lifting the container with an RTCH or crane. Identical blocks on the bottom corners are engaged by ISO locks on the trailer (see Figure 2) to secure the container in place.

**CONTAINERIZED KITCHEN (WITH TRAILER)
TRAILER OPERATIONS**

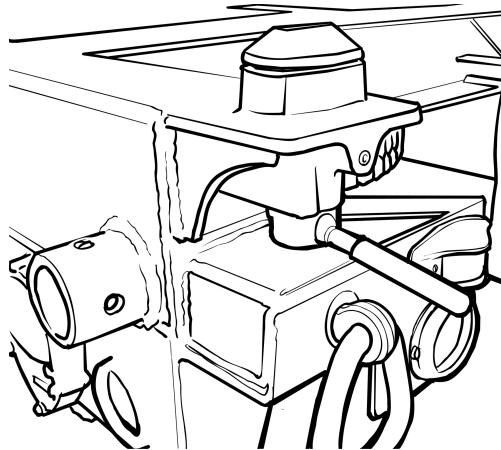

Figure 2. ISO Lock (shown unlocked).

MOUNTING THE CK ON THE TRAILER**CAUTION**

When shipping by standard flatbed trailer, the CK must be dismantled from its trailer and each should be shipped separately due to the combined height of the system. Under no circumstances shall the CK and its trailer be shipped on the same trailer.

1. Ensure that the four ISO locks on the corners of the trailer are unlocked (handles pointing outward from the sides of the trailer). See Figure 2.

WARNING

The CK weighs approximately 14,080 lbs (6342 kg). To avoid death or serious injury, all personnel must stand clear while the container is lifted and placed on the trailer.

CAUTION

To avoid exceeding the trailer's design tongue weight, position the CK so the end with single door is to the front of the trailer.

2. Lift the CK and place it on the trailer. See Figure 3. Ensure that the container rests flat on the trailer and the corner blocks are positioned over the ISO locks.
3. Engage the ISO locks by turning them 90 degrees in either direction.
4. If desired, level the trailer as described in WP 0006 00.

**CONTAINERIZED KITCHEN (WITH TRAILER)
TRAILER OPERATIONS**

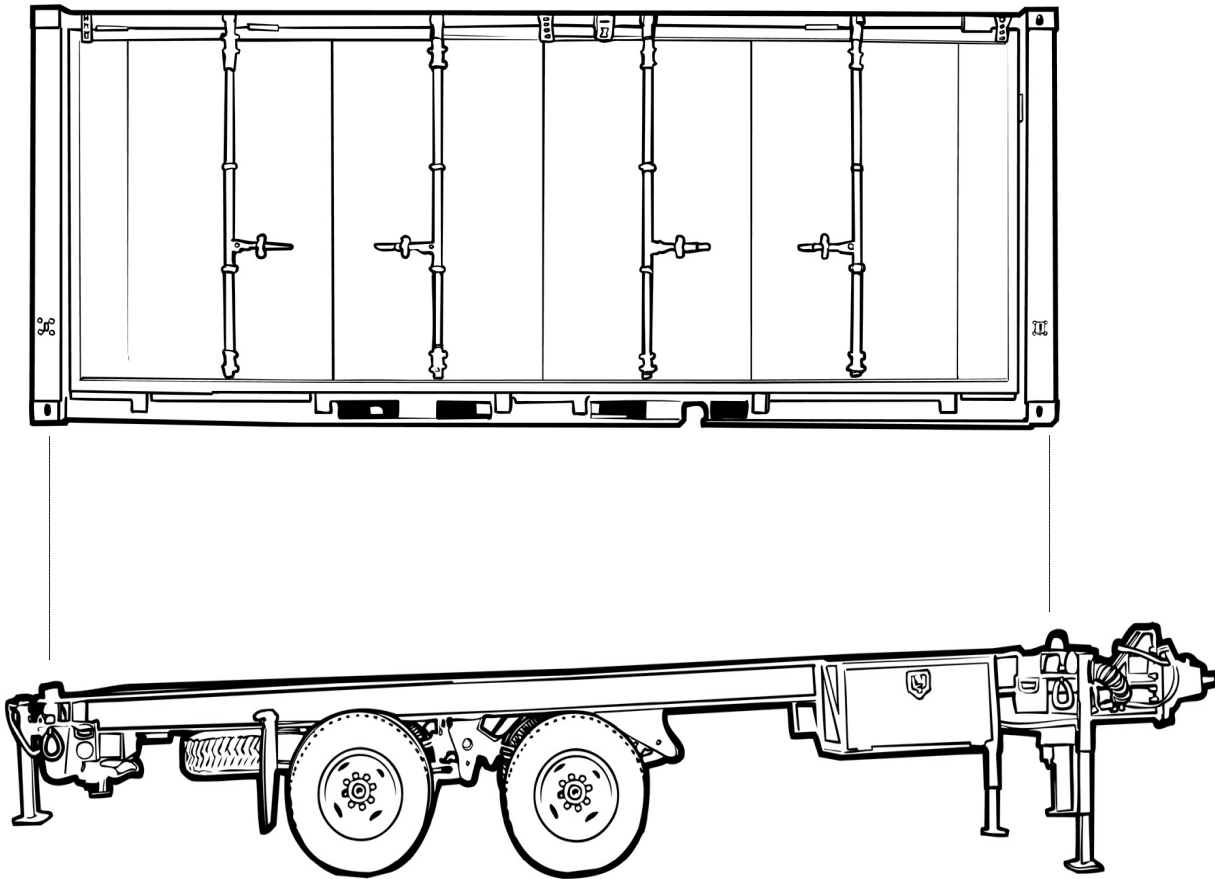

Figure 3. Mounting the CK on the Trailer.

REMOVING THE CK FROM THE TRAILER

1. Unlock the four ISO locks on the corners of the trailer by rotating the locking handles 90 degrees so the handles point outward from the sides of the trailer.

WARNING

The CK weighs approximately 14,080 lbs (6342 kg). To avoid death or serious injury, all personnel must stand clear while the container is lifted and removed from the trailer.

2. Lift the CK and remove it from the trailer using an RTCH, crane, or fork lift.

END OF WORK PACKAGE

**CONTAINERIZED KITCHEN (WITH TRAILER)
ALPHABETICAL INDEX**

<u>Subject</u>	<u>WP Sequence No. – Page No.</u>
A	
Abbreviations and Acronyms.....	0001 00-3
Additional Authorization List.....	0050 00-1
Adverse Weather Conditions.....	0007 00-1
After Operation PMCS	0016 00-9
Appliance and Equipment Relocation.....	0006 00-17
Assembly and Preparation for Use.....	0006 00-1
B	
Basic Issue Items (BII) List.....	0049 00-11
Before Operation PMCS	0016 00-3
Bulk Material Repair Parts List	0045 00-1
C	
Ceiling Light Installation	0006 00-21
Common Tools and Equipment.....	0004 00-1
Components of End Item (COEI) List.....	0049 00-2
Cook Center Repair Parts	0036 00-1
Corrosion Prevention and Control.....	0001 00-2
D	
Destruction of Army Materiel to Prevent Enemy Use.....	0001 00-2
Difference Between Models	0002 00-14
Direct Support Maintenance Procedures – Oven Assembly.....	0028 00-1
Direct Support Maintenance Procedures – Shelter Assembly/Mechanical Room.....	0030 00-1
Direct Support Maintenance Procedures – Cook Center	0027 00-1
Direct Support Maintenance Procedures – Tray Pack Heater ..	0029 00-1
During Operation PMCS	0016 00-7
E	
Electrical System Repair Parts.....	0044 00-1
Emergency Procedures.....	0007 00-4
Energizing the CK from External Power	0006 00-16
Energizing the CK from the Onboard Generator.....	0006 00-15
Equipment Characteristics, Capabilities and Features	0002 00-1
Equipment Data	0002 00-14
Equipment Improvement Recommendations.....	0001 00-2
Equipment Packout.....	0006 00-28
Expendable and Durable Items List.....	0051 00-1

**CONTAINERIZED KITCHEN (WITH TRAILER)
ALPHABETICAL INDEX**

<u>Subject</u>	<u>WP Sequence No. – Page No.</u>
F	
Fabric Erection – Food Preparation Wing.....	0006 00-11
Fabric Erection – Serving Wing.....	0006 00-7
Food Preparation Wing Closure.....	0006 00-32
Fording and Swimming.....	0007 00-3
G	
General Information.....	0001 00-1
Grounding.....	0006 00-14
H	
Hand Sink Assembly Repair Parts.....	0041 00-1
I	
Interim NBC Decontamination Procedures.....	0007 00-3
J	
Jamming and Electronic Countermeasures.....	0007 00-3
K	
Kitchen Operation.....	0006 00-23
L	
Leveling the Container on the Ground.....	0006 00-2
Leveling the Container on the Trailer.....	0006 00-5
Location and Description of Major Components.....	0002 00-3
Loose Item Packout List.....	0006 00-27
M	
Maintenance Allocation Chart (MAC).....	0032 00-5
Maintenance Forms, Records and Reports.....	0001 00-2
Malfunction/Symptom Index.....	0009 00-1
Mandatory Replacement Parts.....	0053 00-1
Mechanical Room Packout.....	0006 00-34
Mechanical Room Repair Parts.....	0035 00-1
Mechanical Room Setup.....	0006 00-12
Mobile Storage Cabinet Repair Parts.....	0042 00-1
Mobile Warming Cabinet Repair Parts.....	0038 00-1
N	
National Stock Number Index.....	0047 00-1
Nomenclature Cross-Reference List.....	0001 00-3
Nuclear Hardness.....	0001 00-4

**CONTAINERIZED KITCHEN (WITH TRAILER)
ALPHABETICAL INDEX**

<u>Subject</u>	<u>WP Sequence No. – Page No.</u>
O	
Operation Under Unusual Conditions	0007 00-1
Operation Under Usual Conditions	0006 00-1
Operator Controls and Indicators	0005 00-1
Appliance Control Box	0005 00-7
Cook Center Ventilation	0005 00-8
Environmental Control Unit (ECU)	0005 00-10
Main Control Panel	0005 00-3
MBU Control Panel	0005 00-6
MBU Converter	0005 00-5
MBU Power Switch	0005 00-4
Mobile Warming Cabinet	0005 00-9
Oven	0005 00-10
Power Distribution Panel	0005 00-2
Power Entrance Panel	0005 00-1
Refrigerators	0005 00-9
Oven Assembly Repair Parts	0037 00-1
P	
Packout and Preparation for Transport	0006 00-24
Pan Rack	0006 00-19
Part Number Index	0048 00-1
Platform Installation	0006 00-14
PMCS – Introduction	0016 00-1
Prep/Serving Table Repair Parts	0043 00-1
Preparation for Packout	0006 00-25
Preparation for Storage and Shipment	0001 00-2
R	
References	0031 00-1
Refrigerator Repair Parts	0039 00-1
Repair Parts	0004 00-1
Repair Parts & Special Tools List	0033 00-1
S	
Scope of Manual	0001 00-1
Service Upon Receipt	0015 00-1
Serving Wing Closure	0006 00-33
Shelter Deployment	0006 00-2
Shelter Expansion	0006 00-5
Shelter Repair Parts	0034 00-1
Site Requirements	0006 00-1
Special Tools List	0045 00-1
Special Tools, TMDE, and Support Equipment	0004 00-1

**CONTAINERIZED KITCHEN (WITH TRAILER)
ALPHABETICAL INDEX**

<u>Subject</u>	<u>WP Sequence No. – Page No.</u>
T	
Theory of Operation	0003 00-1
Tool Identification List	0052 00-1
Tools and Test Equipment	0032 00-9
Trailer Operations	0055 00-1
Tray Pack Heater Repair Parts	0040 00-1
Troubleshooting Procedures – Electrical	0010 00-1
Troubleshooting Procedures – Environmental Control	0012 00-1
Troubleshooting Procedures – Hand Sink Assembly.....	0013 00-1
Troubleshooting Procedures – Kitchen Appliances	0014 00-1
Troubleshooting Procedures – MBU	0011 00-1
U	
Unit Maintenance Procedures – Cook Center	0019 00-1
Unit Maintenance Procedures – Oven Assembly	0020-00-1
Unit Maintenance Procedures – Electrical System	0026 00-1
Unit Maintenance Procedures – Environmental Control	0025 00-1
Unit Maintenance Procedures – Hand Sink Assembly.....	0024 00-1
Unit Maintenance Procedures – Mechanical Room.....	0018 00-1
Unit Maintenance Procedures – Mobile Storage Cabinets	0025 00-1
Unit Maintenance Procedures – Mobile Warming Cabinet	0021 00-1
Unit Maintenance Procedures – Refrigerators.....	0022 00-1
Unit Maintenance Procedures – Shelter Assembly.....	0017 00-1
Unit Maintenance Procedures – Tray Pack Heater.....	0023 00-1
Unpacking the Mechanical Room.....	0006 00-2
W	
Warranty Information.....	0001 00-2
Water and Drain System Startup.....	0006 00-22
Winch Assembly and Cable	0017 00-1
Winch Cable Removal/Replacement.....	0017 00-2
Wiring Diagrams	0054 00-1

By Order of the Secretary of the Army:

Official:



JOEL B. HUDSON

*Administrative Assistant to the
Secretary of the Army*

0120003

ERIC K. SHINSEKI
*General, United States Army
Chief of Staff*

DISTRIBUTION:

To be distributed in accordance with initial distribution IDN 256683, requirements for
TM 10-7360-226-13&P.

These are the instructions for sending an electronic 2028

The following format must be used if submitting an electronic 2028. The subject line must be exactly the same and all fields must be included; however only the following fields are mandatory: 1, 3, 4, 5, 6, 7, 8, 9, 10, 13, 15, 16, 17, and 27.

From: "Whomever" <whomever@avma27.army.mil>
To: amssbriml@natick.army.mil

Subject: DA Form 2028

1. From: Joe Smith
2. Unit: home
3. Address: 4300 Park
4. City: Hometown
5. St: MO
6. Zip: 77777
7. Date Sent: 19-OCT-93
8. Pub no: 55-2840-229-23
9. Pub Title: TM
10. Publication Date: 04-JUL-85
11. Change Number: 7
12. Submitter Rank: MSG
13. Submitter FName: Joe
14. Submitter MName: T
15. Submitter LName: Smith
16. Submitter Phone: 123-123-1234
17. Problem: 1
18. Page: 2
19. Paragraph: 3
20. Line: 4
21. NSN: 5
22. Reference: 6
23. Figure: 7
24. Table: 8
25. Item: 9
26. Total: 123
27. Text:

This is the text for the problem below line 27.

RECOMMENDED CHANGES TO PUBLICATIONS AND BLANK FORMS For use of this form, see AR 25-30; the proponent agency is ODISC4.						Use Part II (reverse) for Repair Parts and Special Tool Lists (RPSTL) and Supply Catalogs/Supply Manuals (SC/SM).	DATE 21 October 2003
TO: (Forward to proponent of publication or form) (Include ZIP Code) COMMANDER U.S. ARMY TANK-AUTOMOTIVE AND ARMAMENT COMMAND ATTN: AMSTA-LC-CECT 15 KANSAS STREET NATICK, MA 01760-5052						FROM: (Activity and location) (Include ZIP Code) <i>PFC Jane Doe</i> <i>CO A 3rd Engineer BR</i> <i>Ft. Leonardwood, MO 63108</i>	
PART I – ALL PUBLICATIONS (EXCEPT RPSTL AND SC/SM) AND BLANK FORMS							
PUBLICATION/FORM NUMBER TM 10-1670-296-23&P				DATE 30 October 2002	TITLE Unit Manual for Ancillary Equipment for Low Velocity Air Drop Systems		
ITEM NO.	PAGE NO.	PARA-GRAPH	LINE NO. *	FIGURE NO.	TABLE NO.	RECOMMENDED CHANGES AND REASON <i>(Provide exact wording of recommended changes, if possible).</i>	
	0036 00-2				1	<i>In table 1, Sewing Machine Code Symbols, the second sewing machine code symbol should be MD ZZ not MD 22.</i> <i>Change the manual to show Sewing Machine, Industrial: Zig-Zag; 308 stitch; medium-duty; NSN 3530-01-181-1421 as a MD ZZ code symbol.</i>	
<small>*Reference to line numbers within the paragraph or subparagraph.</small>							
TYPED NAME, GRADE OR TITLE Jane Doe, PFC				TELEPHONE EXCHANGE/AUTOVON, PLUS EXTENSION 508-233-4141		SIGNATURE <i>Jane Doe</i>	

TO: (Forward direct to addressee listed in publication) COMMANDER U.S. ARMY TANK-AUTOMOTIVE AND ARMAMENT COMMAND ATTN: AMSTA-LC-CECT 15 KANSAS STREET NATICK, MA 01760-5052	FROM: (Activity and location) (Include ZIP Code) <i>PFC Jane Doe</i> <i>CO A 3rd Engineer BR</i> <i>Ft. Leonardwood, MO 63108</i>	DATE 21 October 2003
---	--	--------------------------------

PART II – REPAIR PARTS AND SPECIAL TOOL LISTS AND SUPPLY CATALOGS/SUPPLY MANUALS

PUBLICATION NUMBER TM 10-1670-296-23&P	DATE 30 October 2002	TITLE Unit Manual for Ancillary Equipment for Low Velocity Air Drop Systems
--	--------------------------------	---

PAGE NO.	COLM NO.	LINE NO.	NATIONAL STOCK NUMBER	REFERENCE NO.	FIGURE NO.	ITEM NO.	TOTAL NO. OF MAJOR ITEMS SUPPORTED	RECOMMENDED ACTION
0066 00-1					4			<i>Callout 16 in figure 4 is pointed to a <u>D-Ring</u>. In the Repair Parts List key for figure 4, item 16 is called a <u>Snap Hook</u>. Please correct one or the other.</i>

PART III – REMARKS (Any general remarks or recommendations, or suggestions for improvement of publications and blank forms. Additional blank sheets may be used if more space is needed.)

--	--	--

TYPED NAME, GRADE OR TITLE	TELEPHONE EXCHANGE/AUTOVON, PLUS EXTENSION	SIGNATURE
----------------------------	--	-----------

RECOMMENDED CHANGES TO PUBLICATIONS AND BLANK FORMS						Use Part II (reverse) for Repair Parts and Special Tool Lists (RPSTL) and Supply Catalogs/Supply Manuals (SC/SM).	DATE
For use of this form, see AR 25-30; the proponent agency is ODISC4.							
TO: (Forward to proponent of publication or form) (Include ZIP Code) Commander U.S. Army Tank-automotive and Armament Command ATTN: AMSTA-LC-CECT Kansas Street, Natick, MA 01760-5052.						FROM: (Activity and location) (Include ZIP Code)	
PART I – ALL PUBLICATIONS (EXCEPT RPSTL AND SC/SM) AND BLANK FORMS							
PUBLICATION/FORM NUMBER TM 10-7360-226-13&P				DATE 1 Aug 2001		TITLE Operator's, Unit and Direct Support Maintenance Manual (including Repair Parts and Special Tools List) for Containerized Kitchen (w/ Trailer)	
ITEM NO.	PAGE NO.	PARA-GRAPH	LINE NO. *	FIGURE NO.	TABLE NO.	RECOMMENDED CHANGES AND REASON (Provide exact wording of recommended changes, if possible).	
<i>*Reference to line numbers within the paragraph or subparagraph.</i>							
TYPED NAME, GRADE OR TITLE				TELEPHONE EXCHANGE/AUTOVON, PLUS EXTENSION		SIGNATURE	

TO: <i>(Forward direct to addressee listed in publication)</i> Commander U.S. Army Tank-automotive and Armament Command ATTN: AMSTA-LC-CECT Kansas Street, Natick, MA 01760-5052.	FROM: <i>(Activity and location) (Include ZIP Code)</i>	DATE
--	--	-------------

PART II – REPAIR PARTS AND SPECIAL TOOL LISTS AND SUPPLY CATALOGS/SUPPLY MANUALS

PUBLICATION NUMBER TM 10-7360-226-13&P	DATE 1 Aug 2001	TITLE Operator's, Unit and Direct Support Maintenance Manual (including Repair Parts and Special Tools List) for Containerized Kitchen (w/ Trailer)
---	--------------------	--

PAGE NO.	COLM NO.	LINE NO.	NATIONAL STOCK NUMBER	REFERENCE NO.	FIGURE NO.	ITEM NO.	TOTAL NO. OF MAJOR ITEMS SUPPORTED	RECOMMENDED ACTION

PART III – REMARKS *(Any general remarks or recommendations, or suggestions for improvement of publications and blank forms. Additional blank sheets may be used if more space is needed.)*

TYPED NAME, GRADE OR TITLE	TELEPHONE EXCHANGE/AUTOVON, PLUS EXTENSION	SIGNATURE
----------------------------	--	-----------

RECOMMENDED CHANGES TO PUBLICATIONS AND BLANK FORMS						Use Part II (reverse) for Repair Parts and Special Tool Lists (RPSTL) and Supply Catalogs/Supply Manuals (SC/SM).	DATE
For use of this form, see AR 25-30; the proponent agency is ODISC4.							
TO: (Forward to proponent of publication or form) (Include ZIP Code) Commander U.S. Army Tank-automotive and Armament Command ATTN: AMSTA-LC-CECT Kansas Street, Natick, MA 01760-5052.						FROM: (Activity and location) (Include ZIP Code)	
PART I – ALL PUBLICATIONS (EXCEPT RPSTL AND SC/SM) AND BLANK FORMS							
PUBLICATION/FORM NUMBER TM 10-7360-226-13&P				DATE 1 Aug 2001		TITLE Operator's, Unit and Direct Support Maintenance Manual (including Repair Parts and Special Tools List) for Containerized Kitchen (w/ Trailer)	
ITEM NO.	PAGE NO.	PARA-GRAPH	LINE NO. *	FIGURE NO.	TABLE NO.	RECOMMENDED CHANGES AND REASON (Provide exact wording of recommended changes, if possible).	
<i>*Reference to line numbers within the paragraph or subparagraph.</i>							
TYPED NAME, GRADE OR TITLE				TELEPHONE EXCHANGE/AUTOVON, PLUS EXTENSION		SIGNATURE	

TO: <i>(Forward direct to addressee listed in publication)</i> Commander U.S. Army Tank-automotive and Armament Command ATTN: AMSTA-LC-CECT Kansas Street, Natick, MA 01760-5052.	FROM: <i>(Activity and location) (Include ZIP Code)</i>	DATE
--	--	-------------

PART II – REPAIR PARTS AND SPECIAL TOOL LISTS AND SUPPLY CATALOGS/SUPPLY MANUALS

PUBLICATION NUMBER TM 10-7360-226-13&P	DATE 1 Aug 2001	TITLE Operator's, Unit and Direct Support Maintenance Manual (including Repair Parts and Special Tools List) for Containerized Kitchen (w/ Trailer)
---	--------------------	--

PAGE NO.	COLM NO.	LINE NO.	NATIONAL STOCK NUMBER	REFERENCE NO.	FIGURE NO.	ITEM NO.	TOTAL NO. OF MAJOR ITEMS SUPPORTED	RECOMMENDED ACTION

PART III – REMARKS *(Any general remarks or recommendations, or suggestions for improvement of publications and blank forms. Additional blank sheets may be used if more space is needed.)*

TYPED NAME, GRADE OR TITLE	TELEPHONE EXCHANGE/AUTOVON, PLUS EXTENSION	SIGNATURE
----------------------------	--	-----------

RECOMMENDED CHANGES TO PUBLICATIONS AND BLANK FORMS						Use Part II (reverse) for Repair Parts and Special Tool Lists (RPSTL) and Supply Catalogs/Supply Manuals (SC/SM).	DATE
For use of this form, see AR 25-30; the proponent agency is ODISC4.							
TO: (Forward to proponent of publication or form) (Include ZIP Code) Commander U.S. Army Tank-automotive and Armament Command ATTN: AMSTA-LC-CECT Kansas Street, Natick, MA 01760-5052.						FROM: (Activity and location) (Include ZIP Code)	
PART I – ALL PUBLICATIONS (EXCEPT RPSTL AND SC/SM) AND BLANK FORMS							
PUBLICATION/FORM NUMBER TM 10-7360-226-13&P				DATE 1 Aug 2001		TITLE Operator's, Unit and Direct Support Maintenance Manual (including Repair Parts and Special Tools List) for Containerized Kitchen (w/ Trailer)	
ITEM NO.	PAGE NO.	PARA-GRAPH	LINE NO. *	FIGURE NO.	TABLE NO.	RECOMMENDED CHANGES AND REASON <i>(Provide exact wording of recommended changes, if possible).</i>	
*Reference to line numbers within the paragraph or subparagraph.							
TYPED NAME, GRADE OR TITLE				TELEPHONE EXCHANGE/AUTOVON, PLUS EXTENSION		SIGNATURE	

TO: <i>(Forward direct to addressee listed in publication)</i> Commander U.S. Army Tank-automotive and Armament Command ATTN: AMSTA-LC-CECT Kansas Street, Natick, MA 01760-5052.	FROM: <i>(Activity and location) (Include ZIP Code)</i>	DATE
--	--	-------------

PART II – REPAIR PARTS AND SPECIAL TOOL LISTS AND SUPPLY CATALOGS/SUPPLY MANUALS

PUBLICATION NUMBER TM 10-7360-226-13&P	DATE 1 Aug 2001	TITLE Operator's, Unit and Direct Support Maintenance Manual (including Repair Parts and Special Tools List) for Containerized Kitchen (w/ Trailer)
---	--------------------	--

PAGE NO.	COLM NO.	LINE NO.	NATIONAL STOCK NUMBER	REFERENCE NO.	FIGURE NO.	ITEM NO.	TOTAL NO. OF MAJOR ITEMS SUPPORTED	RECOMMENDED ACTION

PART III – REMARKS *(Any general remarks or recommendations, or suggestions for improvement of publications and blank forms. Additional blank sheets may be used if more space is needed.)*

--

TYPED NAME, GRADE OR TITLE	TELEPHONE EXCHANGE/AUTOVON, PLUS EXTENSION	SIGNATURE
----------------------------	--	-----------

The Metric System and Equivalents

Linear Measure

1 centimeter = 10 millimeters = .39 inch
 1 decimeter = 10 centimeters = 3.94 inches
 1 meter = 10 decimeters = 39.37 inches
 1 dekameter = 10 meters = 32.8 feet
 1 hectometer = 10 dekameters = 328.08 feet
 1 kilometer = 10 hectometers = 3,280.8 feet

Weights

1 centigram = 10 milligrams = .15 grain
 1 decigram = 10 centigrams = 1.54 grains
 1 gram = 10 decigrams = .035 ounce
 1 dekagram = 10 grams = .35 ounce
 1 hectogram = 10 dekagrams = 3.52 ounces
 1 kilogram = 10 hectograms = 2.2 pounds
 1 quintal = 100 kilograms = 220.46 pounds
 1 metric ton = 10 quintals = 1.1 short tons

Liquid Measure

1 centiliter = 10 milliliters = .34 fl. ounce
 1 deciliter = 10 centiliters = 3.38 fl. ounces
 1 liter = 10 deciliters = 33.81 fl. ounces
 1 dekaliter = 10 liters = 2.64 gallons
 1 hectoliter = 10 dekaliters = 26.42 gallons
 1 kiloliter = 10 hectoliters = 264.18 gallons

Square Measure

1 sq. centimeter = 100 sq. millimeters = .155 sq. inch
 1 sq. decimeter = 100 sq. centimeters = 15.5 sq. inches
 1 sq. meter (centare) = 100 sq. decimeters = 10.76 sq. feet
 1 sq. dekameter (are) = 100 sq. meters = 1,076.4 sq. feet
 1 sq. hectometer (hectare) = 100 sq. dekameters = 2.47 acres
 1 sq. kilometer = 100 sq. hectometers = .386 sq. mile

Cubic Measure

1 cu. centimeter = 1000 cu. millimeters = .06 cu. inch
 1 cu. decimeter = 1000 cu. centimeters = 61.02 cu. inches
 1 cu. meter = 1000 cu. decimeters = 35.31 feet

Approximate Conversion Factors

<i>To change</i>	<i>To</i>	<i>Multiply by</i>	<i>To change</i>	<i>To</i>	<i>Multiply by</i>
inches	centimeters	2.540	ounce-inches	newton-meters	.007062
feet	meters	.305	centimeters	inches	.394
yards	meters	.914	meters	feet	3.280
miles	kilometers	1.609	meters	yards	1.094
square inches	square centimeters	6.451	kilometers	miles	.621
square feet	square meters	.093	square centimeters	square inches	.155
square yards	square meters	.836	square meters	square feet	10.764
square miles	square kilometers	2.590	square meters	square yards	1.196
acres	square hectometers	.405	square kilometers	square miles	.386
cubic feet	cubic meters	.028	square hectometers	acres	2.471
cubic yards	cubic meters	.765	cubic meters	cubic feet	35.315
fluid ounces	milliliters	29.573	cubic meters	cubic yards	1.308
pints	liters	.473	milliliters	fluid ounces	.034
quarts	liters	.946	liters	pints	2.113
gallons	liters	3.785	liters	quarts	1.057
ounces	grams	28.349	liters	gallons	.264
pounds	kilograms	.454	grams	ounces	.035
short tons	metric tons	.907	kilograms	pounds	2.205
pound-feet	newton-meters	1.356	metric tons	short tons	1.102
pound-inches	newton-meters	.11296			

Temperature (Exact)

_F	Fahrenheit temperature	5/9 (after subtracting 32)	Celsius temperature	_C
----	---------------------------	-------------------------------	------------------------	----

PIN: 079150-000